

BODY ELECTRICAL SYSTEM

BE09Y-01

PRECAUTION

Take care to observe the following precautions when performing inspections or removal and replacement of body electrical related parts.

1. HEADLIGHT SYSTEM

- Halogen bulbs have pressurized gas inside and require special handling. They can burst if scratched or dropped. Hold a bulb only by its plastic or metal case. Don't touch the glass part of a bulb with bare hands.

2. SRS (SUPPLEMENTAL RESTRAINT SYSTEM)

- The CAMRY is equipped with an SRS (Supplemental Restraint System) such as the driver airbag and front passenger airbag. Failure to carry out service operation in the correct sequence could cause the SRS to unexpectedly deploy during servicing, possibly leading to a serious accident. Before servicing (including removal or installation of parts, inspection or replacement), be sure to read the precautionary notices in the RS section.

3. AUDIO SYSTEM

- If the negative (–) terminal cable is disconnected from the battery, the preset AM, FM 1 and FM 2 stations stored in memory are erased, so make sure to note the stations and reset them after the negative (–) terminal cable is reconnected to the battery.
- If the negative (–) terminal cable is disconnected from the battery, the "ANTI-THEFT SYSTEM" will operate when the cable is reconnected, but the radio, tape player and CD player will not operate. Be sure to input the correct ID number so that the radio, tape player and CD player can be operated again.

4. MOBILE COMMUNICATION SYSTEM

- If the vehicle is equipped with a mobile communication system, refer to precautions in the IN section.

PROBLEM SYMPTOMS TABLE**POWER OUTLET**

Symptom	Suspect Area	See page
Electric power source cannot be taken out of the power outlet	11. Battery	–
	12. POWER OUTLET Fuse (I/P J/B No.1)	–
	13. Wire Harness	–

HEADLIGHT AND TAILLIGHT SYSTEM (USA)

Symptom	Suspect Area	See page
Headlight does not light. (Taillight is normal)	1. HEAD–(LH, RH) Fuse (E/G Room J/B No.2) 2. Headlight Bulb 3. Wire Harness	– – –
Headlight does not light. (Taillight does not light up)	1. HEAD–(LH, RH) Fuse (E/G Room J/B No.2) 2. Headlight Control Relay (E/G Room J/B No.2) 3. Headlight Bulb 4. Wire Harness	– BE-24 – –
Only one side light does not light.	1. HEAD–(LH, RH) Fuse (E/G Room J/B No.2) 2. Headlight Bulb 3. Wire Harness	– – –
"Lo-Beam" does not light.	1. Headlight Bulb 2. Light Control Switch 3. Wire Harness	– BE-24 –
"Hi-Beam" does not light.	1. Headlight Dimmer Switch 2. Light Control Switch 3. Wire Harness	BE-24 BE-24 –
"Flash" does not light.	1. Headlight Dimmer Switch 2. Wire Harness	BE-24 –
"Auto Turn-off System" does not operate.	1. GAUGE Fuse (I/P J/B No.1) 2. DOME Fuse (E/G Room J/B No.2) 3. Integration Relay (I/P J/B No.2) 4. Door Courtesy Switch (Driver's) 5. Ignition Switch 6. Wire Harness	– – BE-14 BE-24 BE-14 –
Taillight does not light. (Headlight does not light)	1. Light Control Switch 2. Integration Relay (I/P J/B No.1) 3. Wire Harness	BE-24 BE-14 –
Taillight does not light. (Headlight is normal)	1. TAIL Fuse (I/P J/B No.1) 2. Taillight Control Relay (I/P J/B No.1) 3. Light Control Switch 4. Integration Relay (I/P J/B No.1) 5. Wire Harness	– BE-24 BE-24 BE-14 –
Only one side light does not light.	1. Bulb 2. Wire Harness	– –
Rear Combination light does not light.	1. Bulb 2. Light Failure Sensor 3. Wire Harness	– BE-37 –
"Auto Turn-off System" does not operate.	1. GAUGE Fuse (I/P J/B No.1) 2. Integration Relay (I/P J/B No.1) 3. Door Courtesy Switch (Driver's) 4. Wire Harness	– BE-14 BE-32 –

HEADLIGHT AND TAILLIGHT SYSTEM (CANADA)

Symptom	Suspect Area	See page
Headlight does not light. (Taillight is normal)	1. Wire Harness	–
Headlight does not light. (Taillight does not light up)	1. Wire Harness	–
Only one side light does not light.	1. Headlight Bulb 2. HEAD LO (LH, RH) Fuse (E/G Room R/B No.2) 3. Wire Harness	– – –
"Lo-Beam" does not light.	1. Headlight Bulb 2. HEAD LO (LH, RH) Fuse (E/G Room R/B No.2) 3. Headlight Control Relay (E/G Room J/B No.2) 4. Integration Relay (I/P J/B No.1) 5. Light Control Switch 6. Wire Harness	– – BE-24 BE-14 BE-24 –
"Hi-Beam" does not light.	1. Headlight Bulb 2. ECU-B Fuse (E/G Room J/B No.2) 3. HEAD HI (LH, RH) Fuse (E/G Room J/B No.2) 4. DRL Fuse (E/G Room R/B No.2) 5. Daytime Running Light Relay No.2 (E/G Room R/B No.2) 6. Daytime Running Light Relay No.3 (E/G Room R/B No.2) 7. Daytime Running Light Relay No.4 (E/G Room R/B No.2) 8. Daytime Running Light Relay (Main) 9. Headlight Dimmer Switch 10. Wire Harness	– – – – – BE-24 – BE-24 – BE-24 BE-24 BE-24 –
"Flash" does not light.	1. Headlight Bulb 2. ECU-B Fuse (E/G Room J/B No.2) 3. HEAD HI (LH, RH) Fuse (E/G Room J/B No.2) 4. DRL Fuse (E/G Room R/B No.2) 5. Daytime Running Light Relay No.2 (E/G Room R/B No.2) 6. Daytime Running Light Relay No.3 (E/G Room R/B No.2) 7. Daytime Running Light Relay No.4 (E/G Room R/B No.2) 8. Daytime Running Light Relay (Main) 9. Headlight Dimmer Switch 10. Wire Harness	– – – – – BE-24 – BE-24 – BE-24 BE-24 BE-24 –
"Auto Turn-off System" does not operate.	1. GAUGE Fuse (I/P J/B No.1) 2. DOME Fuse (E/G Room J/B No.2) 3. Integration Relay (I/P J/B No.2) 4. Door Courtesy Switch (Driver's) 5. Ignition Switch 6. Wire Harness	– – BE-14 BE-24 BE-14 –
Headlight does not light with engine running and light control SW OFF.	1. Headlight Bulb 2. ECU-B Fuse (E/G Room J/B No.2) 3. GAUGE Fuse (I/P J/B No.1) 4. HEAD HI (LH, RH) Fuse (E/G Room J/B No.2) 5. Daytime Running Light Relay (Main) 6. Wire Harness 7. Other Parts*	– – – – BE-24 – –

Taillight does not light. (Headlight does not light)	1. Integration Relay (I/P J/B No.1) 2. Light Control Switch 3. Wire Harness	BE-14 BE-24 –
Taillight does not light. (Headlight is normal)	1. TAIL Fuse (I/P J/B No.1) 2. Taillight Control Relay (I/P J/B No.1) 3. Integration Relay (I/P J/B No.1) 4. Light Control Switch 5. Wire Harness	– BE-24 BE-14 BE-24 –
Only one side light does not light.	1. Bulb 2. Wire Harness	– –
Rear Combination light does not light.	1. Bulb 2. Light Failure Sensor 3. Wire Harness	– BE-37 –
"Auto Turn-off System" does not operate.	1. GAUGE Fuse (I/P J/B No.1) 2. Integration Relay (I/P J/B No.1) 3. Door Courtesy Switch (Driver's) 4. Wire Harness	– BE-14 BE-24 –

*Terminal L of generator and parking brake switch

TURN SIGNAL AND HAZARD WARNING SYSTEM

Symptom	Suspect Area	See page
"Hazard" and "Turn" do not light up.	1. Hazard Warning Switch 2. Turn Signal Flasher 3. Wire Harness	BE-30 BE-30 –
The flashing frequency is abnormal.	1. Bulb 2. Turn Signal Switch 3. Wire Harness	– BE-30 –
Hazard warning light does not light up. (Turn is normal.)	1. HORN Fuse (E/G Room J/B No.2) 2. Wire Harness	– –
Hazard warning light does not light up in one direction.	1. Hazard Warning Switch 2. Wire Harness	BE-30 –
*1Turn signal does not light up.	1. Ignition Switch 2. TURN Fuse (I/P J/B No.1) 3. Turn Signal Switch 4. Wire Harness	BE-14 – BE-30 –
*2Turn signal does not light up.	1. TURN Fuse (I/P J/B No.1) 2. Turn Signal Switch 3. Wire Harness	– BE-30 –
Turn signal does not light up in one direction.	1. Turn Signal Switch 2. Wire Harness	BE-30 –
Only one bulb does not light up.	1. Bulb 2. Wire Harness	– –

*1: Combination meter, wiper and washer do not operate.

*2: Combination meter, wiper and washer are normal.

INTERIOR LIGHT SYSTEM

Symptom	Suspect Area	See page
"Illuminated Entry System" does not operate.	1. Door Courtesy Switch 2. Integration Relay (I/P J/B No.1) 3. Wire Harness	BE-32 BE-14 –
Only one interior light does not light up.	1. Bulb 2. Wire Harness	– –
Interior light does not light up (All).	1. DOME Fuse (E/G Room J/B No.2) 2. Wire Harness	– –

BODY ELECTRICAL – BODY ELECTRICAL SYSTEM

Dome light does not light up.	1. Bulb 2. Dome Light 3. Wire Harness	– BE-32 –
Map Light does not light up.	1. Bulb 2. Map Light 3. Wire Harness	– BE-32 –
Luggage compartment light does not light up.	1. Bulb 2. Luggage compartment door courtesy switch 3. Wire Harness	– BE-32 –

BACK-UP LIGHT SYSTEM

Symptom	Suspect Area	See page
Back-Up Light does not light up.	1. GAUGE Fuse (I/P J/B No.1) 2. Ignition Switch 3. Wire Harness 4. Bulb	– BE-14 – –
Back-Up Light remains always ON.	1. Back-Up Light Switch (M/T) 2. Park/Neutral Position Switch (A/T) (A140E) (A541E) 3. Wire Harness	BE-35 DI-424 DI-479 –
Only one light does not light up.	1. Bulb 2. Wire Harness	– –

STOP LIGHT SYSTEM

Symptom	Suspect Area	See page
Stop light does not light up.	1. STOP Fuse (I/P J/B No.1) 2. Stop Light Switch 3. Wire Harness	– BE-37 –
Only one light always lights up.	1. Wire Harness	–
Only one light does not light.	1. Bulb 2. Wire Harness	– –

WIPER AND WASHER SYSTEM

*1: Inspect wiper arm and blade set position

Symptom	Suspect Area	See page
Wiper and washers do not operate.	1. WIPER Fuse (I/P J/B No.1) 2. Wiper Switch 3. Wiper Motor 4. Wire Harness	– BE-40 BE-40 –
Wipers do not operate in LO or HI.	1. Wiper Switch 2. Wiper Motor 3. Wire Harness	BE-40 BE-40 –
Wipers do not operate in INT.	1. Wiper Switch 2. Wiper Motor 3. Wire Harness	BE-40 BE-40 –
Washer motor does not operate.	1. Washer Switch 2. Washer Motor 3. Wire Harness	BE-40 BE-40 –
Wipers do not operate when washer switch in ON.	1. Washer Motor 2. Wire Harness	BE-40 –

Washer fluid does not operate.	1. Washer Hose and Nozzle	–
<ul style="list-style-type: none"> In wiper switch HI position, the wiper blade is in contact with the body. When the wiper switch is OFF, the wiper blade does not retract or the retract position is wrong. 	<ol style="list-style-type: none"> *1 Wiper Switch Wire Harness 	<p>BE-40</p> <p>–</p>

COMBINATION METER

METER, GAUGES AND ILLUMINATION:

Symptom	Suspect Area	See page
Tachometer, Fuel Gauge and Engine Coolant Temperature Gauge do not operate.	<ol style="list-style-type: none"> GAUGE Fuse (I/P J/B No.1) Meter Circuit Plate Wire Harness 	<p>–</p> <p>BE-46</p> <p>–</p>
Speedometer does not operate.	<ol style="list-style-type: none"> No.1 Vehicle Speed Sensor Meter Circuit Plate Wire Harness 	<p>BE-47</p> <p>BE-46</p> <p>–</p>
Tachometer does not operate.	<ol style="list-style-type: none"> Igniter (5S-FE) (1MZ-FE) Meter Circuit Plate Wire Harness 	<p>IG-1</p> <p>IG-1</p> <p>BE-46</p> <p>–</p>
Fuel Gauge does not operate or abnormal operation.	<ol style="list-style-type: none"> Fuel Receiver Gauge Fuel Sender Gauge Meter Circuit Plate Wire Harness 	<p>BE-47</p> <p>BE-47</p> <p>BE-46</p> <p>–</p>
Engine Coolant Temperature Gauge does not operate or abnormal operation	<ol style="list-style-type: none"> Engine Coolant Temperature Receiver Gauge Engine Coolant Temperature Sender Gauge Meter Circuit Plate Wire Harness 	<p>BE-47</p> <p>BE-47</p> <p>BE-46</p> <p>–</p>
All illumination lights do not light up.	<ol style="list-style-type: none"> TAIL Fuse (I/P J/B No.1) Light Control Rheostat Wire Harness 	<p>–</p> <p>BE-47</p> <p>–</p>
Brightness does not change even when rheostat turned.	<ol style="list-style-type: none"> Bulb Wire Harness 	<p>–</p> <p>–</p>
Only one illumination light does not light up.	<ol style="list-style-type: none"> Bulb Wire Harness 	<p>–</p> <p>–</p>

COMBINATION METER

WARNING LIGHTS:

Symptom	Suspect Area	See page
Warning lights do not light up. (Except Discharge, Open Door and SRS)	<ol style="list-style-type: none"> GAUGE Fuse (I/P J/B No.1) Meter Circuit Plate Wire Harness 	<p>–</p> <p>BE-46</p> <p>–</p>
Low Oil Pressure warning light does not light up.	<ol style="list-style-type: none"> Bulb Low Oil Pressure Warning Switch Meter Circuit Plate Wire Harness 	<p>–</p> <p>BE-47</p> <p>BE-46</p> <p>–</p>
Fuel Level warning light does not light up.	<ol style="list-style-type: none"> Bulb Fuel Level Warning Switch Meter Circuit Plate Wire Harness 	<p>–</p> <p>BE-47</p> <p>BE-46</p> <p>–</p>
ABS warning light does not light up.	<ol style="list-style-type: none"> Bulb ABS ECU Wire Harness 	<p>–</p> <p>IN-31</p> <p>–</p>

BODY ELECTRICAL – BODY ELECTRICAL SYSTEM

Seat Belt warning light does not light up.	<ol style="list-style-type: none"> 1. Bulb 2. Seat Belt Buckle Switch 3. Integration Relay (I/P J/B No.1) 4. Wire Harness 	<p>–</p> <p>BE-47</p> <p>BE-47</p> <p>–</p>
Discharge warning light does not light up.	<ol style="list-style-type: none"> 1. IGN Fuse (I/P J/B No.1) 2. Bulb 3. Wire Harness 4. Generator (5S-FE) (1MZ-FE) 	<p>–</p> <p>–</p> <p>–</p> <p>CH-1</p> <p>CH-1</p>
Light Failure warning light does not light up.	<ol style="list-style-type: none"> 1. Bulb 2. Light Failure Sensor 3. Bulb Check Relay 4. Wire Harness 5. Taillight system 	<p>–</p> <p>BE-37</p> <p>BE-47</p> <p>–</p> <p>BE-24</p>
Brake warning light does not light up.	<ol style="list-style-type: none"> 1. Bulb 2. Parking Brake Switch 3. Brake Fluid Level Warning Switch 4. Bulb Check Relay 5. Meter Circuit Plate 6. Wire Harness 	<p>–</p> <p>BE-47</p> <p>BE-47</p> <p>BE-47</p> <p>BE-46</p> <p>–</p>
SRS Warning light does not light up.	<ol style="list-style-type: none"> 1. ECU-B Fuse (E/G Room J/B No.2) 2. Bulb 3. Airbag Sensor Assembly 4. Meter Circuit Plate 5. Wire Harness 	<p>–</p> <p>–</p> <p>DI-626</p> <p>BE-46</p> <p>–</p>
Open Door warning light does not light up.	<ol style="list-style-type: none"> 1. DOME Fuse (E/G Room J/B No.2) 2. Bulb 3. Door Courtesy Switch 4. Meter Circuit Plate 5. Wire Harness 	<p>–</p> <p>–</p> <p>BE-32</p> <p>BE-46</p> <p>–</p>
Washer Level warning light does not light up.	<ol style="list-style-type: none"> 1. Bulb 2. Washer Fluid Level Warning Switch 3. Meter Circuit Plate 4. Wire Harness 	<p>–</p> <p>BE-47</p> <p>BE-46</p> <p>–</p>

**COMBINATION METER
INDICATOR LIGHTS:**

Symptom	Suspect Area	See page
O/D OFF indicator light does not light up.	<ol style="list-style-type: none"> 1. Bulb 2. O/D OFF Switch (A140E) (A541E) 3. Meter Circuit Plate 4. Wire Harness 	<p>–</p> <p>DI-431</p> <p>DI-487</p> <p>BE-46</p> <p>–</p>
Cruise Control indicator light does not light up.	<ol style="list-style-type: none"> 1. Bulb 2. Cruise Control ECU 3. Meter Circuit Plate 4. Wire Harness 	<p>–</p> <p>IN-31</p> <p>BE-46</p> <p>–</p>
High beam indicator light does not light up.	<ol style="list-style-type: none"> 1. Bulb 2. Meter Circuit Plate 3. Wire Harness 4. Headlight System 	<p>–</p> <p>BE-46</p> <p>–</p> <p>BE-22</p>
Turn indicator light does not light up.	<ol style="list-style-type: none"> 1. Bulb 2. Meter Circuit Plate 3. Wire Harness 4. Turn Signal and Hazard Warning System 	<p>–</p> <p>BE-46</p> <p>–</p> <p>BE-29</p>

Shift indicator lights do not light up.	1. Bulb 2. Meter Circuit Plate 3. Park/Neutral Position Switch (A140E) (A541E) 4. Wire Harness	– BE-46 DI-424 DI-479 –
Only one shift indicator does not light up.	1. Bulb 2. Meter Circuit Plate	– BE-46
Malfunction indicator light does not light up.	1. Bulb 2. ECM 3. Meter Circuit Plate 4. Wire Harness	– – BE-46 –
SLIP indicator light does not light up.	1. Bulb 2. Traction ECU 3. Meter Circuit Plate 4. Wire Harness	– – BE-46 –
TRAC OFF indicator light does not light up.	1. Bulb 2. Traction ECU 3. Meter Circuit Plate 4. Wire Harness	– – BE-46 –
Security indicator light does not light up.	1. Bulb 2. Security ECU 3. Meter Circuit Plate 4. Wire Harness	– – BE-46 –
Indicator lights do not light up. (Except Turn, Hi-beam and security)	1. GAUGE Fuse (I/P J/B No.1) 2. Wire Harness	– –

DEFOGGER SYSTEM

Symptom	Suspect Area	See page
All defogger systems do not operate.	1. DEFOG M-Fuse (I/P J/B No.1) 2. HTR Fuse (I/P J/B No.1) 3. Defogger Relay (I/P J/B No.1) 4. Defogger Switch 5. Wire Harness	– – BE-56 BE-56 –
Rear window defogger does not operate.	1. Defogger Wire 2. Choke Coil 3. Wire Harness	BE-56 – –
Mirror defogger does not operate.	1. MIR/HTR Fuse (I/P J/B No.1) 2. Mirror Defogger 3. Wire Harness	– BE-56 –

POWER WINDOW CONTROL SYSTEM

Symptom	Suspect Area	See page
Power window does not operate (ALL). (Power Door Lock does not operate)	1. POWER M-Fuse (I/P J/B No.1) 2. Power Main Relay (I/P J/B No.1) 3. Wire Harness	– BE-60 –
Power window does not operate (ALL). (Power Door Lock is normal)	1. Ignition Switch 2. Power Window Master Switch 3. Wire Harness	BE-14 BE-60 –
"One Touch Power Window System" does not operate.	1. Power Window Master Switch	BE-60
Only one window glass does not move.	1. Power Window Master Switch 2. Power Window Switch 3. Power Window Motor 4. Wire Harness	BE-60 BE-60 BE-60 –
"Window Lock System" does not operate.	1. Power Window Master Switch	BE-60

BODY ELECTRICAL – BODY ELECTRICAL SYSTEM

"Window Lock Illumination" does not light up.	1. Power Window Master Switch	BE-60
Key-off power window does not operate.	1. GAUGE Fuse (I/P J/B No.1) 2. Integration Relay (I/P J/B No.1) 3. Ignition Switch 4. Door Courtesy Switch 5. Wire Harness	– BE-60 BE-14 BE-32 –

POWER DOOR LOCK CONTROL SYSTEM

Symptom	Suspect Area	See page
"Door lock system" does not operate at all.	1. POWER M-Fuse (I/P J/B No.1) 2. CIG Fuse (I/P J/B No.1) 3. DOOR Fuse (I/P J/B No.1) 4. Integration Relay (I/P J/B No.1) 5. Wire Harness	– – – BE-70 –
Door lock system does not operate by manual switch.	1. Power Window Master Switch 2. Door Lock Manual Switch 3. Integration Relay (I/P J/B No.1) 4. Wire Harness	BE-60 BE-70 BE-70 –
Door lock system does not operate by door key.	1. Door Key Lock and Unlock Switch 2. Integration Relay (I/P J/B No.1) 3. Wire Harness 4. Door Lock Link Disconnected	BE-70 BE-70 – –
Fault in 2-Operation unlock function of Driver's side door key lock and unlock switch.	1. Door Key Lock and Unlock Switch 2. Integration Relay (I/P J/B No.1) 3. Wire Harness	BE-70 BE-70 –
Fault in key confine prevention operate.	1. Integration Relay (I/P J/B No.1) 2. Key Unlock Warning Switch 3. Door Courtesy Switch 4. Wire Harness	BE-70 BE-14 BE-32 –
Only one door lock does not operate.	1. Door Lock Motor 2. Wire Harness	BE-70 –

SLIDING ROOF SYSTEM

Symptom	Suspect Area	See page
Sliding roof system does not operate. (Door Lock does not operate)	1. POWER M-Fuse (I/P J/B No.1) 2. Power Main Relay (I/P J/B No.1) 3. Wire Harness	– BE-60 –
Sliding roof system does not operate. (Door Lock is normal)	1. Ignition Switch 2. Sliding Roof Control Relay and Switch 3. Sliding Roof Motor and Limit Switch 4. Wire Harness	BE-14 BE-74 BE-74 –
Sliding roof system operates abnormally.	1. Sliding Roof Control Relay and Switch 2. Sliding Roof Motor and Limit Switch 3. Wire Harness	BE-74 BE-74 –
Sliding roof system stops operation half way. (Stones of foreign material trapped in motor assembly)	1. Sliding Roof Control Relay and Switch 2. Sliding Roof Motor and Limit Switch 3. Wire Harness	BE-74 BE-74 –
"Key-off Sliding Roof" operation does not operate.	1. DOME Fuse (E/G Room J/B No.2) 2. GAUGE Fuse (I/P J/B No.1) 3. Ignition Switch 4. Integration Relay (I/P J/B No.1) 5. Wire Harness	– – BE-14 BE-14 –

POWER SEAT CONTROL SYSTEM

Symptom	Suspect Area	See page
Power seat does not operate. (Door lock system does not operate)	1. POWER M-Fuse (I/P J/B No.1) 2. Wire Harness	– –
Power seat does not operate. (Door lock system is normal)	1. Power Seat Switch (D,P) 2. Wire Harness	BE-78 –
"Slide operation" does not operate.	1. Power Seat Switch (D, P) 2. Wire Harness 3. Slide Motor (D, P)	BE-78 – BE-78
"Lifter Operation" does not operate.	1. Power Seat Switch (D, P) 2. Wire Harness 3. Lifter Motor (D, P)	BE-78 – BE-78
"Reclining Operation" does not operate.	1. Power Seat Switch (D, P) 2. Wire Harness 3. Reclining Motor (D, P)	BE-78 – BE-78

(D): Driver's seat

(P): Passenger's seat

POWER MIRROR CONTROL SYSTEM

Symptom	Suspect Area	See page
Mirror does not operate.	1. CIG Fuse (I/P J/B No.1) 2. Mirror Switch 3. Mirror Motor 4. Wire Harness	– BE-83 BE-83 –
Mirror operates abnormally.	1. Mirror Switch 2. Mirror Motor 3. Wire Harness	BE-83 BE-83 –

POWER SOURCE LOCATION

BE0A0-03

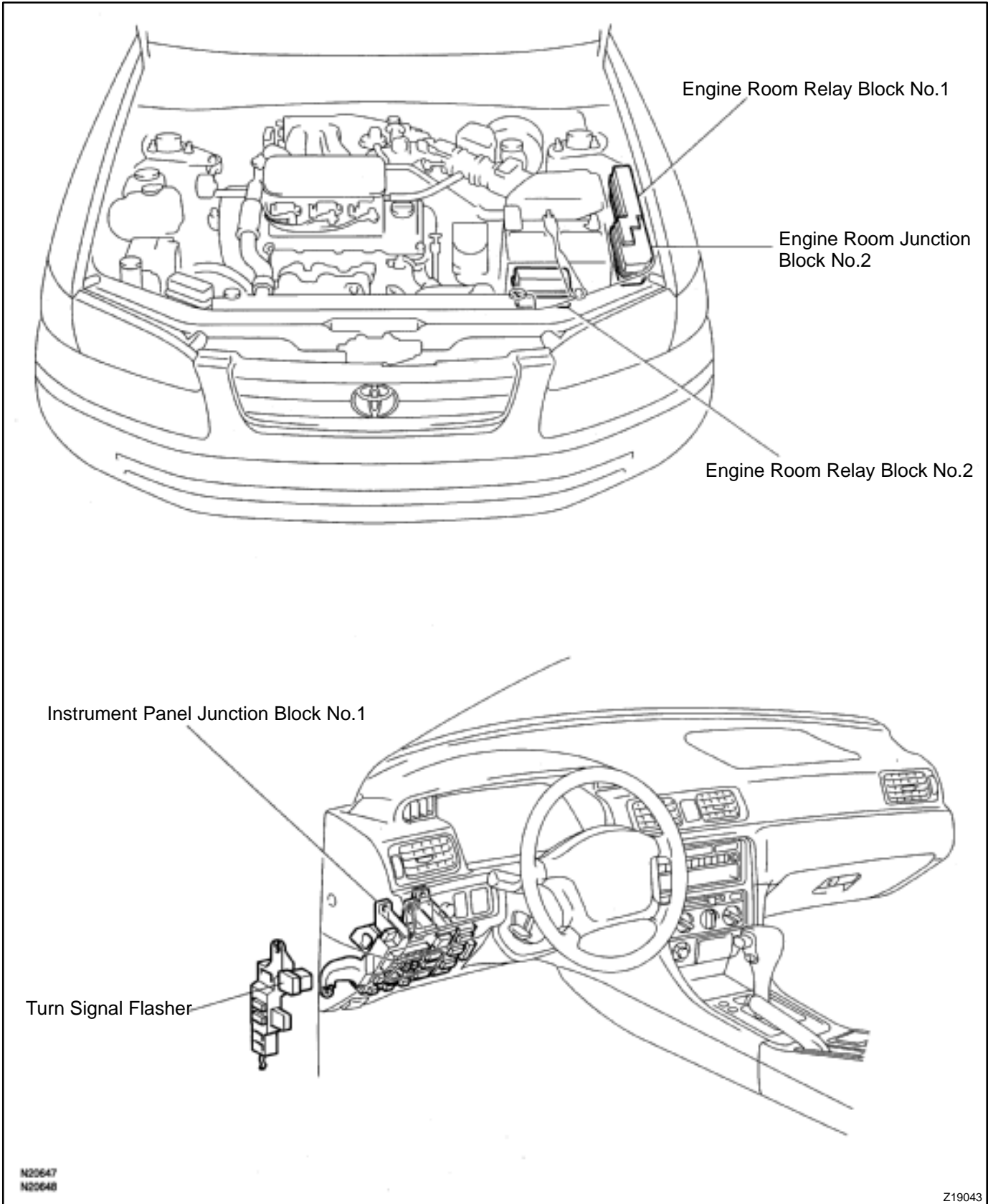

N20647
N20648

Z19043

POWER OUTLET LOCATION

BE0A1-03

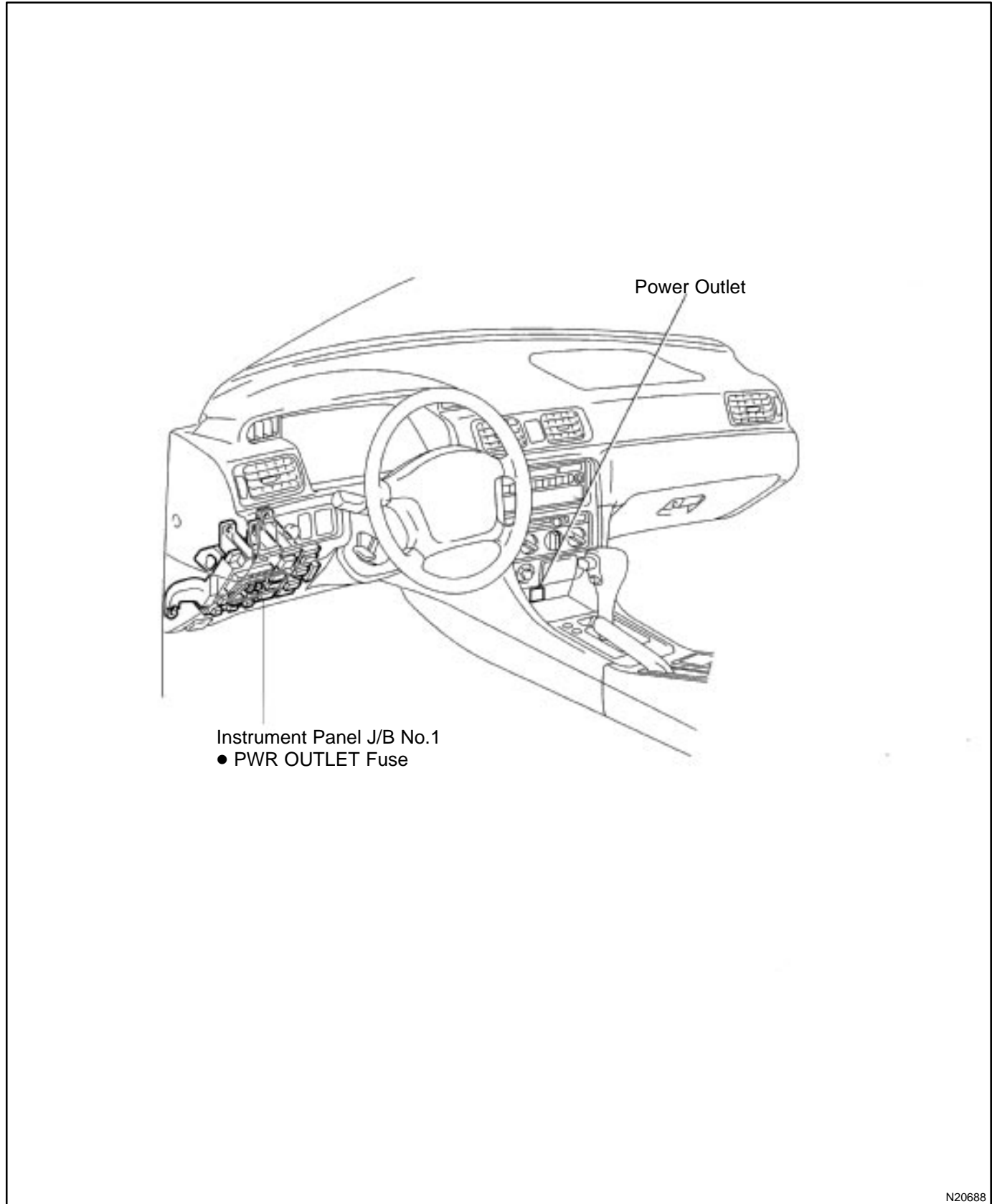

N20688

IGNITION SWITCH AND KEY UNLOCK WARNING SWITCH LOCATION

BE0A2-03

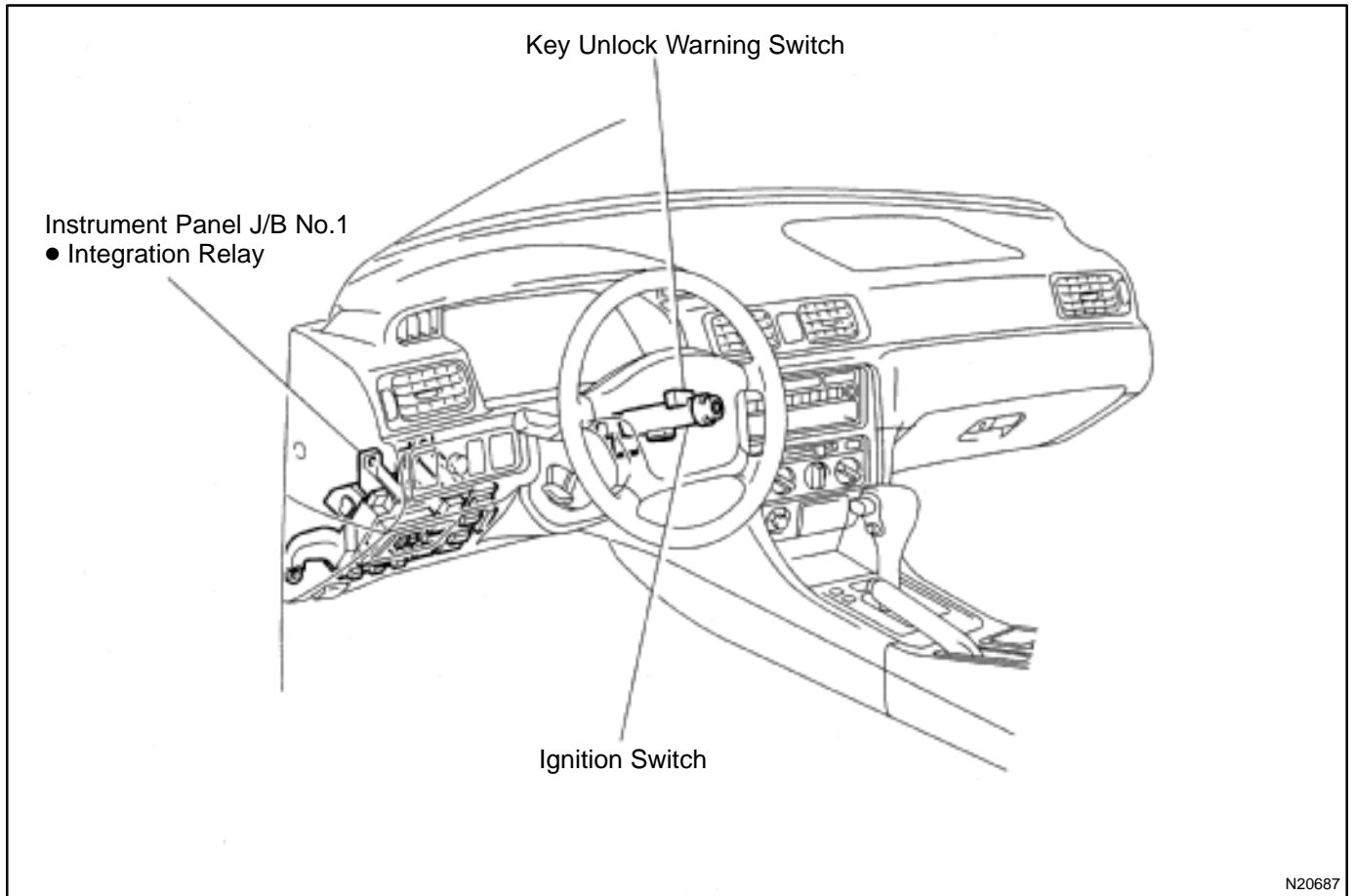

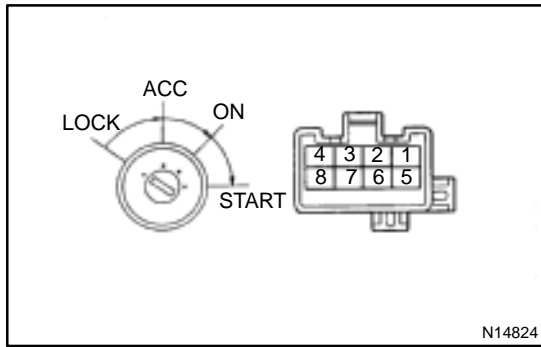

INSPECTION

1. INSPECT IGNITION SWITCH CONTINUITY

Switch position	Tester connection	Specified condition
LOCK	–	No continuity
ACC	2–3	Continuity
ON	2–3–4 6–7	Continuity
START	1–2–4 6–7–8	Continuity

If continuity is not as specified, replace the switch.

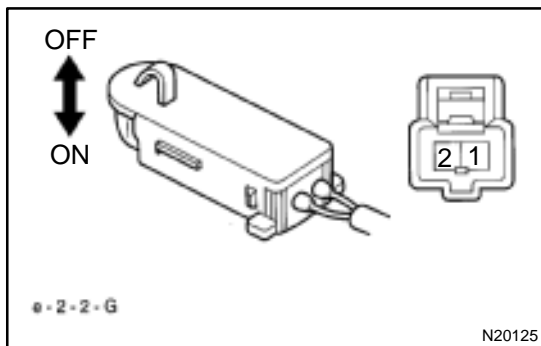

2. INSPECT KEY UNLOCK WARNING SWITCH CONTINUITY

Switch position	Tester connection	Specified condition
OFF (Key removed)	–	No continuity
ON (Key set)	1–2	Continuity

If continuity is not as specified, replace the switch.

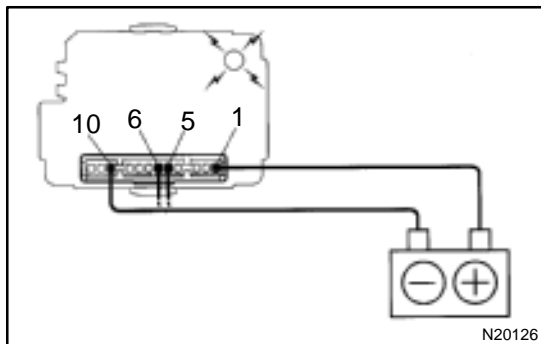

3. Key unlock warning system: INSPECT INTEGRATION RELAY (TYPE A) OPERATION

- Connect the positive (+) lead from the battery to terminal 1.
- Connect the negative (–) lead from the battery to terminals 5, 6 and 10.
- Check the buzzer sounds.

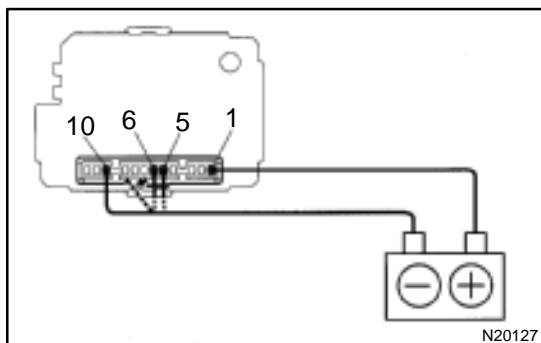

- Disconnect the negative (–) lead from the battery to terminal 6.
- Check that the buzzer stops sounding.

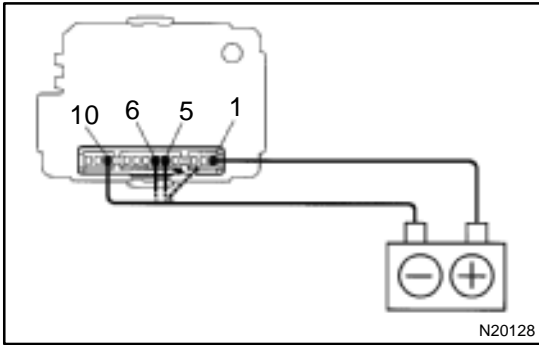

- (f) Connect the negative (-) lead from the battery to terminal 6.
- (g) Disconnect the negative (-) lead from the battery to terminal 5.
- (h) Check that the buzzerr stops sounding.
If operation is not as specified, replace the relay.

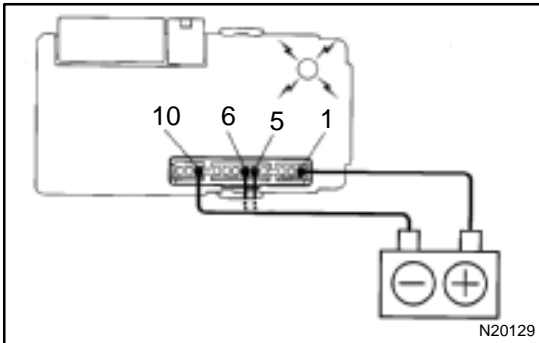

**4. Key unlock warning system:
INSPECT INTEGRATION RELAY (TYPE B) OPERATION**

- (a) Connect the positive (+) lead from the battery to terminal 1.
- (b) Connect the negative (-) lead from the battery to terminals 5, 6 and 10.
- (c) Check the buzzerr sounds.

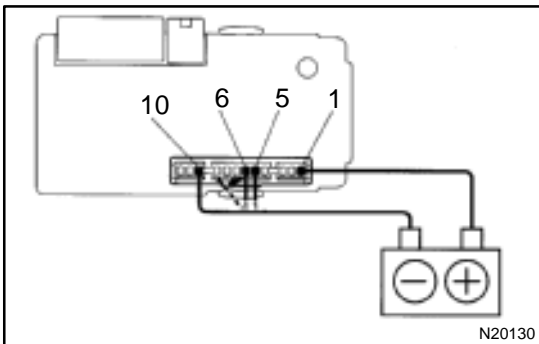

- (d) Disconnect the negative (-) lead from the battery to terminal 6.
- (e) Check that the buzzerr stops sounding.

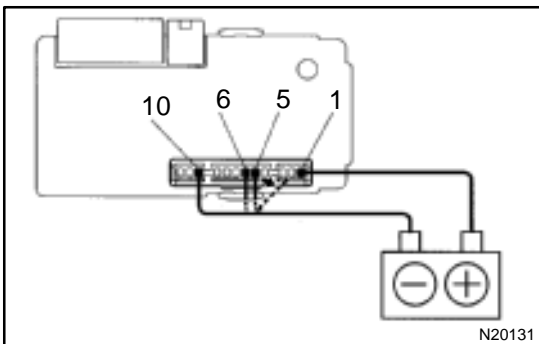

- (f) Connect the negative (-) lead from the battery to terminal 6.
- (g) Disconnect the negative (-) lead from the battery to terminal 5.
- (h) Check that the buzzerr stops sounding.
If operation is not as specified, replace the relay.

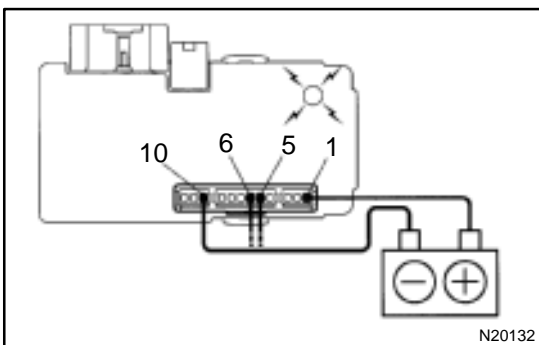

**5. Key unlock warning system:
INSPECT INTEGRATION RELAY (TYPE C) OPERATION**

- (a) Connect the positive (+) lead from the battery to terminal 1.
- (b) Connect the negative (-) lead from the battery to terminals 5, 6 and 10.
- (c) Check the buzzerr sounds.

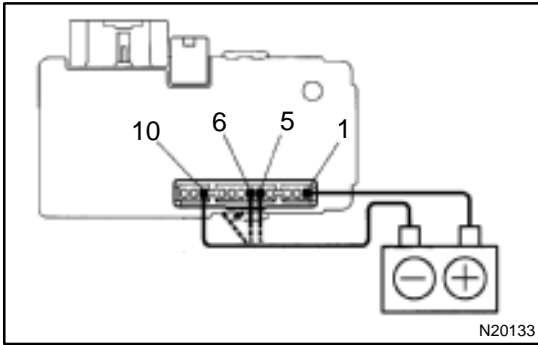

- (d) Disconnect the negative (-) lead from the battery to terminal 6.
- (e) Check that the buzzerr stops sounding.

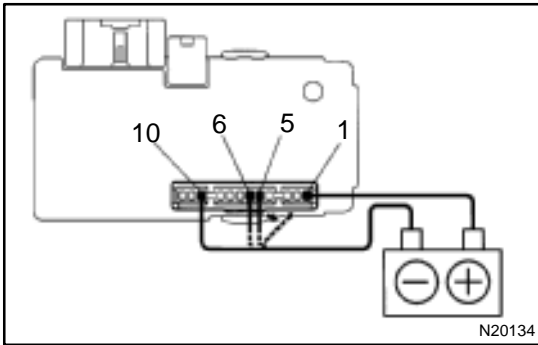

- (f) Connect the negative (-) lead from the battery to terminal 6.
- (g) Disconnect the negative (-) lead from the battery to terminal 5.
- (h) Check that the buzzerr stops sounding. If operation is not as specified, replace the relay.

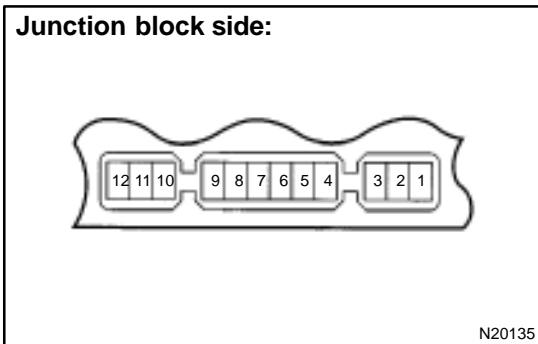

- 6. INSPECT INTEGRATION RELAY (TYPE A) CIRCUIT**
- (a) Remove the relay from the junction block No.1 and inspect the connector on the junction block side.

Tester connection	Condition	Specified condition
2 – Ground 4 – Ground	Passenger's door courtesy switch OFF (Door closed)	No continuity
2 – Ground 4 – Ground	Passenger's door courtesy switch ON (Door opened)	Continuity
5 – Ground	Key unlock warning switch OFF	No continuity
5 – Ground	Key unlock warning switch ON	Continuity
6 – Ground	Driver's door courtesy switch OFF	No continuity
6 – Ground	Driver's door courtesy switch ON	Continuity
8 – Ground	Buckle switch OFF (Seat belt unfastened)	No continuity
8 – Ground	Buckle switch ON (Seat belt fastened)	Continuity
10 – Ground	Constant	Continuity
1 – Ground	Constant	Battery positive voltage
7 – Ground 9 – Ground	Ignition switch LOCK or ACC	No voltage
7 – Ground 9 – Ground	Ignition switch ON	Battery positive voltage

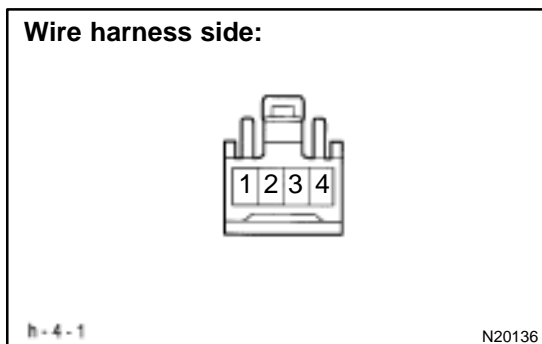

- (b) Disconnect the connector from the integration relay and inspect the connector on the wire harness side.

Tester connection	Condition	Specified condition
1 – Ground	Light control switch OFF	No continuity
1 – Ground	Light control switch HEAD or TAIL	Continuity
4 – Ground	Light control switch OFF or TAIL	No continuity
4 – Ground	Light control switch HEAD	Continuity
2 – Ground 3 – Ground	Constant	Battery positive voltage

If the circuit is as specified, try replacing the relay with a new one.

If the circuit is not as specified, inspect the circuits connected to other parts.

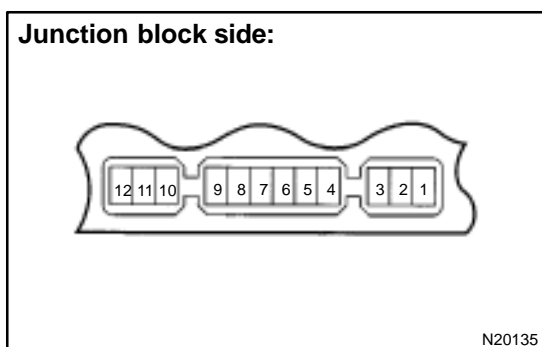

7. INSPECT INTEGRATION RELAY (TYPE B) CIRCUIT

- (a) Remove the relay from the junction block No.1 and inspect the connector on the junction block side.

Tester connection	Condition	Specified condition
2 – Ground	All door courtesy switches OFF (Except Driver's Door/ Door closed)	No continuity
2 – Ground	One of the door courtesy switches ON (Except Driver's Door/ Door opened)	Continuity
4 – Ground	Door courtesy switches except that of the driver's door OFF (Door closed)	No continuity
4 – Ground	One of the door courtesy switches except that of the driver's door ON (Door opened)	Continuity

5 – Ground	Key unlock warning switch OFF	No continuity
5 – Ground	Key unlock warning switch ON	Continuity
6 – Ground	Driver's door courtesy switch OFF (Door closed)	No continuity
6 – Ground	Driver's door courtesy switch ON (Door opened)	Continuity
8 – Ground	Buckle switch OFF (Seat belt unfastened)	No continuity
8 – Ground	Buckle switch ON (Seat belt fastened)	Continuity
10 – Ground	Constant	Continuity
1 – Ground	Constant	Battery positive voltage
7 – Ground 9 – Ground	Ignition switch LOCK or ACC	No voltage
7 – Ground 9 – Ground	Ignition switch ON	Battery positive voltage
11 – Ground	Ignition switch LOCK	No voltage
11 – Ground	Ignition switch ACC or ON	Battery positive voltage

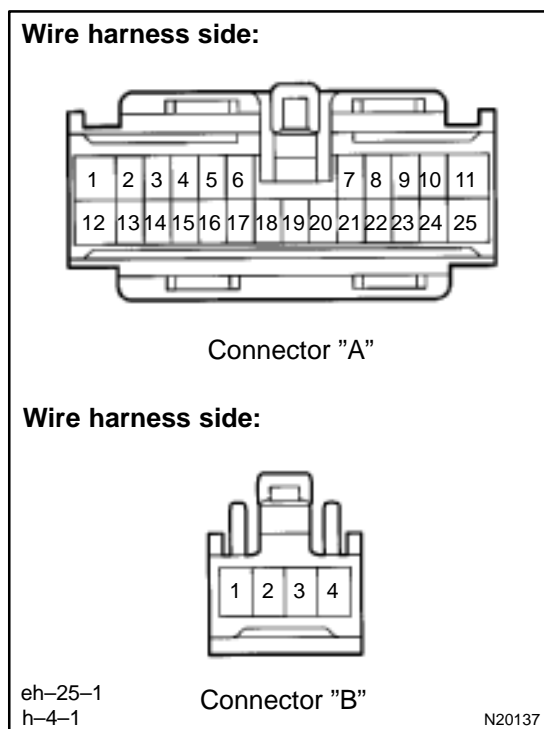

(b) Disconnect the connector from the integration relay and inspect the connectors on the wire harness side.

Tester connection	Condition	Specified condition
A3 – Ground	Constant	Continuity
A5 – Ground	Driver's door unlock detection switch OFF (Door locked)	No continuity
A5 – Ground	Driver's door unlock detection switch ON (Door unlocked)	Continuity
A6 – Ground	Passenger's door courtesy switch OFF (Door closed)	No continuity

A6 – Ground	Passenger's door courtesy switch ON (Door opened)	Continuity
A7 – Ground	Passenger's door unlock detection switch OFF (Door locked)	No continuity
A7 – Ground	Passenger's door unlock detection switch ON (Door unlocked)	Continuity
A9 – Ground	Rear door unlock detection switch OFF (Door locked)	No continuity
A9 – Ground	Rear door unlock detection switch ON (Door unlocked)	Continuity
A11 – A12 A12 – A25	Constant	Continuity
A16 – Ground	Door lock manual switch OFF or UNLOCK	No continuity
A16 – Ground	Door lock manual switch LOCK	Continuity
A17 – Ground	Door lock manual switch OFF or LOCK	No continuity
A17 – Ground	Door lock manual switch UNLOCK	Continuity
A18 – Ground	Driver's and passenger's door key lock and unlock switch OFF or UNLOCK	No continuity
A18 – Ground	Driver's or passenger's door key lock and unlock switch LOCK	Continuity
A19 – Ground	Driver's door key lock and unlock switch OFF or LOCK	No continuity
A19 – Ground	Driver's door key lock and unlock switch UNLOCK	Continuity
A20 – Ground	Passenger's door key lock and unlock switch OFF or LOCK	No continuity
A20 – Ground	Passenger's door key lock and unlock switch UNLOCK	Continuity
A1 – Ground	Constant	Battery positive voltage
B1 – Ground	Light control switch OFF	No voltage
B1 – Ground	Light control switch TAIL or HEAD	Battery positive voltage
B4 – Ground	Light control switch OFF or TAIL	No voltage
B4 – Ground	Light control switch HEAD	Battery positive voltage
B2 – Ground B3 – Ground	Constant	Battery positive voltage

If the circuit is as specified, try replacing the relay with a new one.

If the circuit is not as specified, inspect the circuits connected to other parts.

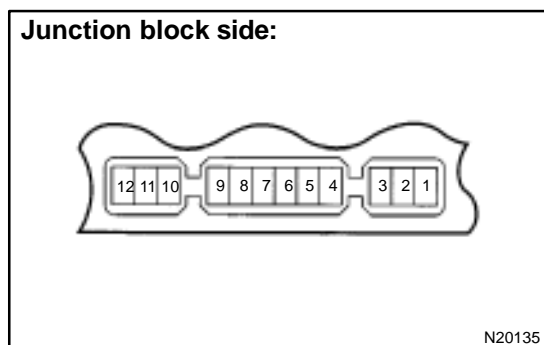

8. INSPECT INTEGRATION RELAY (TYPE C) CIRCUIT

- (a) Remove the relay from the junction block No.1 and inspect the connector on the junction block side.

Tester connection	Condition	Specified condition
2 – Ground	All door courtesy switches OFF (Except Driver's Door/ Door closed)	No continuity
2 – Ground	One of the door courtesy switches ON (Except Driver's Door/ Door opened)	Continuity
4 – Ground	Door courtesy switches except that of the driver's door OFF (Door closed)	No continuity
4 – Ground	One of the door courtesy switches except that of the driver's door ON (Door opened)	Continuity
5 – Ground	Key unlock warning switch OFF	No continuity
5 – Ground	Key unlock warning switch ON	Continuity
6 – Ground	Driver's door courtesy switch OFF (Door closed)	No continuity
6 – Ground	Driver's door courtesy switch ON (Door opened)	Continuity
8 – Ground	Buckle switch OFF (Seat belt unfastened)	No continuity
8 – Ground	Buckle switch ON (Seat belt fastened)	Continuity
10 – Ground	Constant	Continuity
1 – Ground	Constant	Battery positive voltage
7 – Ground 9 – Ground	Ignition switch LOCK or ACC	No voltage
7 – Ground 9 – Ground	Ignition switch ON	Battery positive voltage
11 – Ground	Ignition switch LOCK	No voltage
11 – Ground	Ignition switch ACC or ON	Battery positive voltage

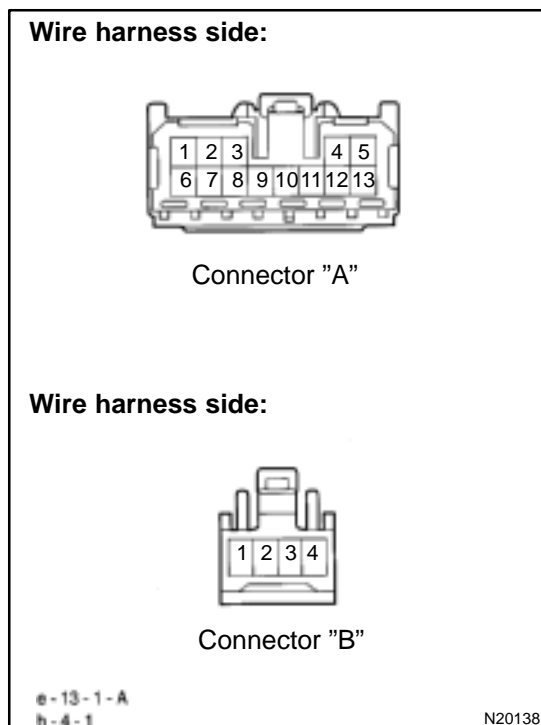

- (b) Disconnect the connector from the integration relay and inspect the connectors on the wire harness side.

Tester connection	Condition	Specified condition
A1 – Ground	Door lock manual switch OFF or UNLOCK	No continuity
A1 – Ground	Door lock manual switch LOCK	Continuity
A2 – Ground	Door lock manual switch OFF or LOCK	No continuity
A2 – Ground	Door lock manual switch UNLOCK	Continuity
A3 – Ground	Driver's and passenger's door key lock and unlock switch OFF or UNLOCK	No continuity
A3 – Ground	Driver's or passenger's door key lock and unlock switch LOCK	Continuity
A4 – Ground	Driver's door key lock and unlock switch OFF or LOCK	No continuity
A4 – Ground	Driver's door key lock and unlock switch UNLOCK	Continuity
A5 – Ground	Passenger's door key lock and unlock switch OFF or LOCK	No continuity
A5 – Ground	Passenger's door key lock and unlock switch UNLOCK	Continuity
A6 – A7	Constant	Continuity
A8 – Ground	Passenger's door courtesy switch OFF (Door closed)	No continuity
A8 – Ground	Passenger's door courtesy switch ON (Door opened)	Continuity
A9 – Ground	Driver's door unlock detection switch OFF (Door closed)	No continuity
A9 – Ground	Driver's door unlock detection switch ON (Door opened)	Continuity
A10 – Ground	Passenger's door unlock detection switch OFF (Door closed)	No continuity
A10 – Ground	Passenger's door unlock detection switch ON (Door opened)	Continuity
A11 – Ground	Rear door unlock detection switch OFF (Door closed)	No continuity
A11 – Ground	Rear door unlock detection switch ON (Door opened)	Continuity
A12 – Ground	Constant	Continuity
A13 – Ground	Constant	Battery positive voltage
B1 – Ground	Light control switch OFF	No voltage
B1 – Ground	Light control switch TAIL or HEAD	Battery positive voltage
B4 – Ground	Light control switch OFF or TAIL	No voltage
B4 – Ground	Light control switch HEAD	Battery positive voltage
B2 – Ground B3 – Ground	Constant	Battery positive voltage

If the circuit is as specified, try replacing the relay with a new one.

If the circuit is not as specified, inspect the circuits connected to other parts.

HEADLIGHT AND TAILLIGHT SYSTEM LOCATION

BE044-02

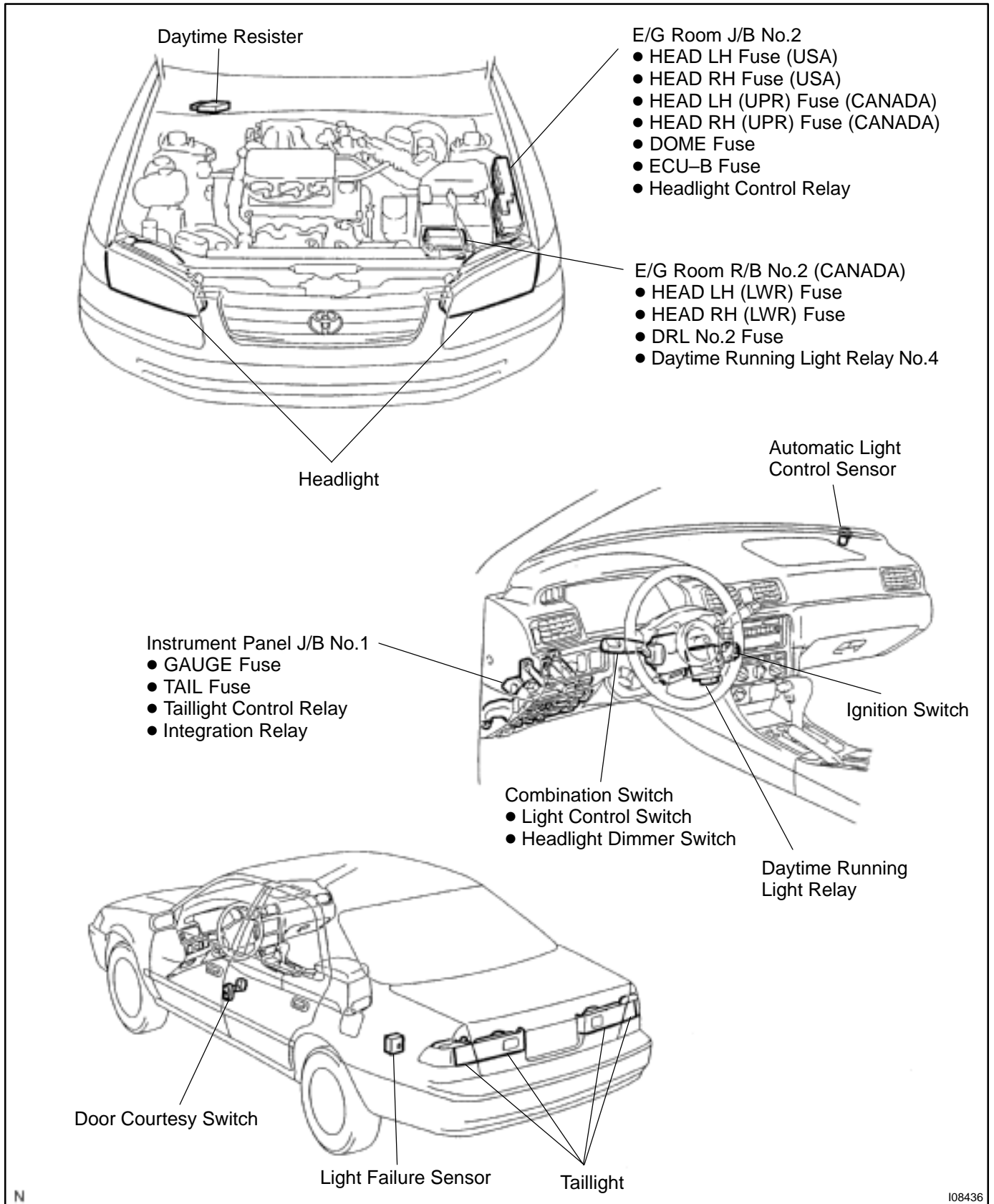

N

108436

COMPONENTS

- Combination Switch
- Light Control Switch
 - Headlight Dimmer Switch

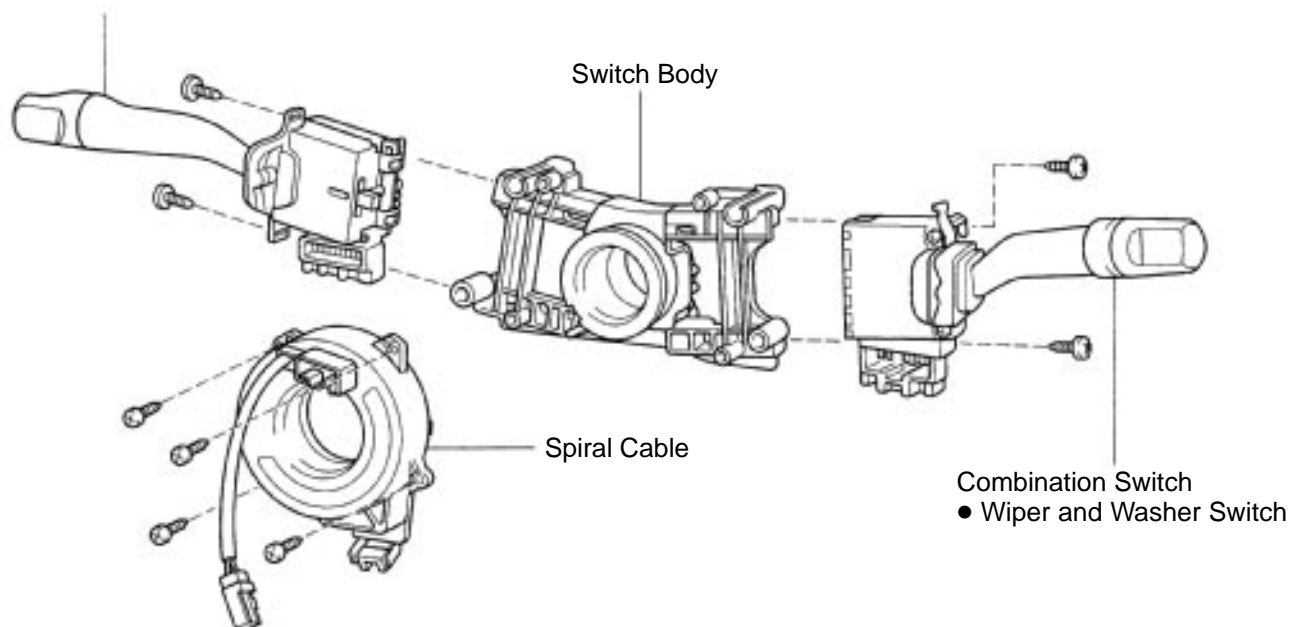

N18012

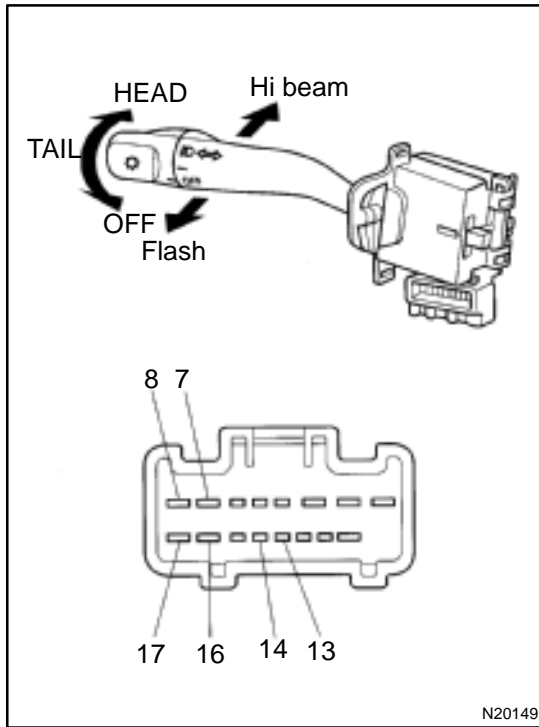

INSPECTION

1. INSPECT LIGHT CONTROL SWITCH CONTINUITY

Switch position	Tester connection	Specified condition
OFF	-	No continuity
TAIL	14 - 16	Continuity
HEAD	13 - 14 - 16	Continuity

If continuity is not as specified, replace the switch.

2. INSPECT HEADLIGHT DIMMER SWITCH CONTINUITY

Switch position	Tester connection	Specified condition
Low beam	16 - 17	Continuity
High beam	7 - 16	Continuity
Flash	7 - 8 - 16	Continuity

If continuity is not as specified, replace the switch.

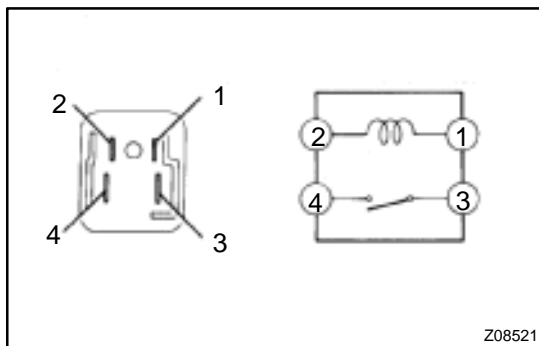

3. INSPECT HEADLIGHT CONTROL RELAY CONTINUITY

Condition	Tester connection	Specified condition
Constant	1 - 2	Continuity
Apply B+ between terminals 1 and 2.	3 - 4	Continuity

If continuity is not as specified, replace the relay.

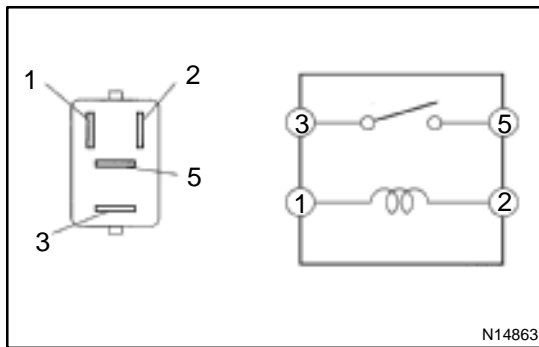

4. INSPECT TAILLIGHT CONTROL RELAY CONTINUITY

Condition	Tester connection	Specified condition
Constant	1 - 2	Continuity
Apply B+ between terminals 1 and 2.	3 - 5	Continuity

If continuity is not as specified, replace the relay.

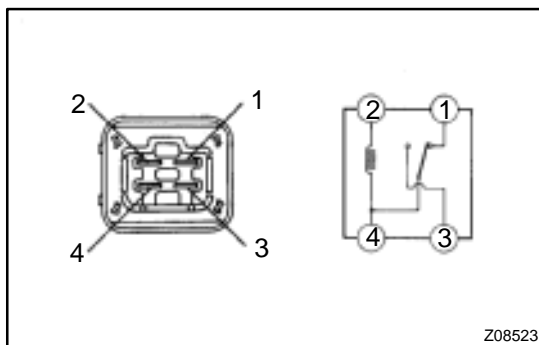

5. INSPECT HEADLIGHT DIMMER RELAY CONTINUITY

Condition	Tester connection	Specified condition
Constant	1 - 4, 2 - 4	Continuity
Apply B+ between terminals 2 and 4.	3 - 4	Continuity

If continuity is not as specified, replace the relay.

Wire harness side:



Y

I08219

6. INSPECT DAYTIME RUNNING LIGHT RELAY (MAIN) CIRCUIT

Disconnect the connector from the relay and inspect the connector on the wire harness side.

Tester connection	Condition	Specified condition
2 – Ground	Light control switch position OFF or TAIL	No continuity
2 – Ground	Light control switch position HEAD	Continuity
3 – Ground	Headlight dimmer switch position Low beam	No continuity
3 – Ground	Headlight dimmer switch position High beam or Flash	Continuity
4 – Ground	Brake fluid level warning position OFF	No continuity
4 – Ground	Brake fluid level warning position ON	Continuity
12 – Ground	Constant	Continuity
14 – Ground	Parking brake switch position OFF (Parking brake lever released)	No continuity
14 – Ground	Parking brake switch position ON (Parking brake lever pulled up)	Continuity
17 – Ground	Light control switch position OFF or HEAD	No voltage
17 – Ground	Light control switch position TAIL	Continuity
20 – Ground	Constant	Continuity
21 – Ground	Constant	Continuity
13 – Ground	Engine Stop	No voltage
13 – Ground	Engine Running	Battery positive voltage
16 – Ground	Constant	Battery positive voltage
18 – Ground	Ground terminal 19	Battery positive voltage
19 – Ground	Constant	Battery positive voltage
22 – Ground	Constant	Battery positive voltage
23 – Ground	Ignition switch position LOCK or ACC	No voltage
23 – Ground	Ignition switch position ON or START	Battery positive voltage

If circuit is as specified, try replacing the relay with a new one. If circuit is not as specified, inspect the circuits connected to other parts.

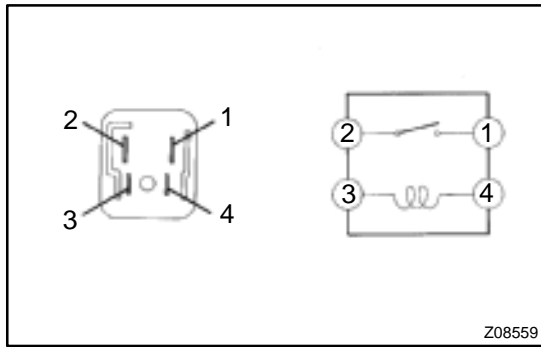

7. INSPECT DAYTIME RUNNING LIGHT NO.4 RELAY CONTINUITY

Condition	Tester connection	Specified condition
Constant	3 – 4	Continuity
Apply B+ between terminals 3 and 4.	1 – 2	Continuity

If continuity is not as specified, replace the relay.

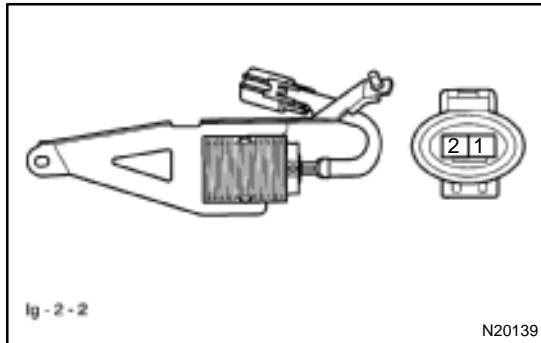

8. INSPECT DAYTIME RUNNING LIGHT RESISTER CONTINUITY

Condition	Tester connection	Specified condition
Constant	1 – 2	Approx. 250mΩ

If continuity is not as specified, replace the resistor.

9. INSPECT LIGHT AUTO TURN OFF SYSTEM (See Integration relay circuit on page BE-14)

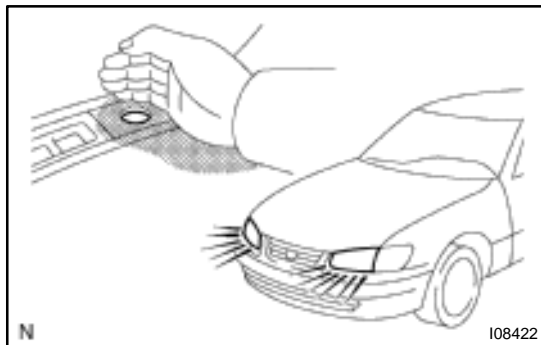

10. INSPECT AUTOMATIC LIGHT CONTROL

- (a) Turn the ignition switch ON.
- (b) Turn the light control switch to OFF.
- (c) Parking brake lever released.
- (d) Gradually cover the top of the sensor.
- (e) Verify that the lights should turn ON the accessory lights and the headlights.

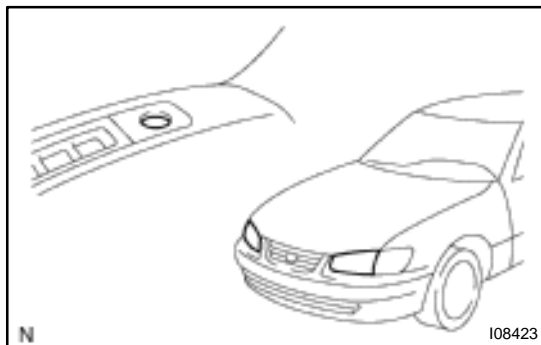

11. INSPECT AUTOMATIC LIGHT CONTROL

- (a) Gradually expose the sensor.
- (b) Verify that the lights should turn OFF the headlights and the accessory lights.

12. INSPECT LIGHT-OFF CONDITION

- (a) Turn the ignition switch ON.
- (b) Gradually cover the top of the sensor.
Lights auto ON:

13. INSPECT LIGHTS-ON CONDITION

- (a) Open the driver's door while the ignition switch is OFF.
- (b) Turn the light control switch to OFF leaving the door open and cover the top of the sensor, and verify that the lights go on when the ignition switch is turned ON.

Wire harness side:



I01254

14. INSPECT AUTOMATIC LIGHT CONTROL SENSOR CIRCUIT

Connector disconnected:

Disconnect the connector from the sensor and inspect the connector on the wire harness side, as shown in the table.

Tester connection	Condition	Specified condition
3 – Ground	Constant	Constant
1 – Ground	Ignition switch LOCK or ACC	No voltage
1 – Ground	Ignition switch ON	Battery positive voltage
4 – Ground	Ignition switch LOCK or ACC	No voltage
4 – Ground	Ignition switch ON	5.2 – 9.0 v

If circuit is as specified, perform the inspection on the following page.

If the circuit is not as specified, inspect the circuit connected to other parts.

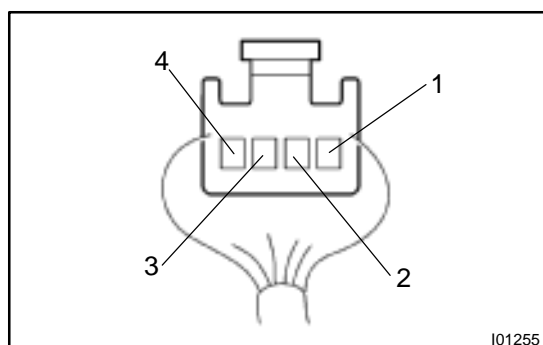

I01255

15. INSPECT AUTOMATIC LIGHT CONTROL SENSOR CIRCUIT

Connector disconnected:

Connect the wire harness side connector to the sensor and inspect wire harness side connector from the back side, as shown.

HINT:

- Ignition switch ON.
- Light control switch OFF.
- Vehicle's surroundings are bright.

Tester connection	Condition	Specified condition
3 – Ground	Constant	Continuity
1 – Ground	Ignition switch LOCK or ACC	No voltage
1 – Ground	Ignition switch ON	9.5 V or more
Vehicle under the direct sun light. (Sensor is not covered)		Taillight and Headlight are ON.

If circuit is as specified, try replacing the sensor with a new one.
If the circuit is not as specified, inspect the circuit connected to other parts.

ADJUSTMENT

1. ADJUST HEADLIGHT AIMING

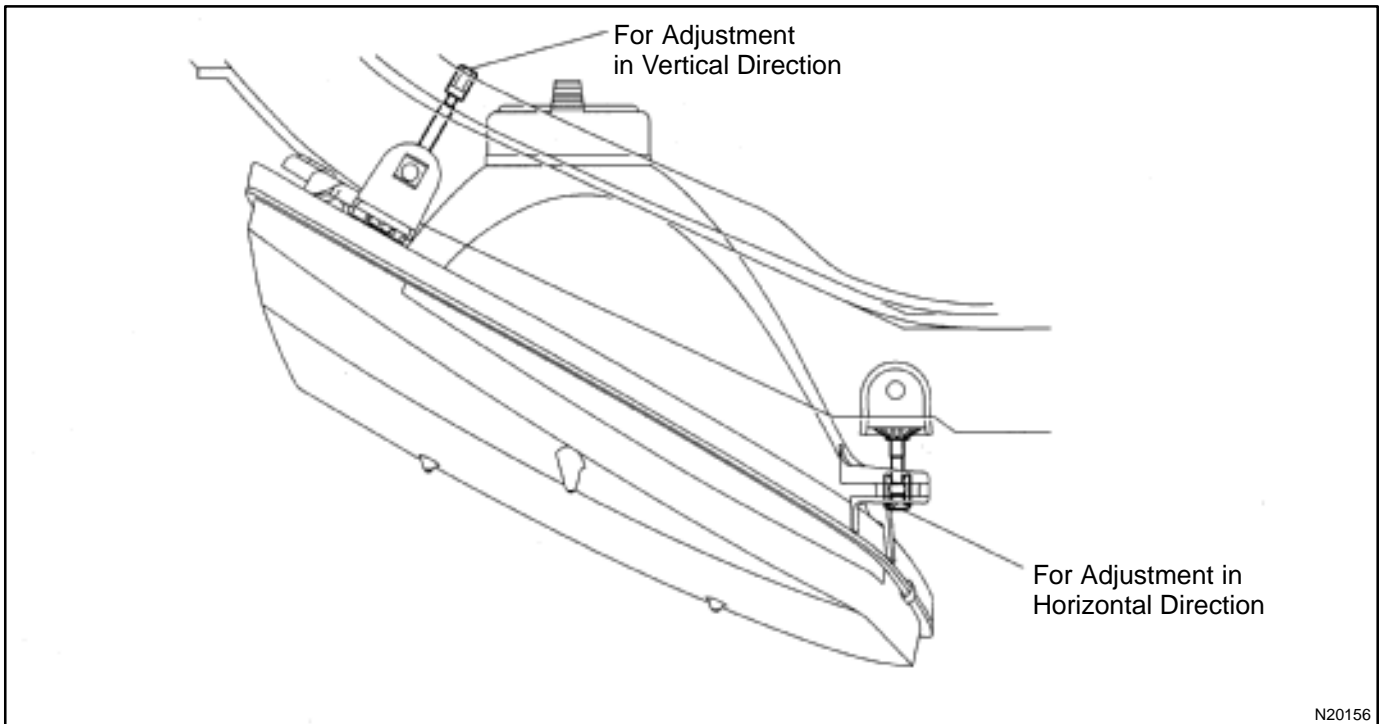

2. ADJUST SPIRAL CABLE (See page [SR-16](#))

TURN SIGNAL AND HAZARD WARNING SYSTEM LOCATION

BE0A8-03

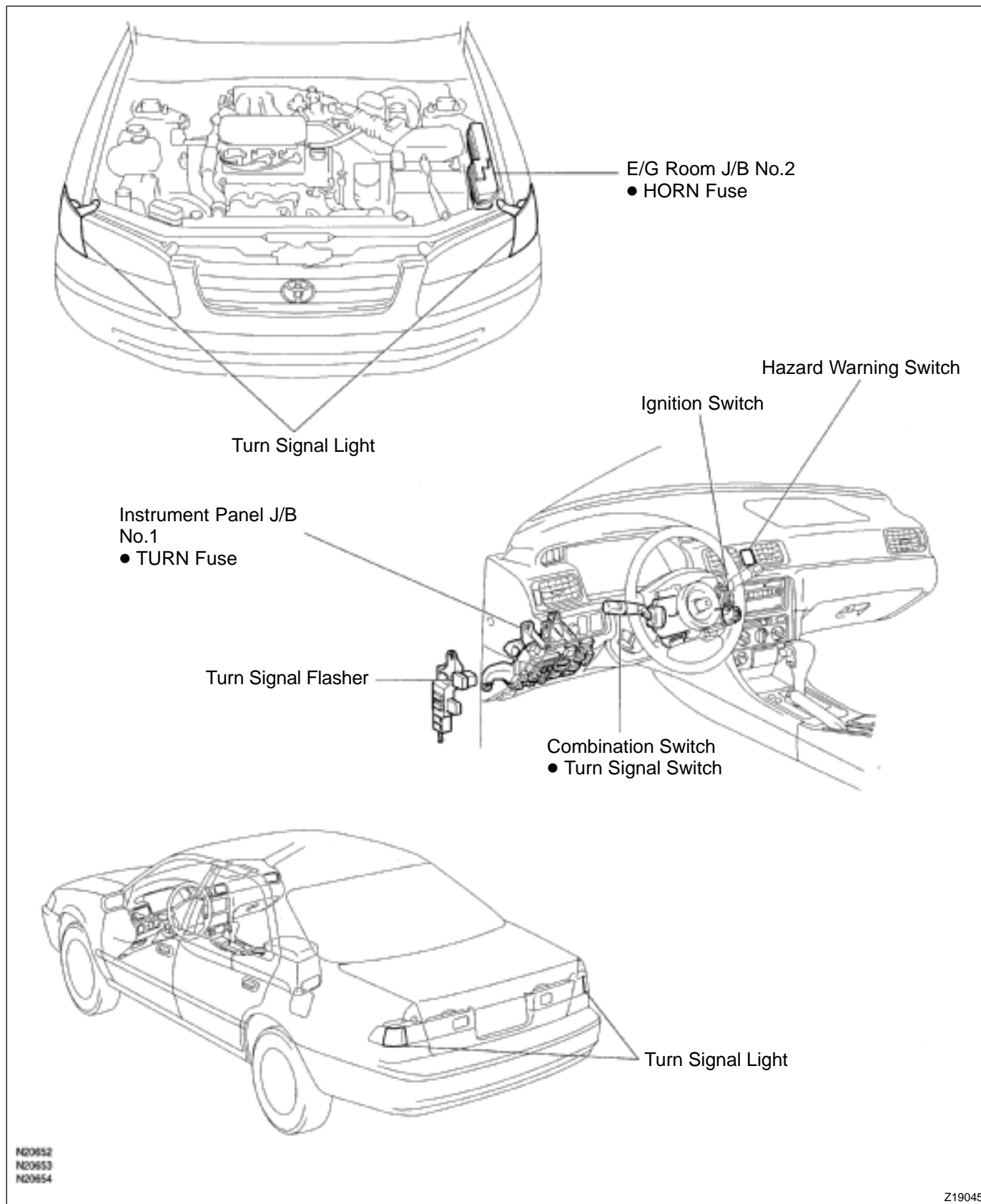

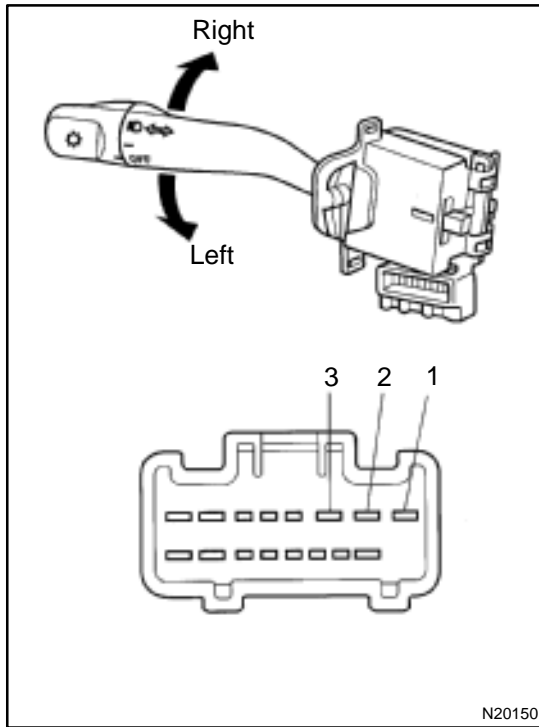

INSPECTION

1. INSPECT TURN SIGNAL SWITCH CONTINUITY

Switch position	Tester connection	Specified condition
Left turn	1 – 2	Continuity
Neutral	–	No continuity
Right turn	2 – 3	Continuity

If continuity is not as specified, replace the switch.

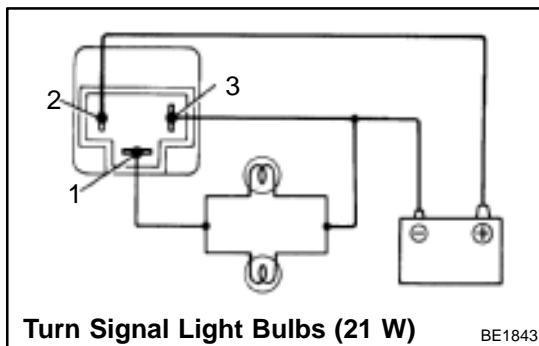

2. INSPECT TURN SIGNAL FLASHER OPERATION

- Connect the positive (+) lead from the battery to terminal 2 and the negative (–) lead to terminal 3.
- Connect the 2 turn signal light bulbs in parallel to each other to terminals 1 and 3, check that the bulbs flash.

HINT:

The turn signal lights should flash 60 to 120 times per minute. If one of the front or rear turn signal lights has an open circuit, the number of flashes will be more than 140 per minute. If operation is not as specified, replace the flasher.

3. INSPECT HAZARD WARNING SWITCH CONTINUITY

Switch position	Tester connection	Specified condition
Switch OFF	7 – 10	Continuity
Switch ON	5 – 6 – 9 7 – 8	Continuity
Illumination circuit	2 – 3	Continuity

If continuity is not as specified, replace the switch.

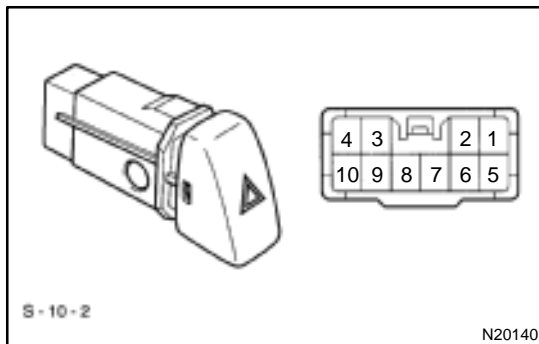

INTERIOR LIGHT SYSTEM LOCATION

BE0AA-03

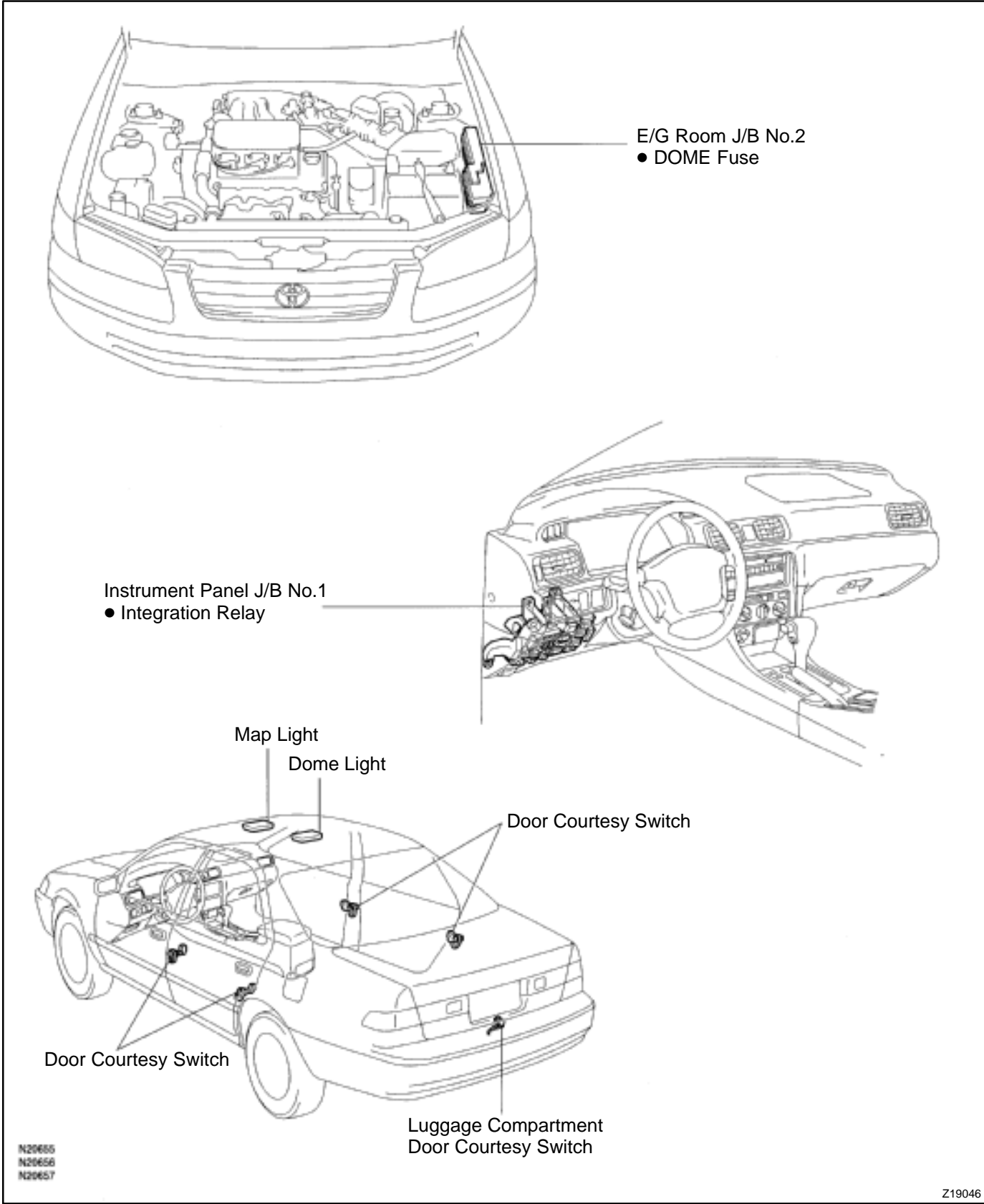

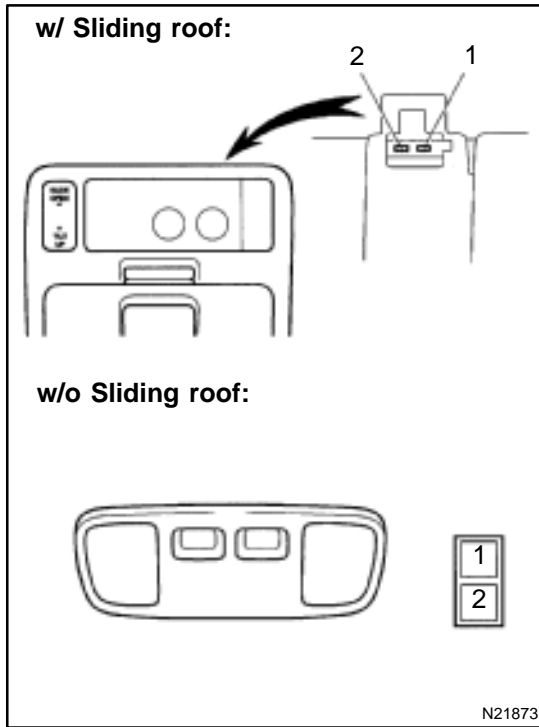

INSPECTION

1. INSPECT MAP LIGHT SWITCH CONTINUITY

Switch position	Tester connection	Specified condition
OFF	-	No continuity
ON	1 - 2	Continuity

If continuity is not as specified, replace the light assembly or bulb.

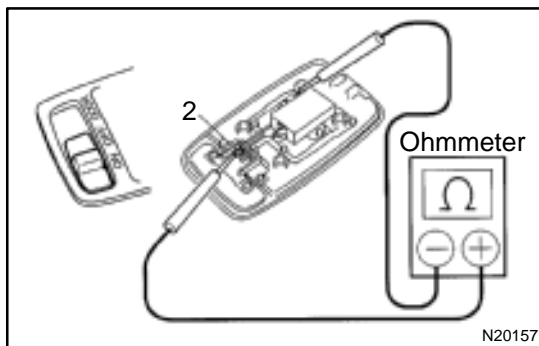

2. INSPECT DOME LAMP SWITCH

- (a) Disconnect the connector from the dome lamp.
- (b) Turn the dome lamp switch ON, check that continuity exists between terminal 2 and body ground.

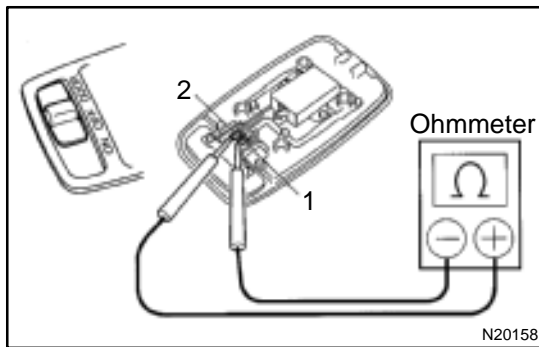

- (c) Turn the dome lamp switch DOOR, check that there is continuity exists between terminal 1 and 2.
- If operation is not as specified, replace the switch.

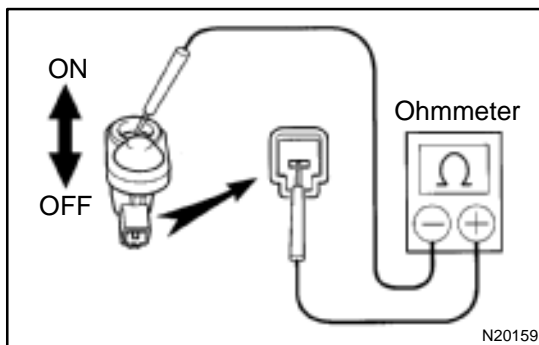

3. INSPECT DOOR COURTESY SWITCH CONTINUITY

- (a) Check that continuity exists between terminal and the switch body with the switch ON (switch pin released: opened door).
- (b) Check that no continuity exists between terminal and the switch body with the switch OFF (switch pin pushed in: closed doors).

If operation is not as specified, replace the switch.

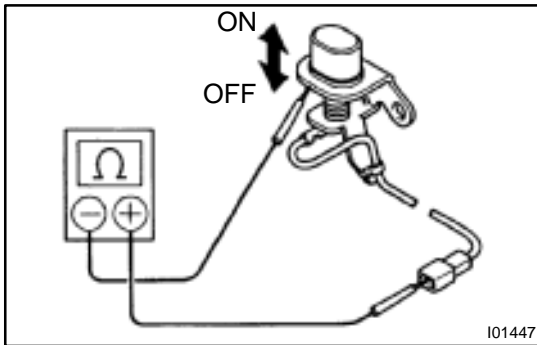

4. INSPECT LUGGAGE COMPARTMENT DOOR COURTESY SWITCH CONTINUITY

- (a) Check that continuity exists between terminal and switch body with the switch ON (switch pin released: opened door).
- (b) Check that no continuity exists between the terminal and switch body with the switch OFF (switch pin pushed in: closed door).

If operation is not as specified, replace the switch.

5. INSPECT ILLUMINATED ENTRY SYSTEM (See Integration relay circuit on page BE-14)

BACK-UP LIGHT SYSTEM LOCATION

BE0AC-02

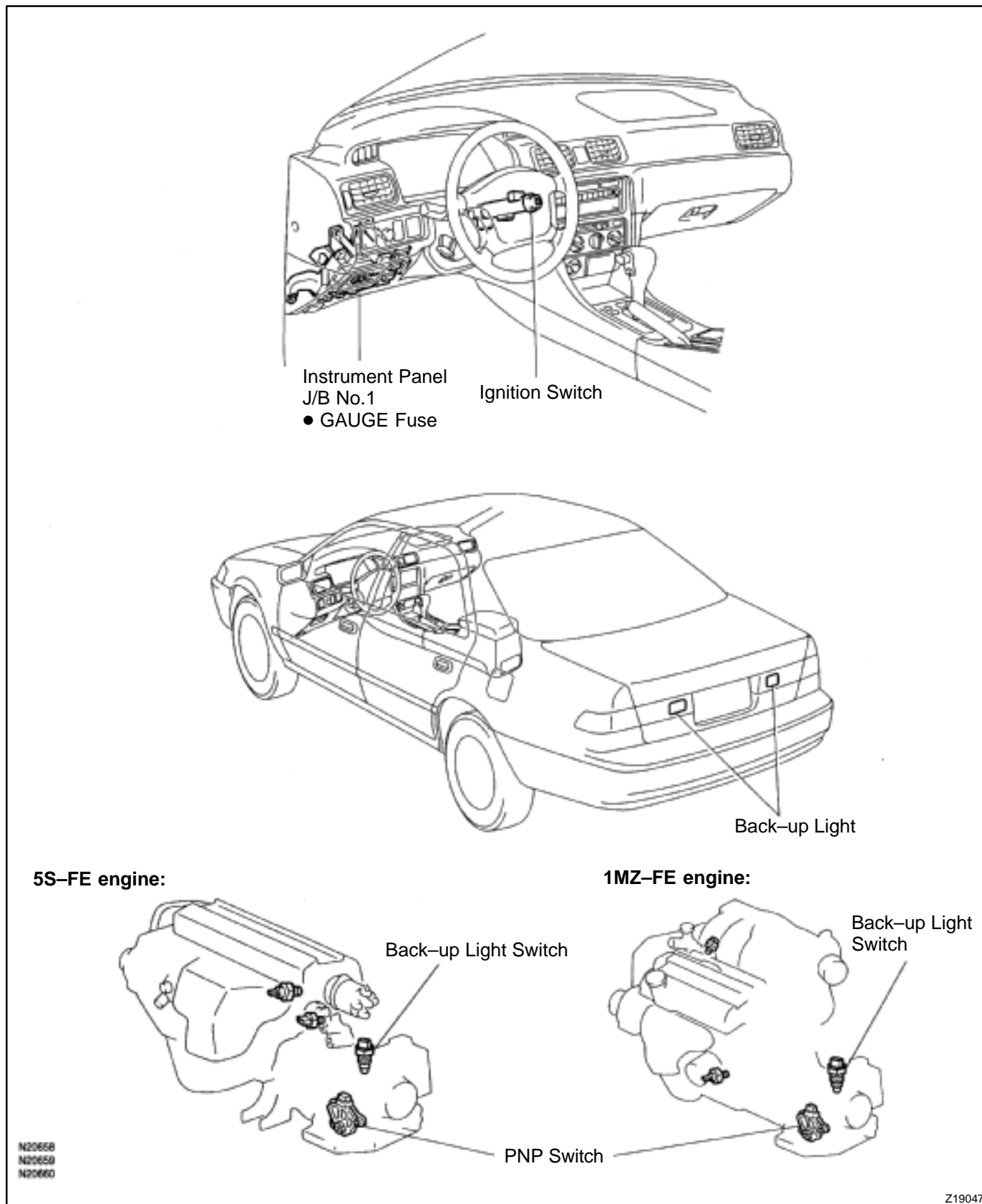

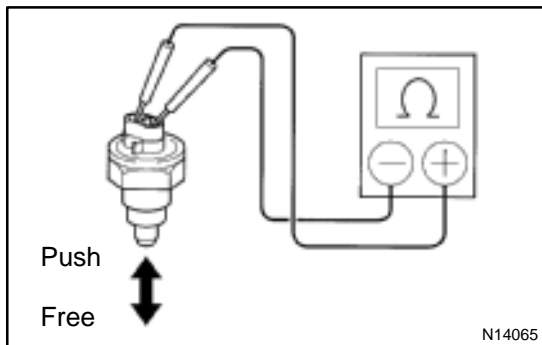

INSPECTION

INSPECT BACK-UP LIGHT SWITCH CONTINUITY

Condition	Tester connection	Specified condition
Free	-	No continuity
Push	1 - 2	Continuity

If continuity is not as specified, replace the switch.

STOP LIGHT SYSTEM LOCATION

BE0AE-02

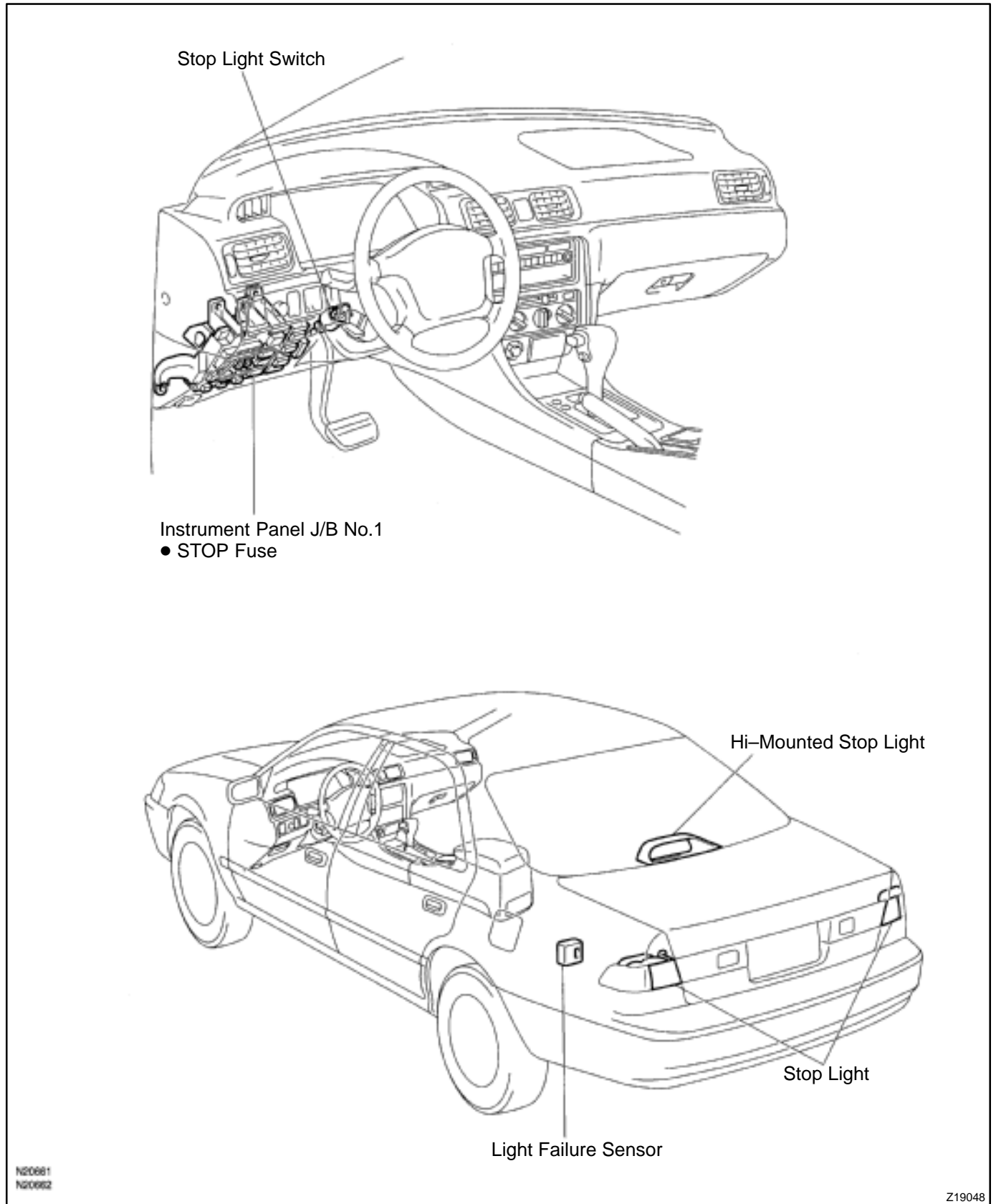

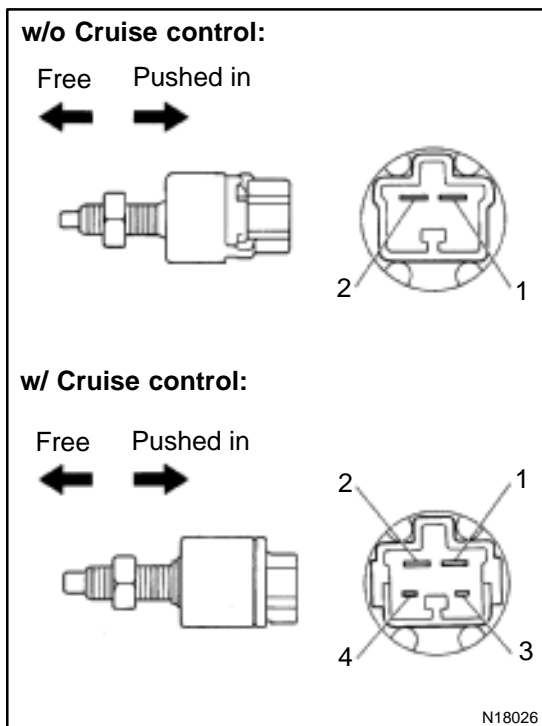

INSPECTION

1. w/o Cruise control: INSPECT STOP LIGHT SWITCH CONTINUITY

Switch position	Tester connection	Specified condition
Switch pin free	1 - 2	Continuity
Switch pin pushed in	1 - 2	No continuity

If continuity is not as specified, replace the switch.

2. w/ Cruise control: INSPECT STOP LIGHT SWITCH CONTINUITY

Switch position	Tester connection	Specified condition
Switch pin free	1 - 2	Continuity
Switch pin pushed in	1 - 2	No continuity
Switch pin free	3 - 4	No continuity
Switch pin pushed in	3 - 4	Continuity

If continuity is not as specified, replace the switch.

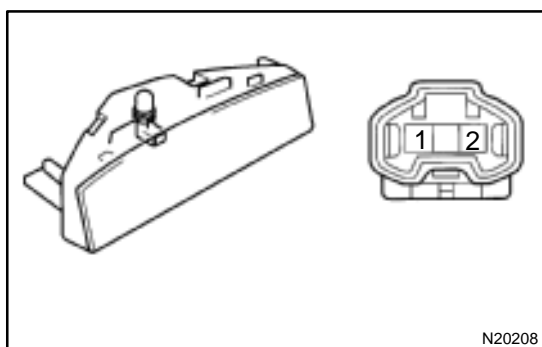

3. INSPECT HI-MOUNTED STOP LIGHT ASSEMBLY CONTINUITY

Using the ohmmeter, check that continuity exists between terminals.

If continuity is not as specified, replace the bulb or light assembly.

Wire harness side:

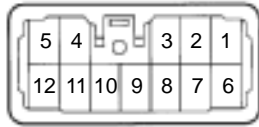

e-12-2-B

N20209

4. INSPECT LIGHT FAILURE RELAY CIRCUIT

Disconnect the connector from the relay and inspect the connector on the wire harness side, as shown.

Tester connection	Condition	Specified condition
1 – Ground	Constant	Continuity*
2 – Ground	Constant	Continuity*
9 – Ground	Constant	Continuity*
11 – Ground	Constant	Continuity
3 – Ground	Light control switch OFF	No voltage
3 – Ground	Light control switch TAIL or HEAD	Battery positive voltage
4 – Ground	Ignition switch LOCK or ACC	No voltage
4 – Ground	Ignition switch ON	Battery positive voltage
7 – Ground	Stop light switch OFF	No voltage
7 – Ground	Stop light switch ON	Battery positive voltage
8 – Ground	Ignition switch LOCK or ACC	No voltage
8 – Ground	Ignition switch ON	Battery positive voltage

*: There is resistance because this circuit is grounded through the bulb.

If the circuit is as specified, replace the relay.

If the circuit is not as specified, inspect the circuits connected to other parts.

WIPER AND WASHER SYSTEM LOCATION

BE0AG-03

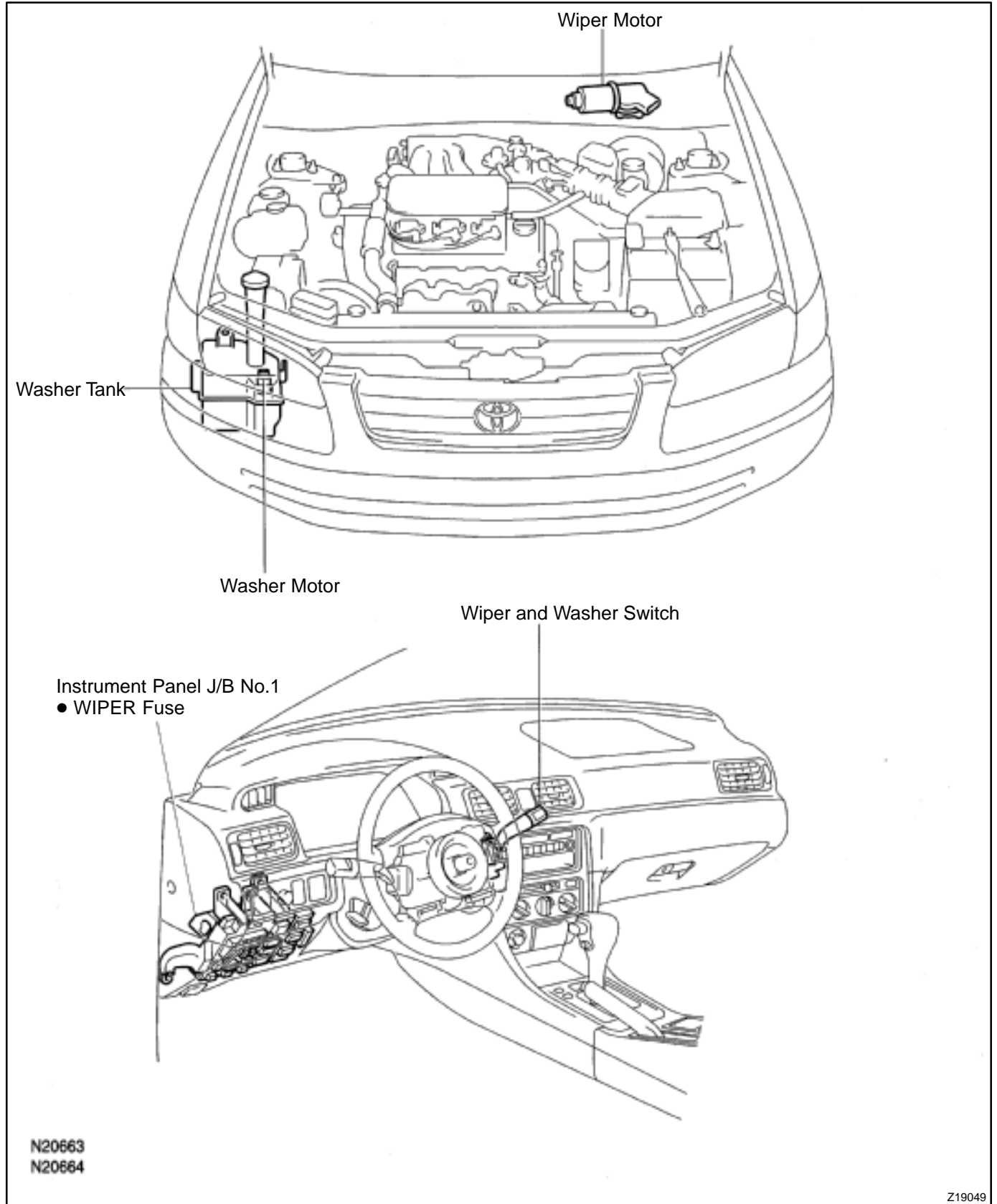

N20663
N20664

Z19049

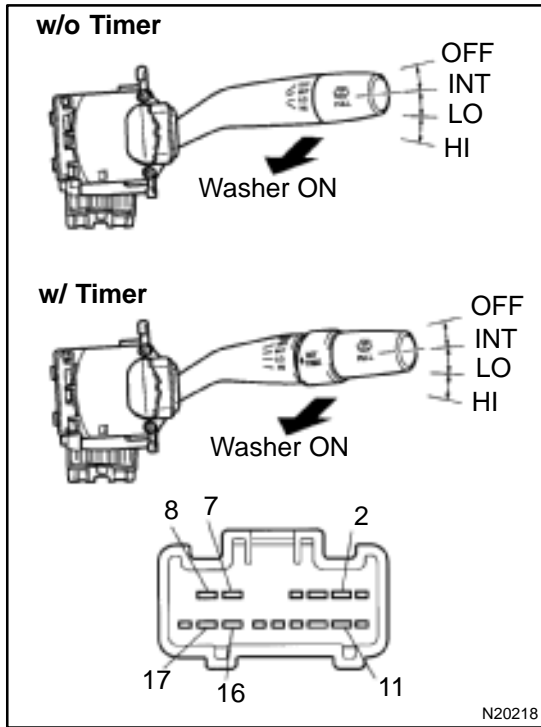

INSPECTION

1. INSPECT FRONT WIPER AND WASHER SWITCH CONTINUITY

Switch position	Tester connection	Specified condition
OFF	7 - 16	Continuity
INT	7 - 16	Continuity
LO	7 - 17	Continuity
HI	8 - 17	Continuity
Washer ON	2 - 11	Continuity

If continuity is not as specified, replace the switch.

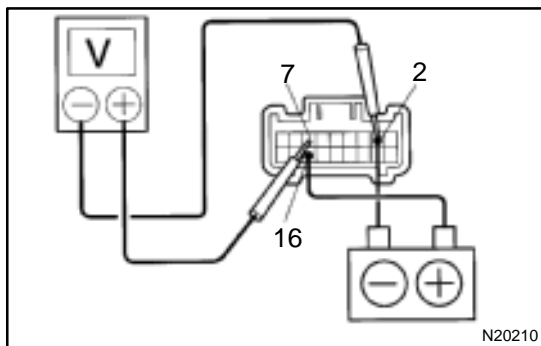

2. INSPECT INTERMITTENT OPERATION

- (a) Turn the wiper switch to INT position.
- (b) Turn the intermittent time control switch to FAST position.
- (c) Connect the positive (+) lead from the battery to terminal 16 and the negative (-) lead to terminal 2.
- (d) Connect the positive (+) lead from the voltmeter to terminal 7 and the negative (-) lead to terminal 2, check that the meter needle indicates battery positive voltage.
- (e) After connecting terminal 16 to terminal 17, connect it to terminal 2, check the voltage rises from 0 volts to battery positive voltage within the time, as shown in the table.

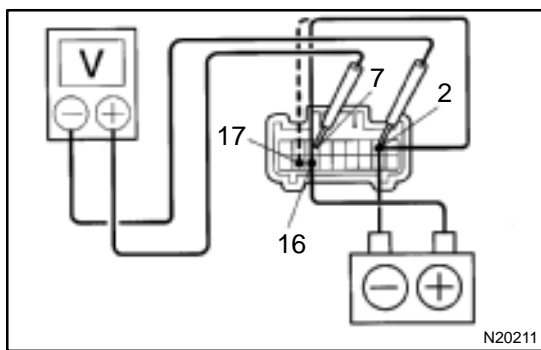

INT time control switch position	Voltage
FAST	Approx. 2 sec.
SLOW	10.7 ± 5 sec.
Non variable type	3.3 ± 1 sec.

If operation is not as specified, replace the wiper and washer switch.

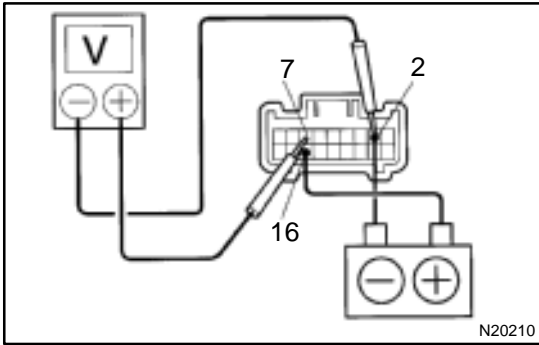

3. INSPECT WASHER LINKED OPERATION

- (a) Connect the positive (+) lead from the battery to terminal 16 and the negative (-) lead to terminal 2.
- (b) Connect the positive (+) lead from the voltmeter to terminal 7 and the negative (-) lead to terminal 2.
- (c) Push in the washer switch, and check that the voltage changes as shown in the chart.

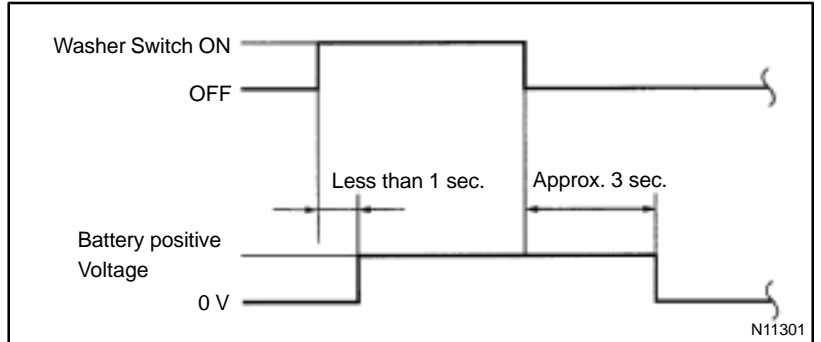

If operation is not as specified, replace the wiper and washer switch.

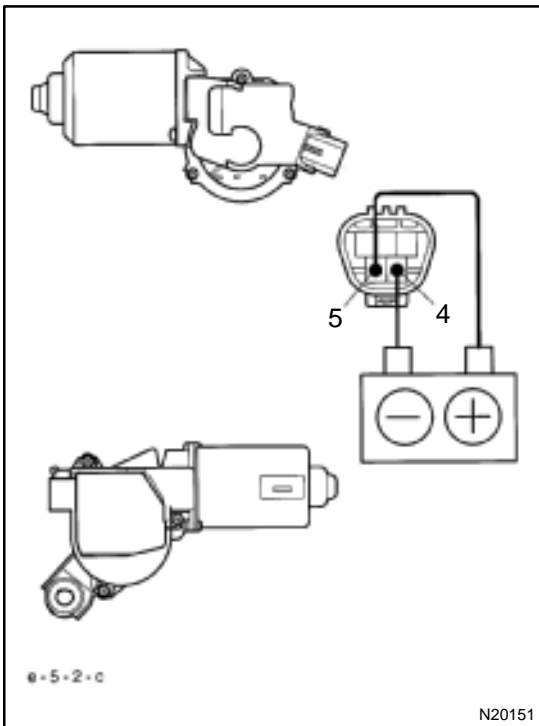

4. Low speed:

INSPECT FRONT WIPER MOTOR OPERATION

Connect the positive (+) lead from the battery to terminal 5 and the negative (-) lead to terminal 4, check that the motor operates at low speed.

If operation is not as specified, replace the motor.

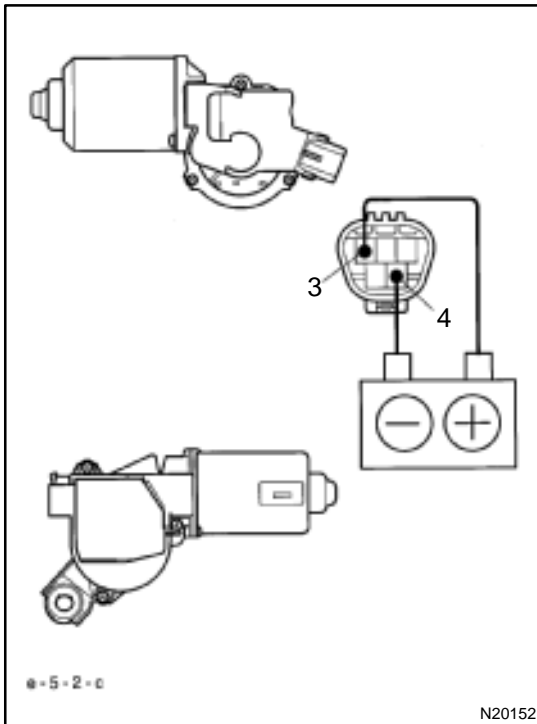

5. High speed:

INSPECT FRONT WIPER MOTOR OPERATION

Connect the positive (+) lead from the battery to terminal 3 and the negative (-) lead to terminal 4, check that the motor operates at high speed.

If operation is not as specified, replace the motor.

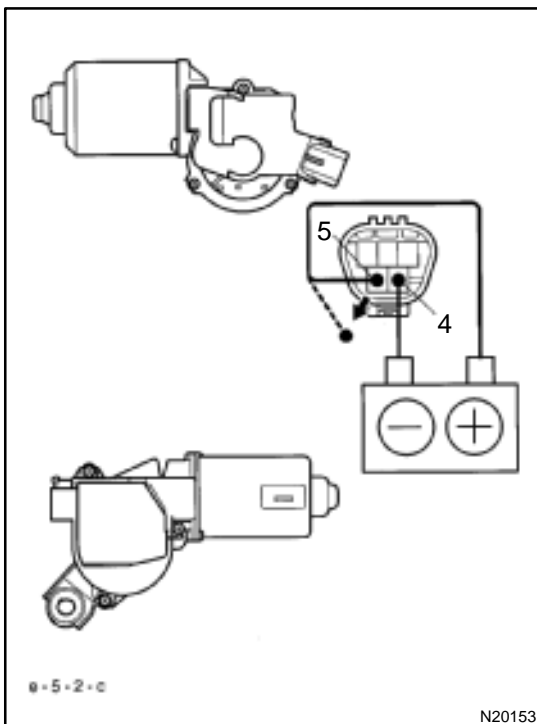

6. Stopping in stop position:

INSPECT FRONT WIPER MOTOR OPERATION

- (a) Operate the motor at low speed and stop the motor operation anywhere except in the stop position by disconnecting positive (+) lead from terminal 5.

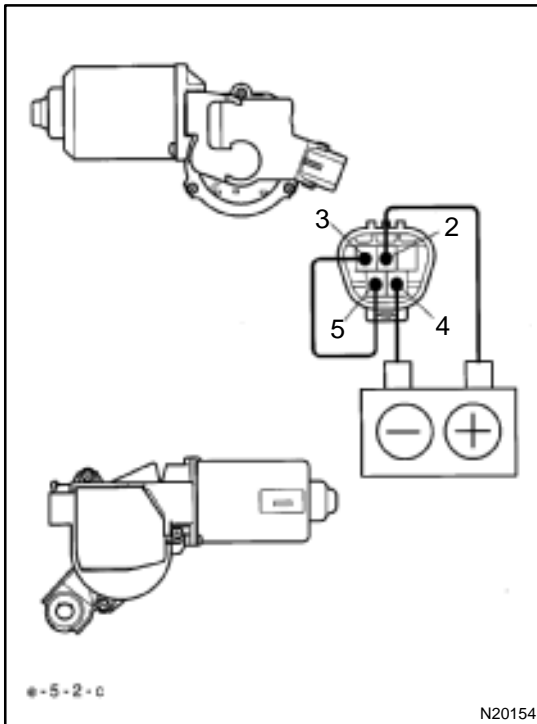

- (b) Connect terminals 3 and 5.
 (c) Connect the positive (+) lead from the battery to terminal 2 and negative (-) lead to terminal 4, check that the motor stops running in the stop position after the motor operates again.

If operation is not as specified, replace the motor.

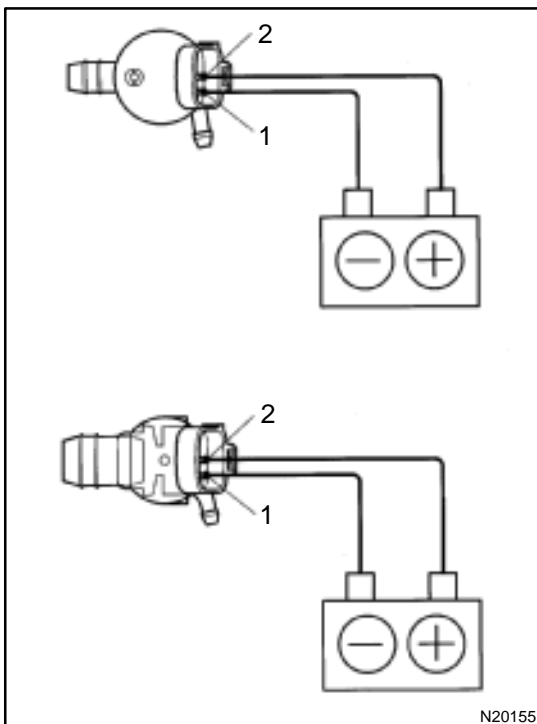

7. INSPECT WASHER MOTOR OPERATION

Connect the positive (+) lead from the battery to terminal 2 and the negative (-) lead to terminal 1, check that the motor operates.

NOTICE:

These tests must be performed quickly (within 20 seconds) to prevent the coil from burning out.

If operation is not as specified, replace the motor.

COMBINATION METER LOCATION

BE0A1-03

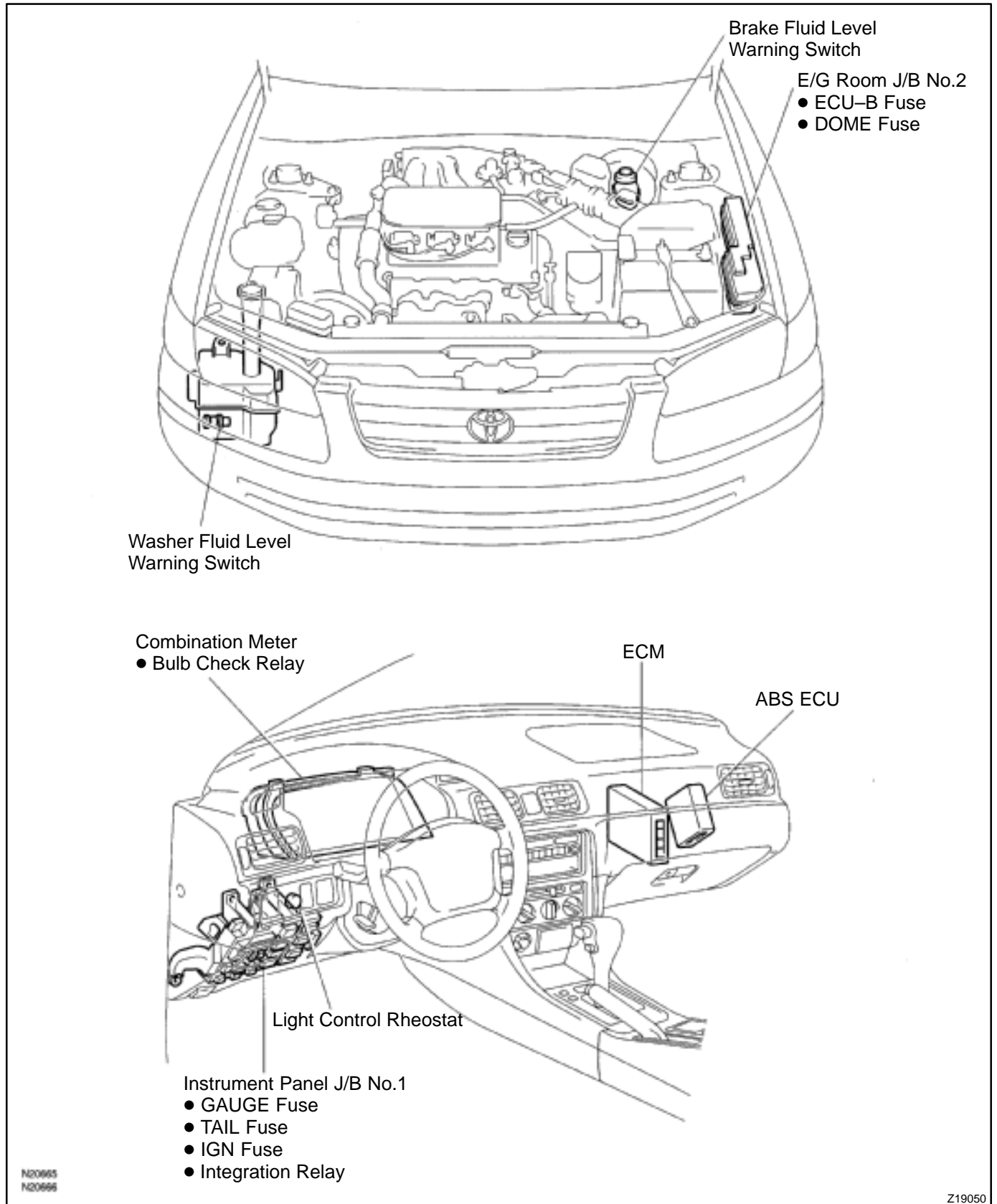

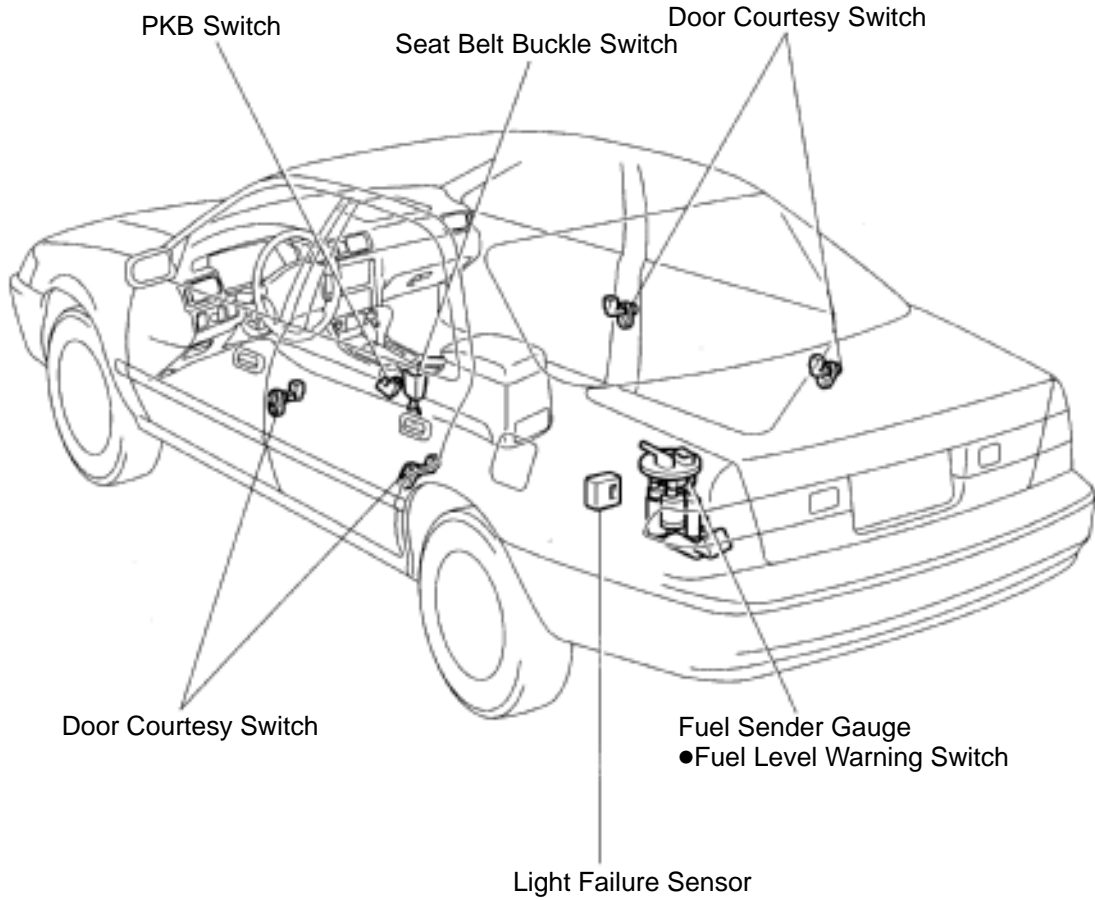

5S-FE engine:

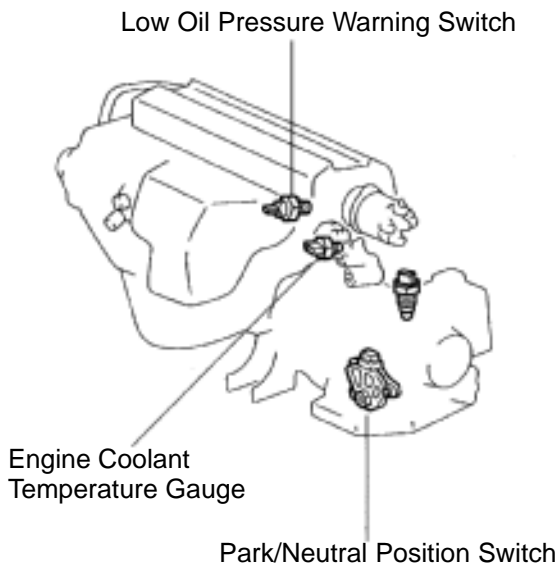

1MZ-FE engine:

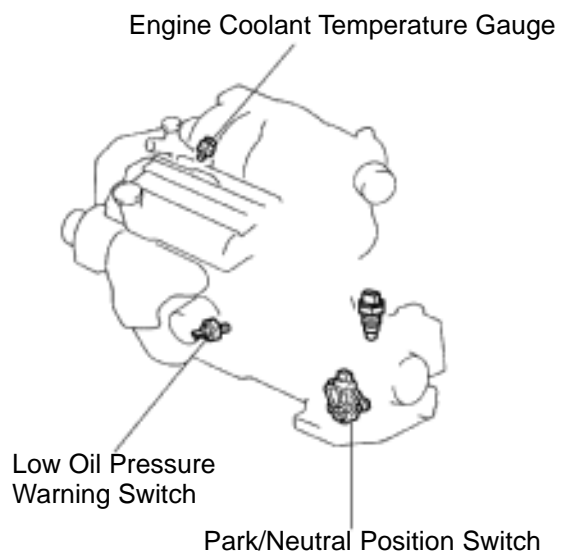

N20867
N20860

Z19055

CIRCUIT

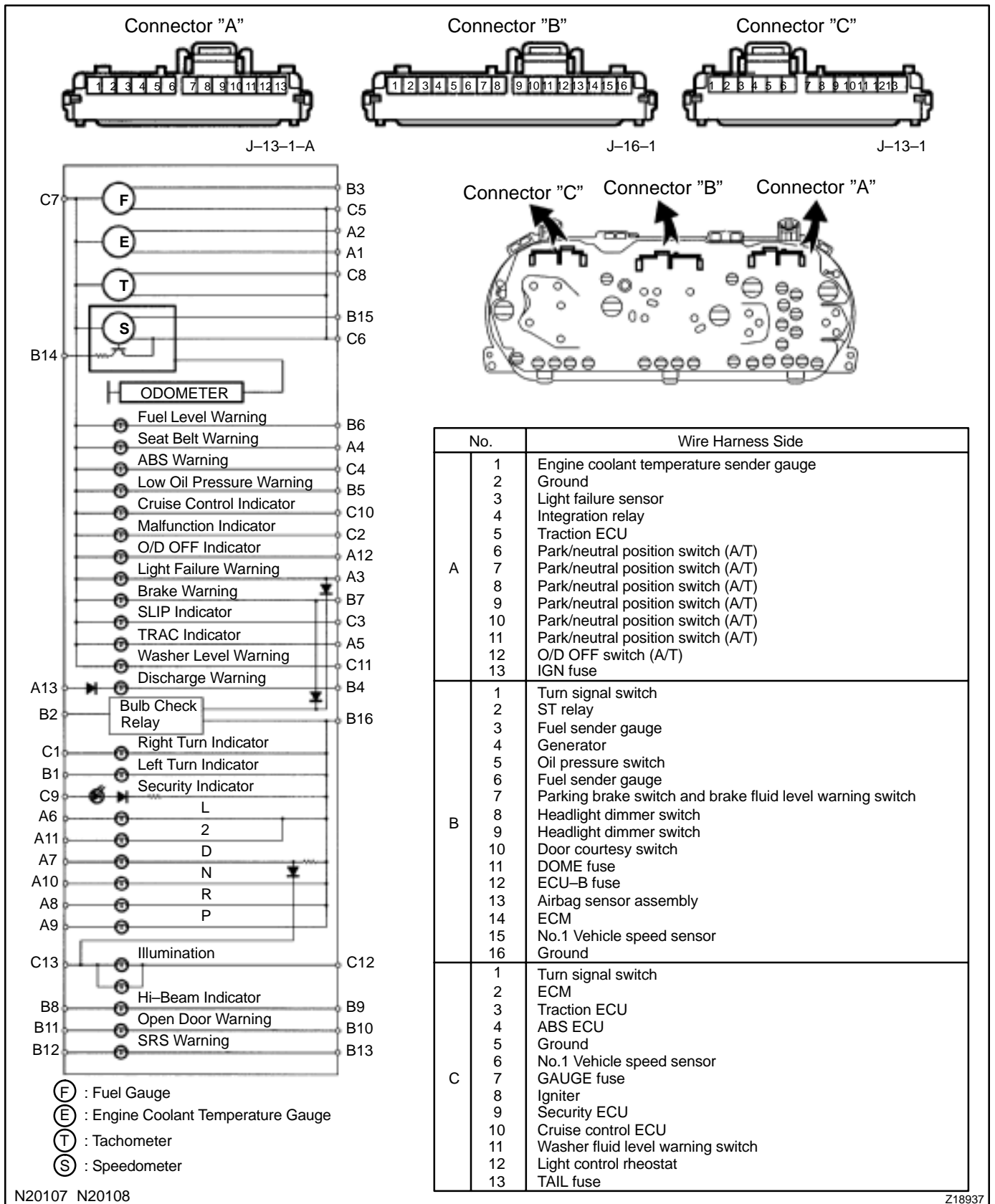

N20107 N20108

Z18937

INSPECTION

1. INSPECT SPEEDOMETER ON-VEHICLE

Using a speedometer tester, inspect the speedometer for allowable indication error and check the operation of the odometer.

HINT:

Tire wear and tire over or under inflation will increase the indication error.

If error is excessive, replace the speedometer.

USA (mph)		CANADA (km/h)	
Standard indication	Allowable range	Standard indication	Allowable range
20	18 – 24	20	17 – 24
40	38 – 44	40	38 – 46
60	56 – 66	60	57.5 – 67
80	78 – 88	80	77 – 88
100	98 – 110	100	96 – 109
120	118 – 132	120	115 – 130
		140	134 – 151.5
		160	153 – 173

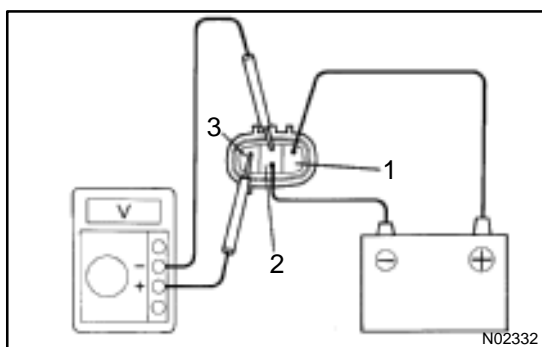

2. INSPECT VEHICLE SPEED SENSOR OPERATION

- Connect the positive (+) lead from the battery to terminal 1 and negative (–) lead to terminal 2.
- Connect the positive (+) lead from the tester to terminal 3 and the negative (–) lead to terminal 2.
- Rotate the shaft.
- Check that there is voltage change from approx. 0 V to 11 V or more between terminals 2 and 3.

HINT:

The voltage change should be performed 4 times for every revolution of the speed sensor shaft.

If operation is not as specified, replace the sensor.

3. INSPECT TACHOMETER ON-VEHICLE

- Connect a tune-up test tachometer, and start the engine.

NOTICE:

- Reversing the connection of the tachometer will damage the transistors and diodes inside.
- When removing or installing the tachometer, be careful not to drop or subject it to heavy shocks.

(b) Compare the tester with tachometer indications.

DC 13.5 V 25°C at (77 °F)

Standard indication	Allowable range
700	630 – 770
1,000	900 – 1,100
2,000	1,850 – 2,150
3,000	2,800 – 3,200
4,000	3,800 – 4,200
5,000	4,800 – 5,200
6,000	5,750 – 6,250
7,000	6,700 – 7,300

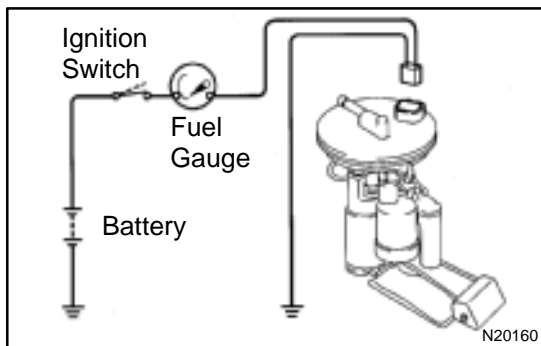

4. INSPECT FUEL RECEIVER GAUGE OPERATION

- (a) Disconnect the connector from the sender gauge.
- (b) Turn the ignition switch ON, check that the receiver gauge needle indicates EMPTY.

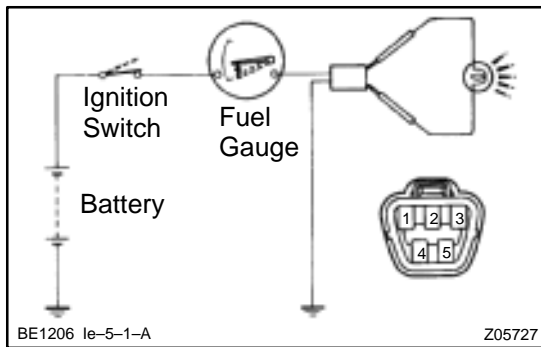

- (c) Connect terminals 2 and 3 on the wire harness side connector through a 3.4-W test bulb.
- (d) Turn the ignition switch ON, check that the bulb lights up and the receiver gauge needle moves towards the full side.

HINT:

Because of the silicon oil in the gauge, it will take a short time for needle to stabilize.

If operation is not as specified, inspect the receiver gauge resistance.

5. INSPECT FUEL RECEIVER GAUGE RESISTANCE

Measure the resistance between terminals.

Tester connection	Resistance (Ω)
A – B	Approx. 126.2
A – C	Approx. 280.5
B – C	Approx. 154.3

If resistance value is not as specified, replace the receiver gauge.

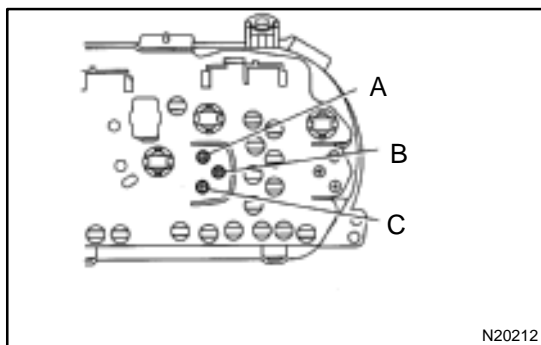

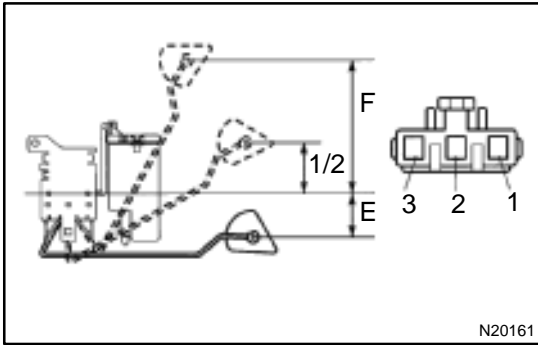

6. INSPECT FUEL SENDER GAUGE RESISTANCE

Measure the resistance between terminals 2 and 3 for each float position.

Float position mm (in.)	Resistance (Ω)
F: Approx. -91.1 (-3.587)	Approx. 3.0
1/2: Approx. -34.2 (-1.346)	Approx. 31.7
E: Approx. 30.8 (1.213)	Approx. 110.0

If resistance value is not as specified, replace the sender gauge.

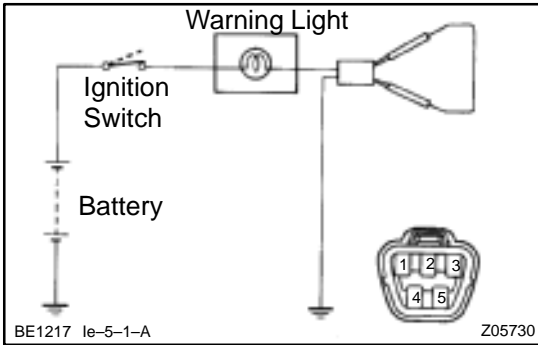

7. INSPECT FUEL LEVEL WARNING LIGHT

- (a) Disconnect the connector from the sender gauge.
- (b) Connect terminals 1 and 3 on the wire harness side connector.
- (c) Turn the ignition switch ON, check that the warning light lights up.

If the warning light does not light up, test the bulb or inspect wire harness.

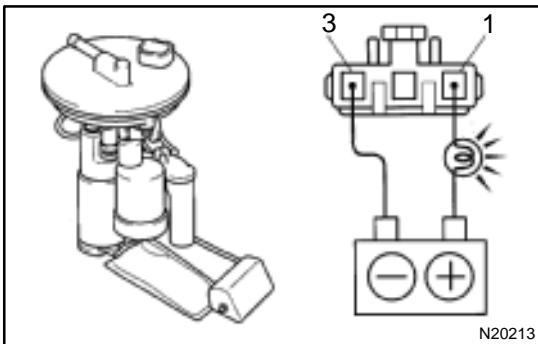

8. INSPECT FUEL LEVEL WARNING SWITCH

- (a) Apply battery positive voltage between terminals 1 and 3 through a 3.4-W test bulb, check that the bulb lights up.

HINT:

It takes a short time for the bulb to light up.

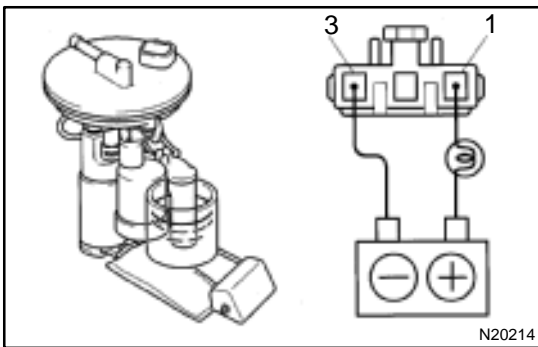

- (b) Submerge the switch in fuel, check that the bulb goes out. If operation is not as specified, replace the sender gauge.

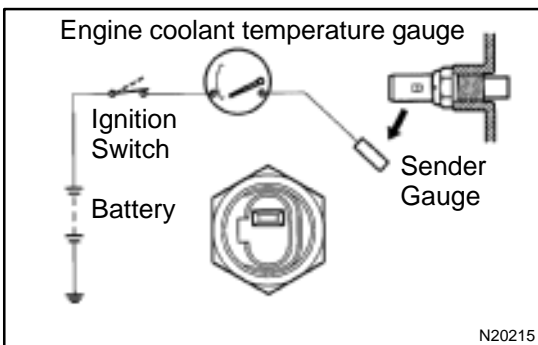

9. INSPECT ENGINE COOLANT TEMPERATURE RECEIVER GAUGE OPERATION

- (a) Disconnect the connector from the sender gauge.
- (b) Turn the ignition switch ON and check that the receiver gauge needle indicates COOL.

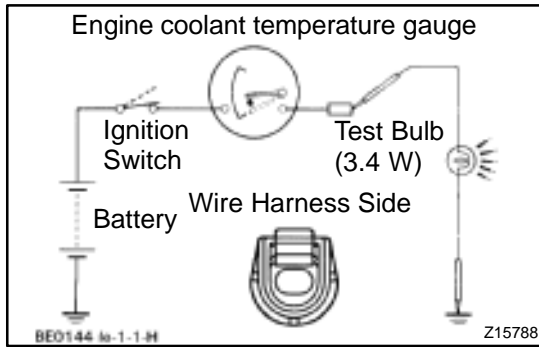

- (c) Ground terminal on the wire harness side connector through a 3.4-W test bulb.
 - (d) Turn the ignition switch ON, and check that the bulb lights up and the receiver gauge needle moves to the hot side.
- If operation is as specified, replace the sender gauge. Then, recheck the system.
- If operation is not as specified, measure the receiver gauge resistance.

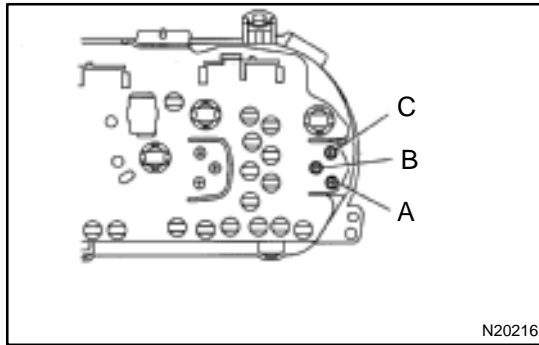

10. INSPECT ENGINE COOLANT TEMPERATURE RECEIVER GAUGE RESISTANCE

Measure the resistance between terminals.

Tester connection	Resistance (Ω) *
A – B	Approx. 175.7
A – C	Approx. 54.0
B – C	Approx. 229.7

*: This circuit includes the diode.

HINT:

Connect the test leads so that the current from the ohmmeter can flow according to the above order.

If resistance value is not as specified, replace the receiver gauge.

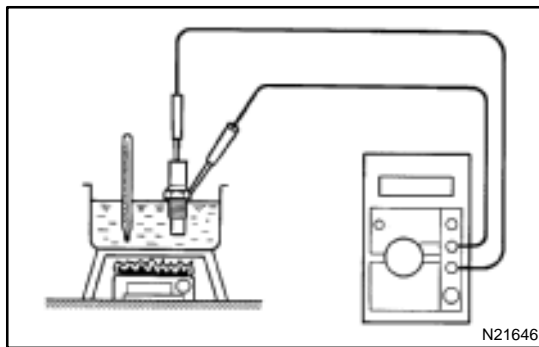

11. INSPECT ENGINE COOLANT TEMPERATURE SENDER GAUGE RESISTANCE

Measure the resistance between the terminal and gauge body.

Temperature °C (°F)	Resistance (Ω)
50 (122.0)	274
120 (248.0)	26.4

If resistance value is not as specified, replace the engine coolant temperature sender gauge.

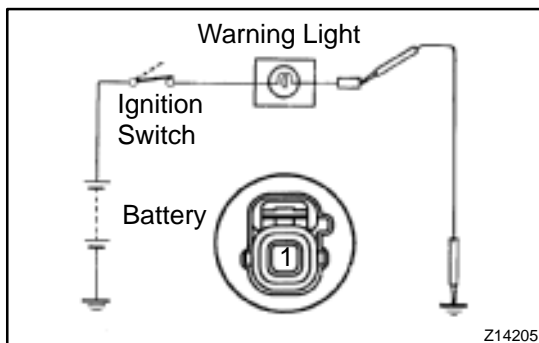

12. INSPECT LOW OIL PRESSURE WARNING LIGHT

- (a) Disconnect the connector from the warning switch and ground terminal on the wire harness side connector.
 - (b) Turn the ignition switch ON and check that the warning light lights up.
- If the warning light does not light up, test the bulb.

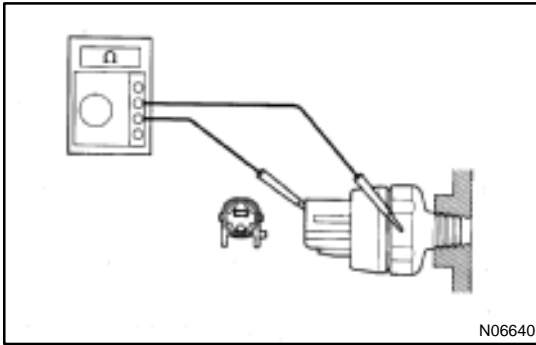
**13. INSPECT LOW OIL PRESSURE SWITCH**

- Disconnect the connector from the switch.
- Check that continuity exists between terminal and ground with the engine stopped.
- Check that no continuity exists between terminal and ground with the engine running.

HINT:

Oil pressure should be over 24.5 kPa (0.25 kgf/cm², 3.55 psi). If operation is not as specified, replace the switch.

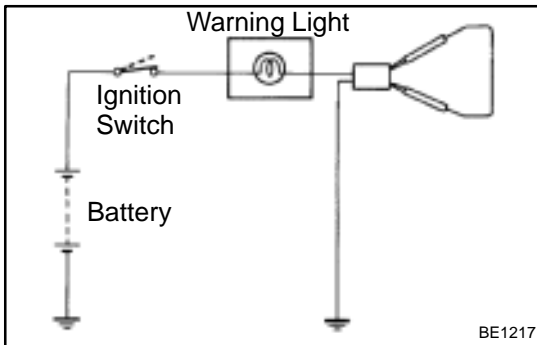
**14. INSPECT BRAKE SYSTEM WARNING LIGHT**

- Disconnect the connector from the brake fluid warning switch.
- Release the parking brake pedal.
- Connect the terminals on the wire harness side of the level warning switch connector.
- Start the engine, check that the warning light lights up. If the warning light does not light up, test the bulb or wire harness.

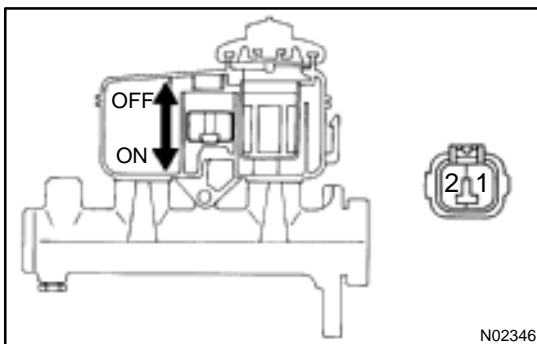
**15. INSPECT BRAKE FLUID LEVEL WARNING SWITCH**

- Remove the reservoir tank cap and strainer.
 - Disconnect the connector.
 - Check that no continuity exists between the terminals with the switch OFF (float up).
 - Use syphon, etc. to take fluid out of the reservoir tank.
 - Check that continuity exists between the terminals with the switch ON (float down).
 - Pour the fluid back in the reservoir tank.
- If operation is not as specified, replace the switch.

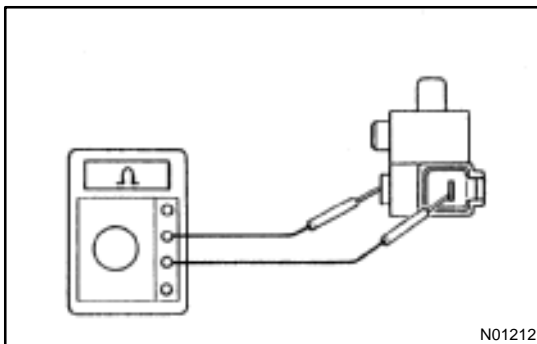
**16. INSPECT PARKING BRAKE SWITCH**

- Check that continuity exists between the terminal and switch body with the switch ON (switch pin released).
- Check that no continuity exists between the terminal and switch body with the switch OFF (switch pin pushed in).

If operation is not as specified, replace the switch or inspect ground point.

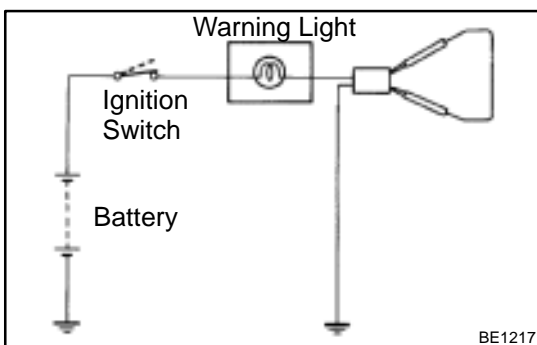
**17. INSPECT WASHER FLUID LEVEL WARNING LIGHT**

- Disconnect the connectors from the level warning switch and parking brake switch.
- Connect terminals on the wire harness side connector of the level warning switch connector.
- Remove the GAUGE fuse and turn the ignition switch ON, and check that the warning light comes on.

If the warning light does not light up, test the bulb.

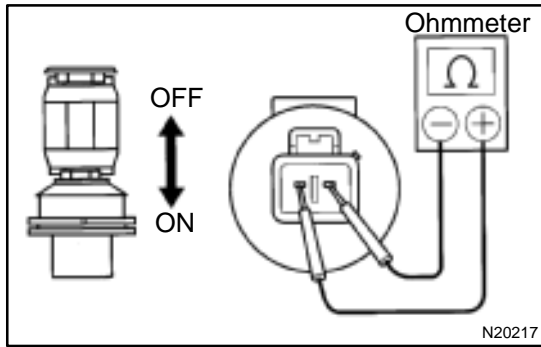

- 18. INSPECT WASHER FLUID LEVEL WARNING SWITCH**
- Check that no continuity exists between terminals with the switch OFF (float up).
 - Check that continuity exists between terminals with the switch ON (float down).
- If operation is not as specified, replace the switch.

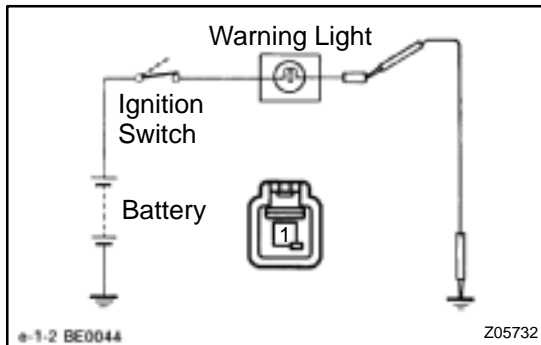

- 19. INSPECT OPEN DOOR WARNING LIGHT**
- Disconnect the connector from the door courtesy switch and ground terminal 1 on the wire harness side, and check that the warning light lights up.
- If the warning light does not light up, inspect the bulb or wire harness.

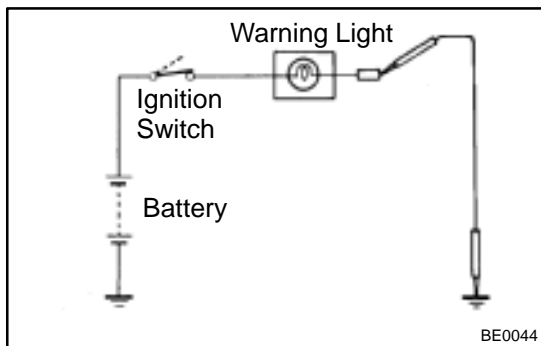

- 20. INSPECT SEAT BELT WARNING LIGHT**
- Remove the integration relay from the instrument panel junction block.
 - Ground terminal 2 on the integration relay with the connectors still connected.
 - Turn the ignition switch ON and check that the warning light lights up.
- If the warning light does not light up, inspect the bulb or wire harness.

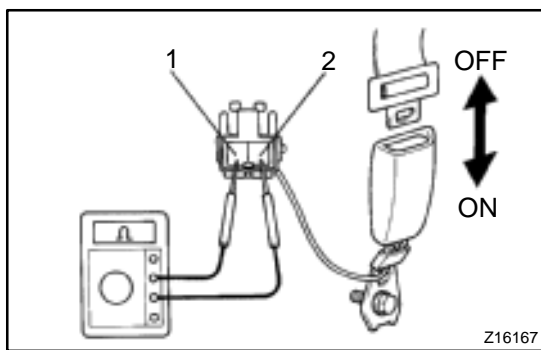

- 21. w/o Power seat:
INSPECT BUCKLE SWITCH CONTINUITY**
- Check that continuity exists between the terminals on the switch side connector with the switch ON (belt fastened).
 - Check that no continuity exists between the terminals on the switch side connector with the switch OFF (belt unfastened).
- If operation is not as specified, replace the seat belt inner belt.

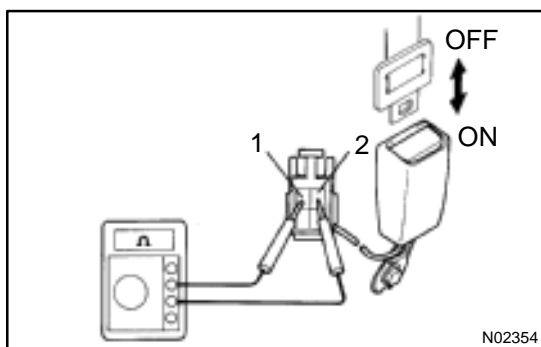

- 22. w/ Power seat:
INSPECT BUCKLE SWITCH CONTINUITY**
- Check that continuity exists between terminals 1 and 2 on the switch side connector with the switch ON (belt fastened).
 - Check that no continuity exists between terminals 1 and 2 on the switch side connector with the switch OFF (belt unfastened).
- If operation is not as specified, replace the seat belt inner belt.

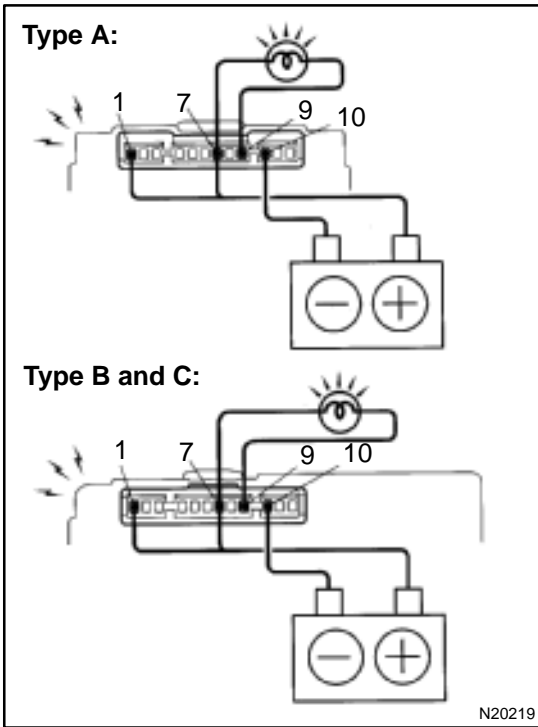

23. INSPECT INTEGRATION RELAY OF SEAT BELT WARNING SYSTEM OPERATION

- (a) Connect the positive (+) lead from the battery to terminals 1 and 7.
- (b) Connect the terminal 7 to terminal 9 through the 3.4-W test bulb.
- (c) Connect the negative (-) lead from the battery to terminal 10.
- (d) Check that the bulb lights and the buzzer sounds for 4 – 8 seconds.
- (e) Return to step (a) and operate the chime again.

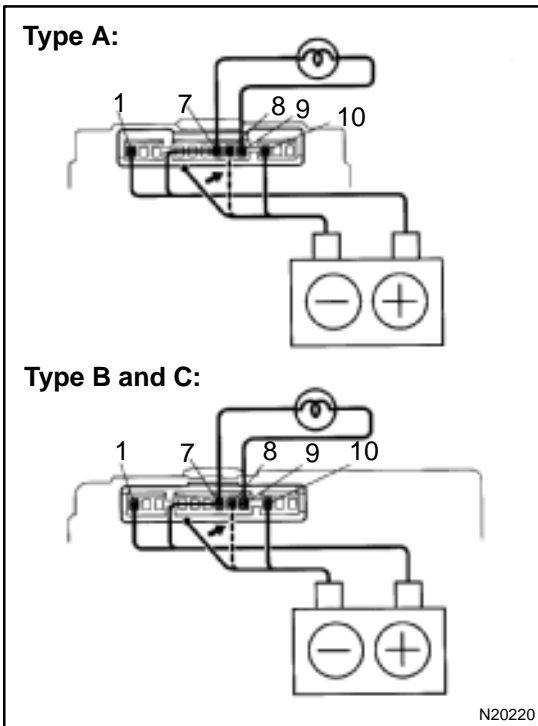

- (f) Connect the negative (-) lead from the battery to terminal 8.
- (g) Check that the buzzer stops sounding.

HINT:

Check the buzzer within a period of 4 to 8 seconds. If operation is not as specified, replace the relay.

24. INSPECT INTEGRATION RELAY CIRCUIT

See page [BE-14](#)

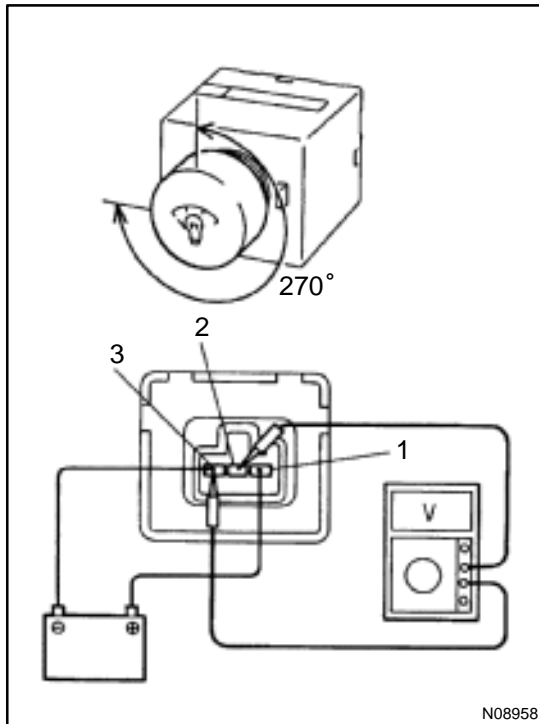
**25. INSPECT LIGHT CONTROL RHEOSTAT**

- (a) Connect the positive (+) lead from the battery to terminal 1 and negative lead (–) to terminal 3.
- (b) Connect the positive (+) lead from the voltmeter to terminal 2 and negative lead to terminal 3.
- (c) Turn the rheostat knob and check that the voltage changes.

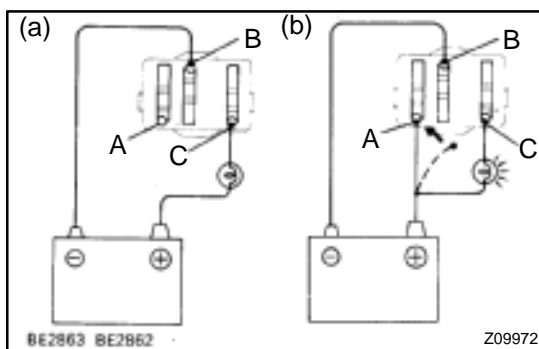
**26. INSPECT BULB CHECK RELAY OPERATION**

- (a) Connect the positive (+) lead from the battery to terminal C through a 1.4-W test bulb and the negative (–) lead to terminal B, check that the test bulb does not light up.
- (b) Connect the positive (+) lead from the battery to terminal A and check that the test bulb lights up.

If operation is not as specified, replace the relay.

DEFOGGER SYSTEM LOCATION

BE0AL-03

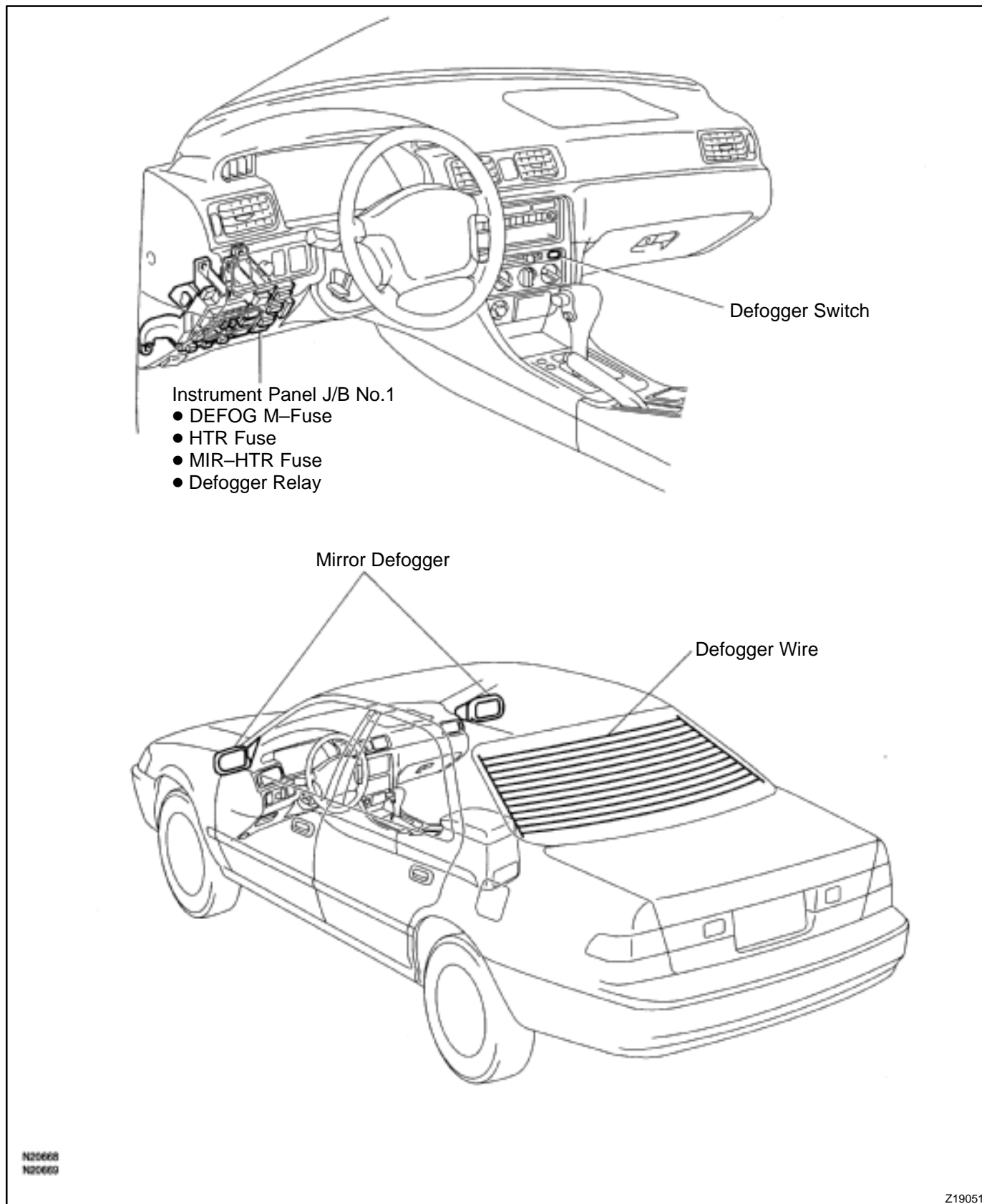

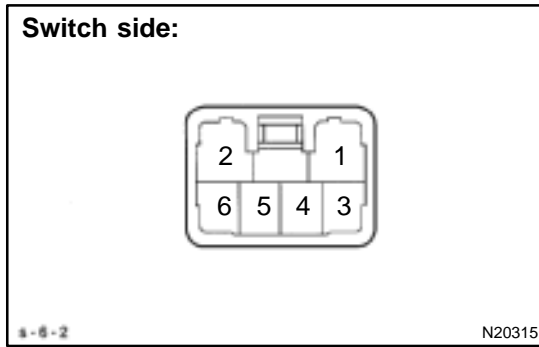

INSPECTION

1. INSPECT DEFOGGER SWITCH CONTINUITY

Check that is continuity exists between terminals 2 and 6. If continuity is not as specified, check the bulb.

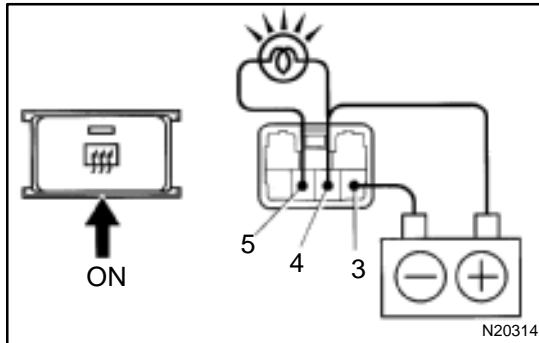

2. INSPECT DEFOGGER TIMER OPERATION

- Connect the positive (+) lead from the battery to terminal 4 and the negative (-) lead to terminal 3.
- Connect the positive (+) lead from the battery to terminal 5 through a 3.4-W tester bulb.
- Push the defogger switch ON, check that the indicator light and test bulb light up for 12 to 18 minutes, then the indicator light and test bulb light goes out.

If operation is not as specified, replace the switch.

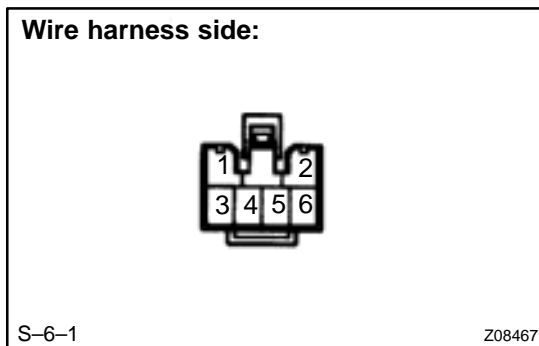

3. INSPECT DEFOGGER TIMER CIRCUIT

Disconnect the connector from the switch and inspect the connector on the wire harness side, as shown in the table.

Tester connection	Condition	Specified condition
3 - Ground	Constant	Continuity
4 - Ground	Ignition switch LOCK or ACC	No voltage
4 - Ground	Ignition switch ON	Battery positive voltage
5 - Ground	Ignition switch LOCK or ACC	No voltage
5 - Ground	Ignition switch ON	Battery positive voltage
-	Connect terminals 3 and 5.	Defogger system operation is normal

If the circuit is not as specified, replace the switch.

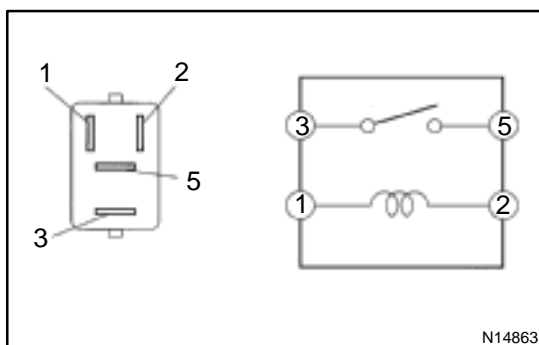

4. INSPECT DEFOGGER RELAY CONTINUITY

Condition	Tester connection	Specified condition
Constant	1 - 2	Continuity
Apply B+ between terminals 1 and 2.	3 - 5	Continuity

If continuity is not as specified, replace the relay.

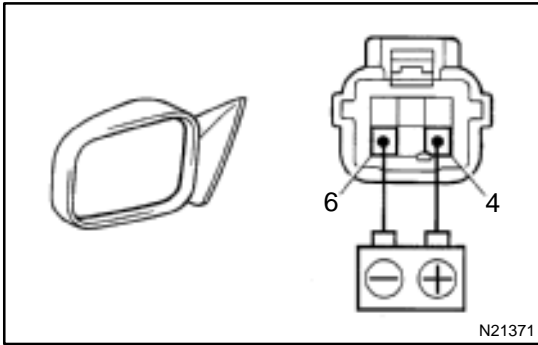

5. w/ Heater:

INSPECT MIRROR DEFOGGER

- (a) Connect the positive (+) lead from the battery to terminal 4 and the negative (-) lead to terminal 6.
- (b) Check that the mirror becomes warm.

HINT:

It takes short time for the mirror to become warm.

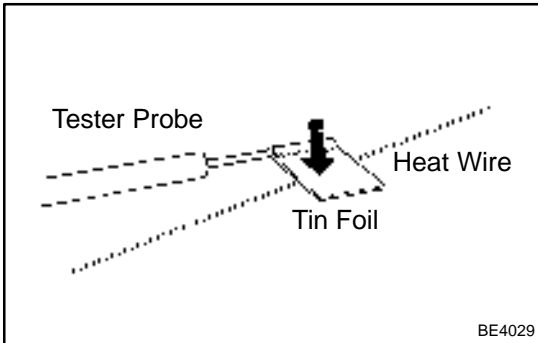

6. INSPECT DEFOGGER WIRE

NOTICE:

- When cleaning the glass, use a soft, dry cloth, and wipe the glass in the direction of the wire. Take care not to damage the wires.
- Do not use detergents or glass cleaners with abrasive ingredients.
- When measuring voltage, wind a piece of tin foil around the top of the negative probe and press the foil against the wire with your finger, as shown.

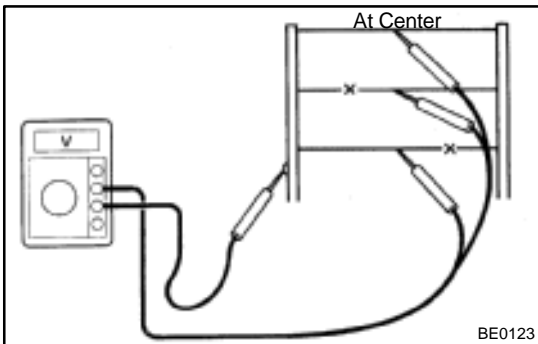

- (a) Turn the ignition switch ON.
- (b) Turn the defogger switch ON.
- (c) Inspect the voltage at the center of each heat wire, as shown.

Voltage	Criteria
Approx. 5V	Okay (No break in wire)
Approx. 10V or 0V	Broken wire

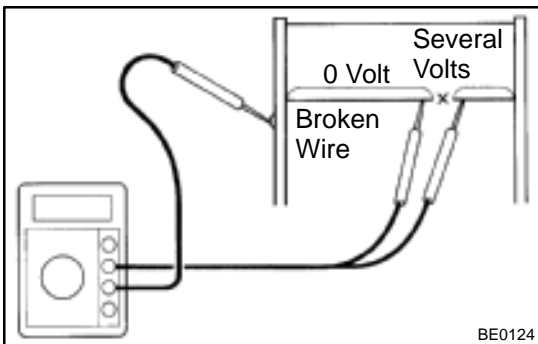

HINT:

If there is approximately 10 V, the wire is broken between the center of the wire and the positive (+) end. If there is no voltage, the wire is broken between the center of the wire and ground.

- (d) Place the voltmeter positive (+) lead against the defogger positive (+) terminal.
- (e) Place the voltmeter negative (-) lead with the foil strip against the heat wire at the positive (+) terminal end and slide it toward the negative (-) terminal end.
- (f) The point where the voltmeter deflects from zero to several V is the place where the heat wire is broken.

HINT:

If the heat wire is not broken, the voltmeter indicates 0 V at the positive (+) end of the heat wire but gradually increases to about 12 V as the meter probe is moved to the other end.

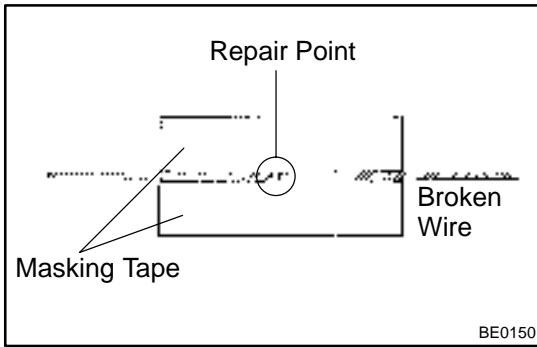

7. IF NECESSARY, REPAIR DEFOGGER WIRE

- (a) Clean the broken wire tips with grease, wax and silicone remover.
- (b) Place the masking tape along both sides of the wire to be repaired.
- (c) Thoroughly mix the repair agent (Dupont paste No. 4817).

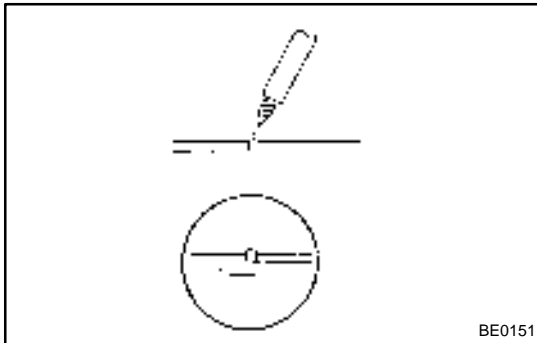

- (d) Thoroughly mix the repair agent (Dupont paste No. 4817 or equivalent).
- (e) Using a fine tip brush, apply a small amount to the wire.
- (f) After a few minutes, remove the masking tape.
- (g) Do not repair the defogger wire for at least 24 hours.

POWER WINDOW CONTROL SYSTEM LOCATION

BE0AN-03

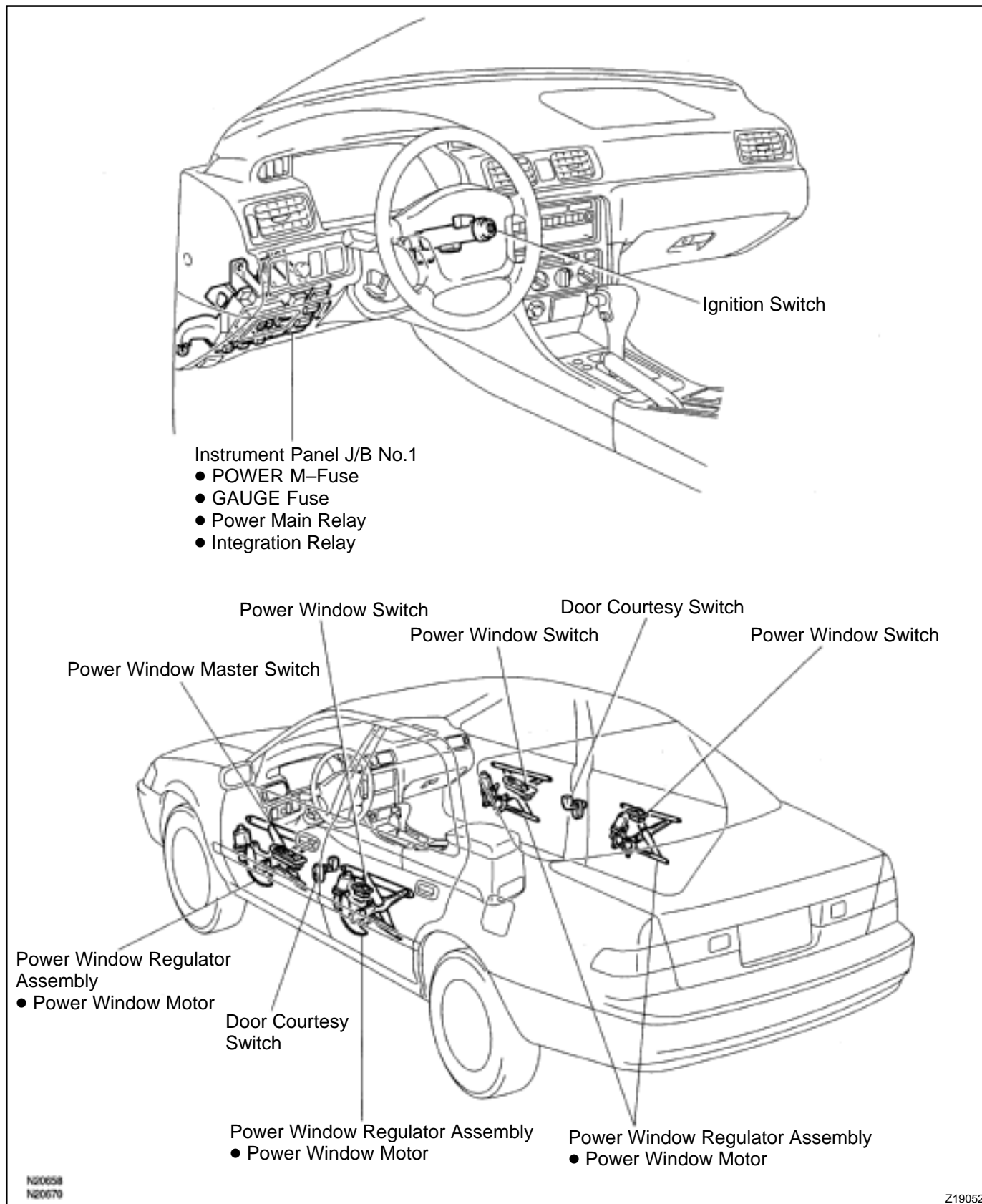

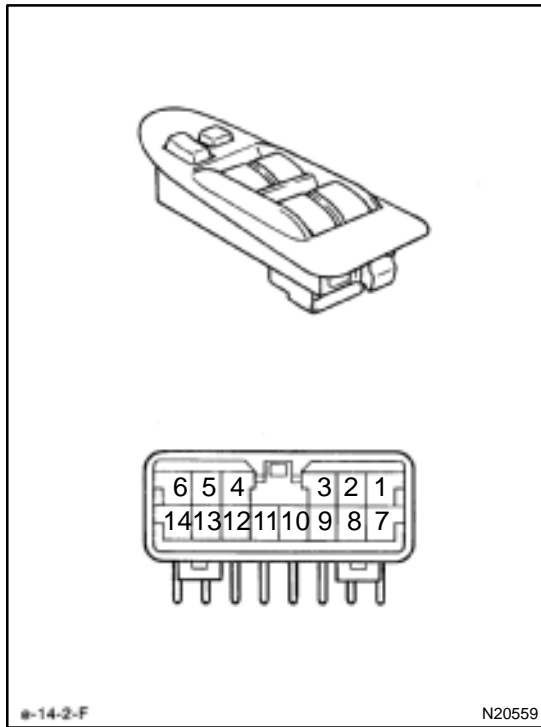

INSPECTION

1. INSPECT POWER WINDOW MASTER SWITCH CONTINUITY

(a) Inspect the front driver's switch.

Window unlock:

Switch position	Tester connection	Specified condition
UP	3 – 8 – 9	Continuity
	4 – 5 – 6	
OFF	3 – 4 – 5	Continuity
	4 – 5 – 6	
DOWN	6 – 8 – 9	Continuity
	3 – 4 – 5	

Window lock:

Switch position	Tester connection	Specified condition
UP	3 – 8 – 9	Continuity
	4 – 5 – 6	
OFF	3 – 4 – 5	Continuity
	4 – 5 – 6	
DOWN	6 – 8 – 9	Continuity
	3 – 4 – 5	

(b) Inspect the front passenger's switch.

Window unlock:

Switch position	Tester connection	Specified condition
UP	8 – 9 – 11	Continuity
	4 – 5 – 13	
OFF	4 – 5 – 11	Continuity
	4 – 5 – 13	
DOWN	8 – 9 – 13	Continuity
	4 – 5 – 11	

Window lock:

Switch position	Tester connection	Specified condition
UP	8 – 9 – 11	Continuity
OFF	11 – 13	Continuity
DOWN	8 – 9 – 13	Continuity

(c) Inspect the rear left switch.

Window unlock:

Switch position	Tester connection	Specified condition
UP	8 – 9 – 10	Continuity
	4 – 5 – 12	
OFF	4 – 5 – 10	Continuity
	4 – 5 – 12	
DOWN	8 – 9 – 12	Continuity
	4 – 5 – 10	

Window lock:

Switch position	Tester connection	Specified condition
UP	8 – 9 – 10	Continuity
OFF	10 – 12	Continuity
DOWN	8 – 9 – 12	Continuity

(d) Inspect the rear right switch.

Window unlock:

Switch position	Tester connection	Specified condition
UP	7 – 8 – 9 4 – 5 – 14	Continuity
OFF	4 – 5 – 7 4 – 5 – 14	Continuity
DOWN	8 – 9 – 14 4 – 5 – 7	Continuity

Window lock:

Switch position	Tester connection	Specified condition
UP	7 – 8 – 9	Continuity
OFF	7 – 14	Continuity
DOWN	8 – 9 – 14	Continuity

If continuity is not as specified, replace the master switch.

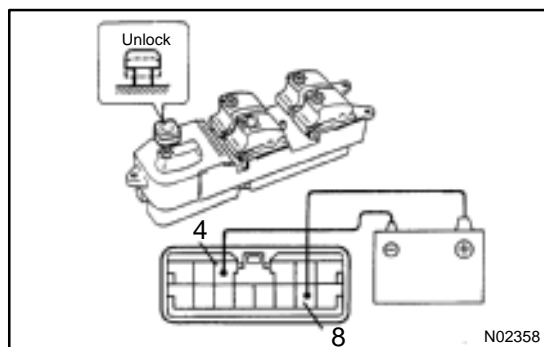
**2. INSPECT POWER WINDOW MASTER SWITCH ILLUMINATION**

- (a) Set the window lock switch to the unlock position.
- (b) Connect the positive (+) lead from the battery to terminal 8 and the negative (-) lead to terminal 4, and check that all the illuminations light up.

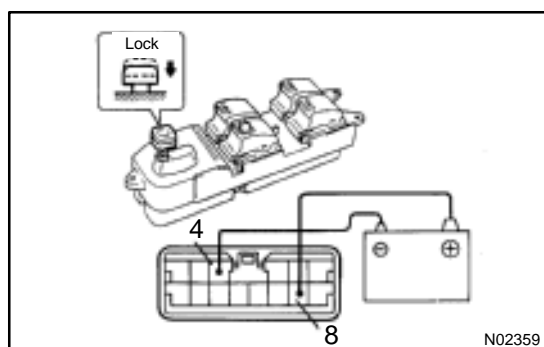

- (c) Set the window lock switch to the lock position, check that all the passenger's power window switch illuminations go out.

If operation is not as specified, replace the master switch.

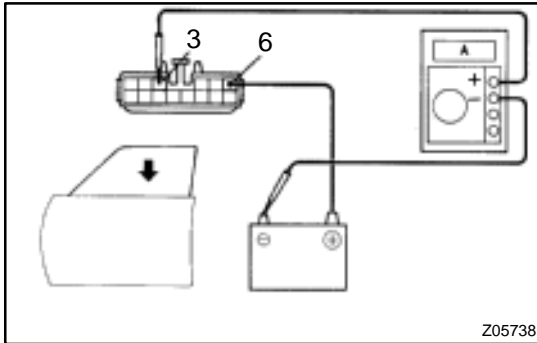

**3. Using an ammeter:
INSPECT ONE-TOUCH POWER WINDOW SYSTEM/
CURRENT OF CIRCUIT**

- Disconnect the connector from the master switch.
- Connect the positive (+) lead from the ammeter to terminal 3 on the wire harness side connector and the negative (-) lead to negative terminal of the battery.
- Connect the positive (+) lead from the battery to terminal 6 on the wire harness side connector.
- As the window goes down, check that the current flow is approximately 7 A.

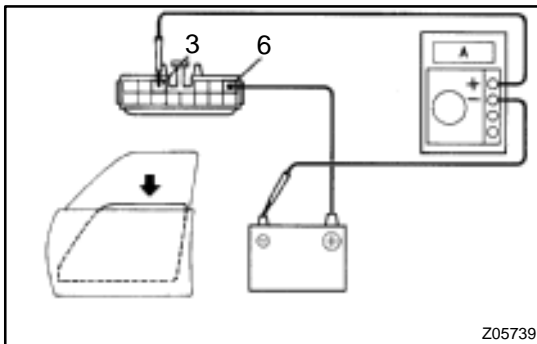

- Check that the current increases up to approximately 14.5 A or more when the window stops going down.

HINT:

The circuit breaker opens some 4 – 40 seconds after the window stops going down, so that check must be done before the circuit breaker operates.

If the operation is as specified, replace the master switch.

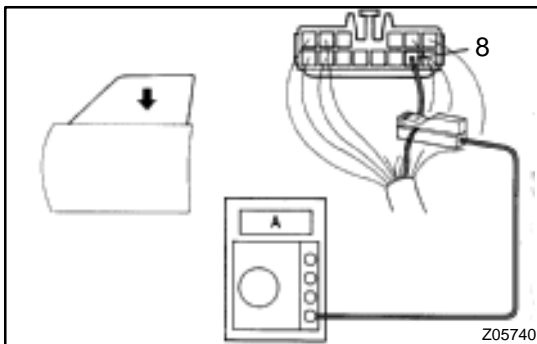

**4. Using an ammeter with a current – measuring probe:
INSPECT ONE-TOUCH POWER WINDOW SYSTEM/
CURRENT OF CIRCUIT**

- Remove the master switch with connector connected.
- Attach a current-measuring probe to terminal 8 of the wire harness.
- Turn the ignition switch ON and set the power window switch in the down position.
- As the window goes down, check that the current flow is approximately 7 A.

- Check that the current increases up to approximately 14.5 A or more when the window stops going down.

HINT:

The circuit breaker opens some 4 – 40 seconds after the window stops going down, so that check must be done before the circuit breaker operates.

If operation is as specified, replace the master switch.

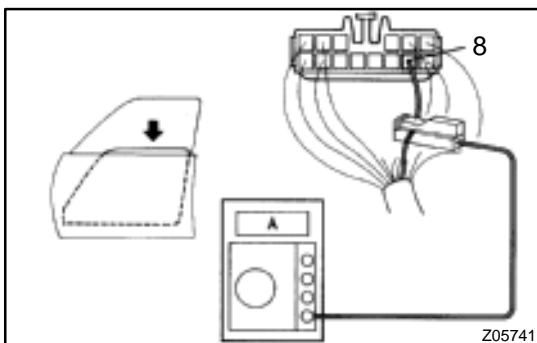

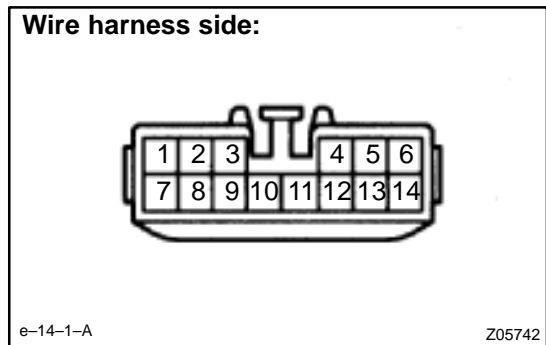

5. INSPECT POWER WINDOW MASTER SWITCH CIRCUIT

Disconnect the connector from the master switch and inspect the connector on the wire harness side, as shown in the following page.

Tester connection	Condition	Specified condition
4 – Ground	Constant	Continuity
8 – Ground	Ignition switch position LOCK or ACC	*No voltage
8 – Ground	Ignition switch position ON	Battery positive voltage

*Exceptions: During 60 seconds after the ignition switch is turned ON to OFF (ACC) or until driver or a passenger's door is opened after the ignition switch is turned ON to OFF (ACC). If the circuit is not as specified, inspect the circuits connected to other parts.

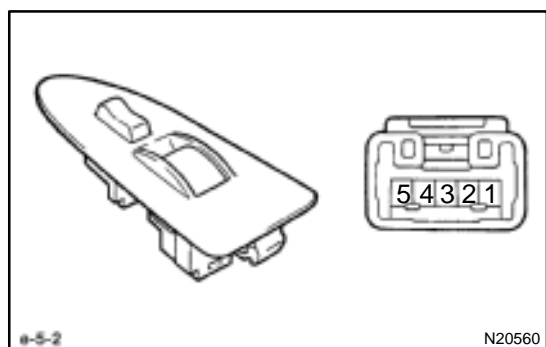

6. Front passenger's door: INSPECT POWER WINDOW SWITCH CONTINUITY

Switch position	Tester connection	Specified condition
UP	1 – 2, 3 – 4	Continuity
OFF	1 – 2, 3 – 5	Continuity
DOWN	1 – 4, 3 – 5	Continuity

If continuity is not as specified, replace the switch.

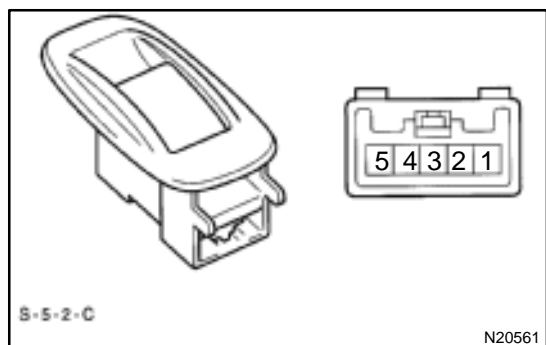

7. Rear door: INSPECT POWER WINDOW SWITCH CONTINUITY

Switch position	Tester connection	Specified condition
UP	1 – 3, 4 – 5	Continuity
OFF	1 – 2, 4 – 5	Continuity
DOWN	1 – 2, 3 – 5	Continuity

If continuity is not as specified, replace the switch.

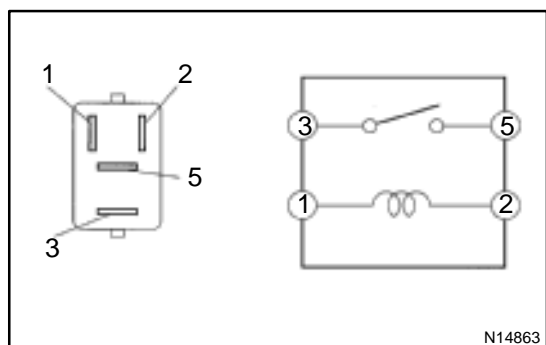

8. INSPECT POWER MAIN RELAY CONTINUITY

Condition	Tester connection	Specified condition
Constant	1 – 2	Continuity
Apply B+ between terminals 1 and 2.	3 – 5	Continuity

If continuity is not as specified, replace the relay.

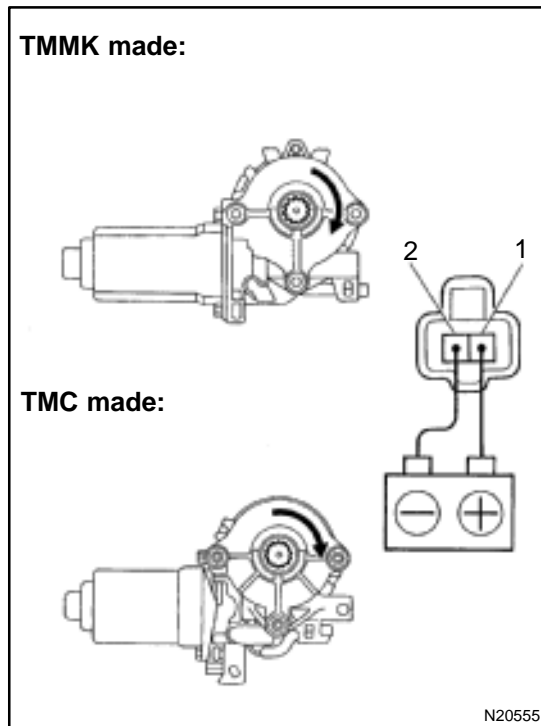

**9. Left side door:
INSPECT MOTOR OPERATION**

- (a) Connect the positive (+) lead from the battery to terminal 1 and the negative (-) lead to terminal 2, and check that the motor turns clockwise.

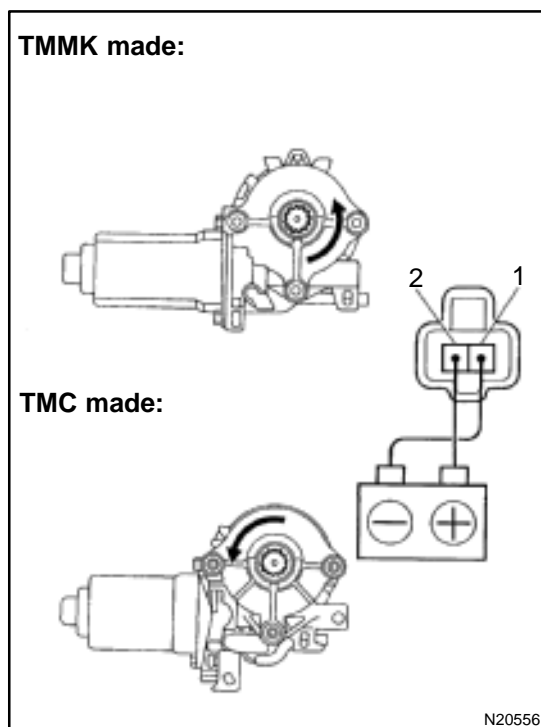

- (b) Reverse the polarity, and check that the motor turns counterclockwise.

If operation is not as specified, replace the motor.

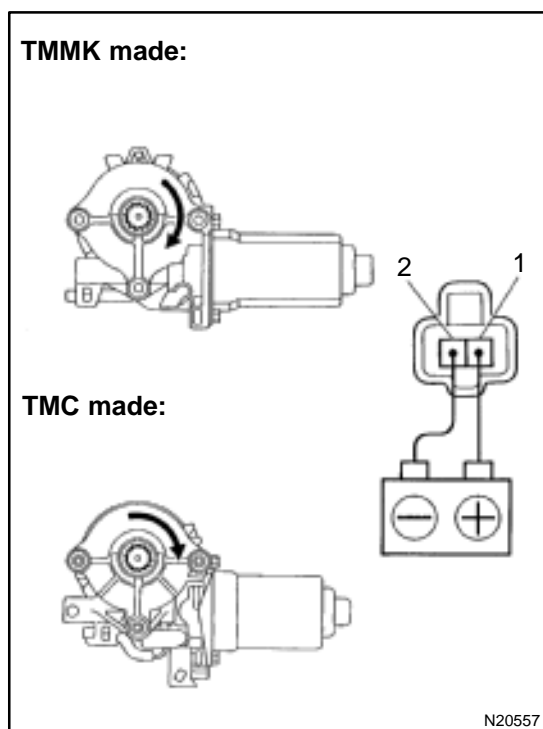

**10. Right side door:
INSPECT MOTOR OPERATION**

- (a) Connect the positive (+) lead from the battery to terminal 1 and the negative (-) lead to terminal 2, and check that the motor turns clockwise.

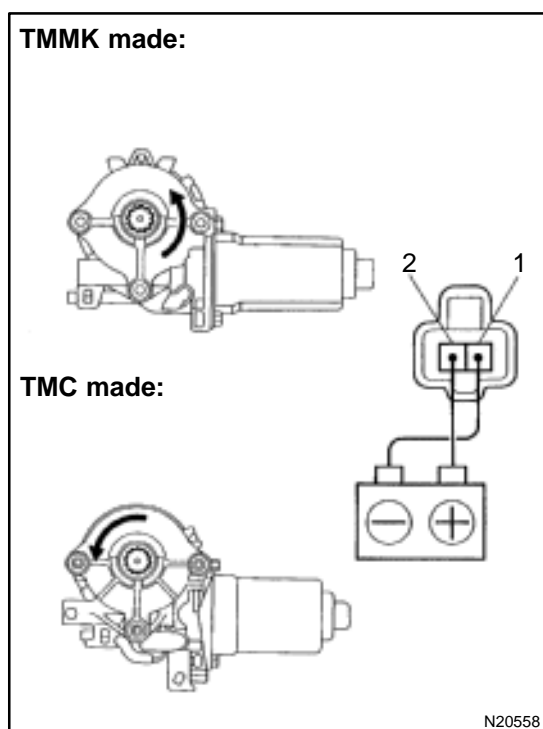

- (b) Reverse the polarity, and check that the motor turns counterclockwise.

If operation is not as specified, replace the motor.

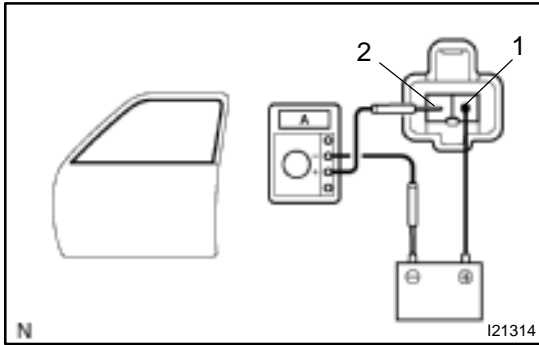

**11. Driver's door:
INSPECT POWER WINDOW MOTOR PTC THERMISTOR OPERATION**

- Disconnect the connector from the master switch.
- Connect the positive (+) lead from the ammeter to terminal 2 on the wire harness side connector and the negative (-) lead to negative terminal of the battery.
- Connect the positive (+) lead from the battery to terminal 1 on the wire harness side connector, and raise the window to the fully position.
- Continue to apply voltage and check that the current changes to less than 1 A within 4 to 90 seconds.
- Disconnect the leads from the terminals.

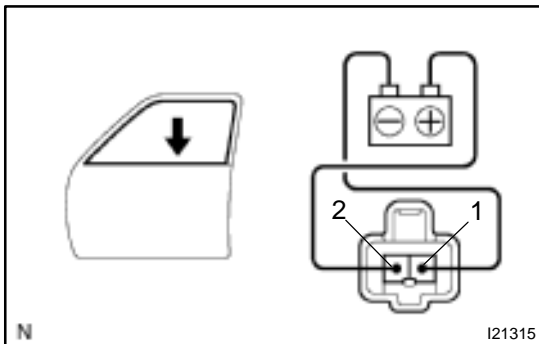

- Approximately 60 seconds later, connect the positive (+) lead from the battery to terminal 2 and the negative (-) lead to terminal 1, and check that the window begins to descend.

If operation is not as specified, replace the motor.

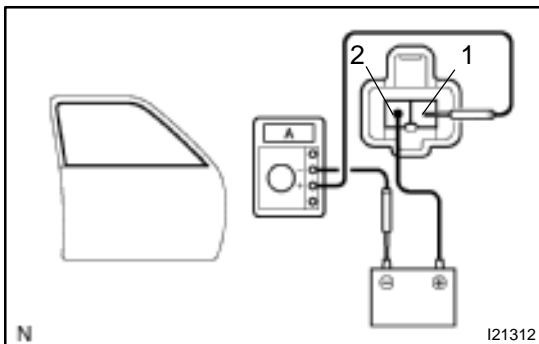

**12. Passenger's door:
INSPECT POWER WINDOW MOTOR PTC THERMISTOR OPERATION**

- Disconnect the connector from the power window switch.
- Connect the positive (+) lead from the ammeter to terminal 1 on the wire harness side connector and the negative (-) lead to negative terminal of the battery.
- Connect the positive (+) lead from the battery to terminal 2 on the wire harness side connector, and raise the window to the fully position.
- Continue to apply voltage and check that the current changes to less than 1 A within 4 to 90 seconds.
- Disconnect the leads from the terminals.

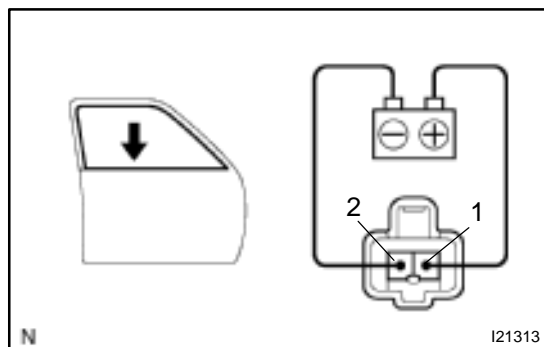

- (f) Approximately 60 seconds later, connect the positive (+) lead from the battery to terminal 1 and the negative (-) lead to terminal 2, and check that the window begins to descend.

If operation is not as specified, replace the motor.

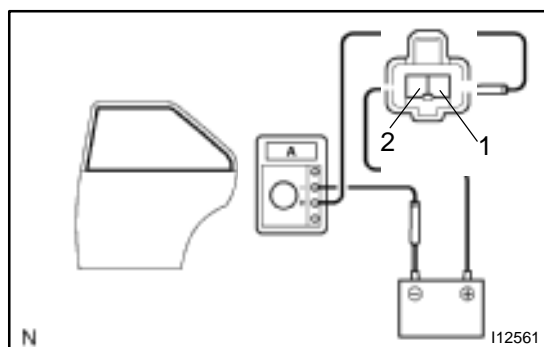

13. Rear Door: INSPECT POWER WINDOW MOTOR PTC THERMISTOR OPERATION

- (a) Disconnect the connector from the power window switch.
 (b) Connect the positive (+) lead from the ammeter to terminal 1 on the wire harness side connector and the negative (-) lead to negative terminal of the battery.
 (c) Connect the positive (+) lead from the battery to terminal 2 on the wire harness side connector, and raise the window to the fully position.
 (d) Continue to apply voltage and check that the current changes to less than 1 A within 4 to 90 seconds.

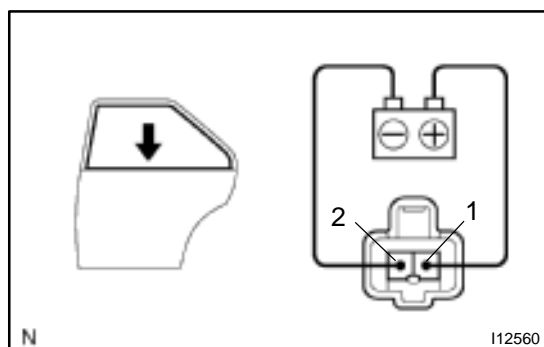

- (e) Disconnect the leads from the terminals.
 (f) Approximately 60 seconds later, connect the positive (+) lead from the battery to terminal 2 and the negative (-) lead to terminal 1, and check that the window begins to descend.

If operation is not as specified, replace the motor.

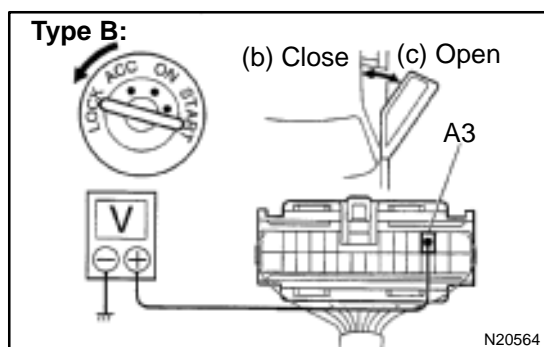

14. Key-off power window signal: INSPECT INTEGRATION RELAY (TYPE B) OPERATION

HINT:

When the relay circuit is as specified, inspect the key-off power window signal.

- (a) Connect the positive (+) lead from the voltmeter to terminal A3 and the negative (-) lead to body ground.
 (b) Close the door with ignition switch turned to LOCK or ACC, and check that the meter needle indicates battery positive voltage.
 (c) Open the door and check that the meter needle indicates 0 V.

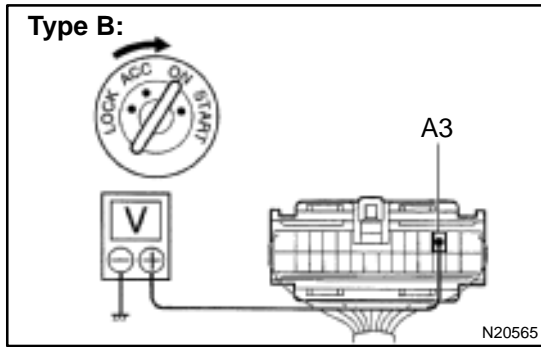

- (d) Turn the ignition switch ON and check that the meter needle indicates battery positive voltage again. If operation is not as specified, replace the relay.

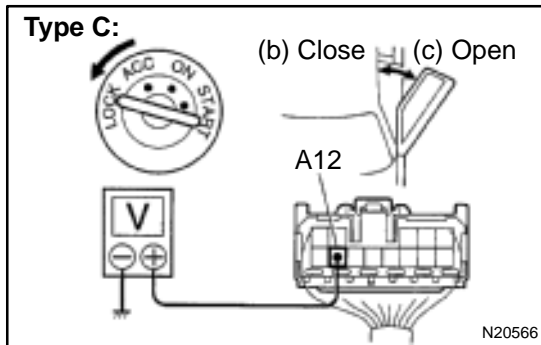

**15. Key-off power window signal:
INSPECT INTEGRATION RELAY (TYPE C) OPERATION**

HINT:

When the relay circuit is as specified, inspect the key-off power window signal.

- (a) Connect the positive (+) lead from the voltmeter to terminal A12 and the negative (-) lead to body ground.
 (b) Close the door with ignition switch turned to LOCK or ACC, and check that the meter needle indicates battery positive voltage.

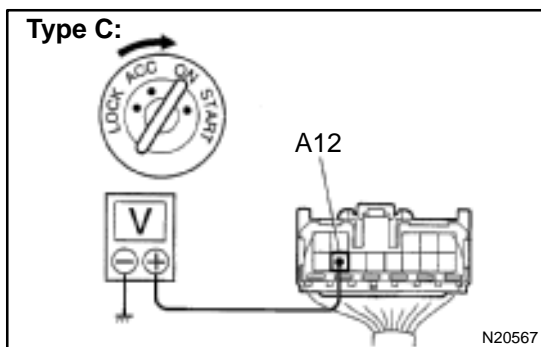

- (c) Open the door and check that the meter needle indicates 0 V.
 (d) Turn the ignition switch ON and check that the meter needle indicates battery positive voltage again.

If operation is not as specified, replace the relay.
**16. INSPECT INTEGRATION RELAY CIRCUIT
(See page XX-XXX)**

POWER DOOR LOCK CONTROL SYSTEM

LOCATION

BE0AP-02

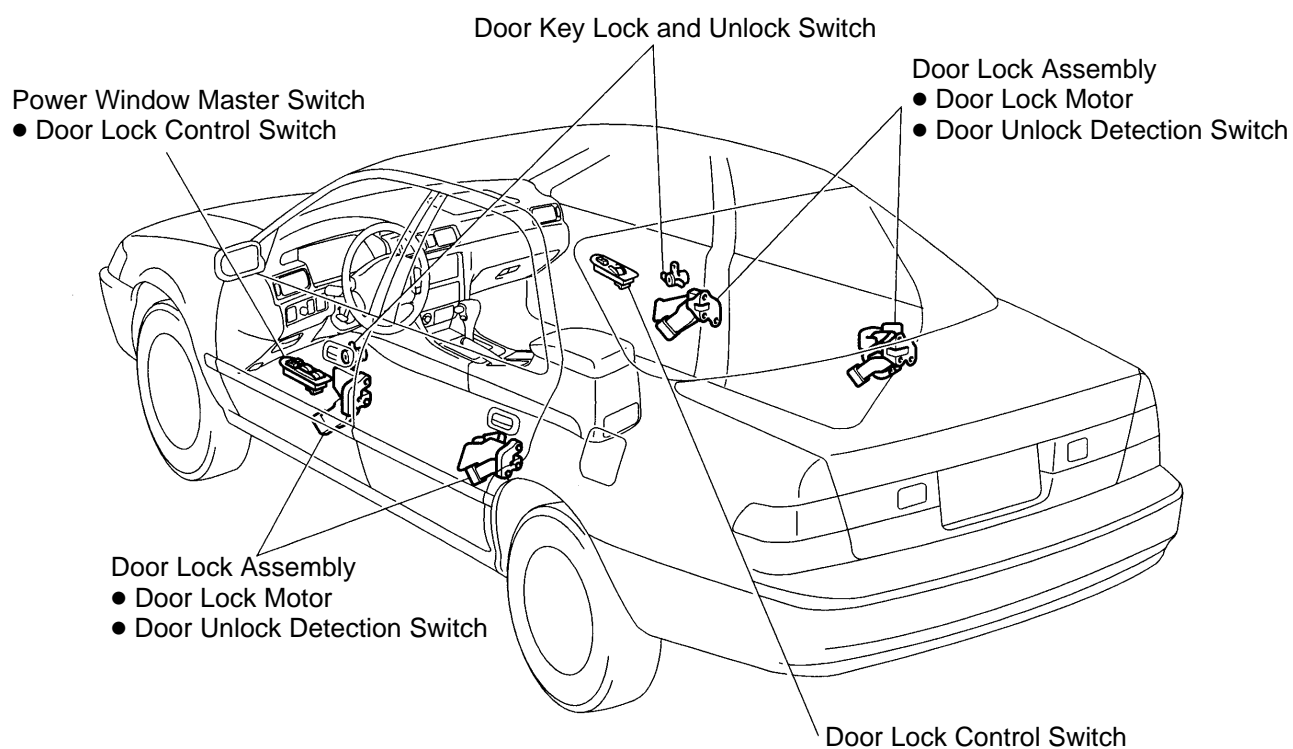
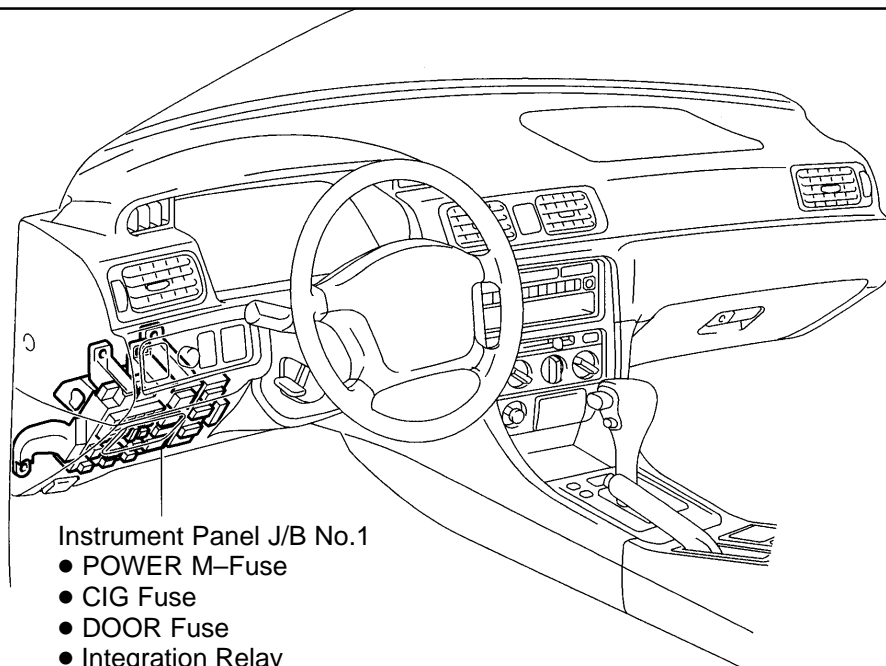
N20671
N20672

Z19053

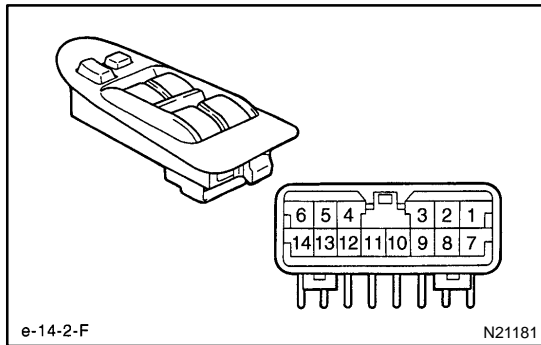

INSPECTION

- Master switch:
INSPECT DRIVER'S DOOR LOCK CONTROL SWITCH CONTINUITY**

Switch position	Tester connection	Specified condition
LOCK	2 – 4	Continuity
OFF	–	No continuity
UNLOCK	4 – 7	Continuity

If continuity is not as specified, replace the switch.

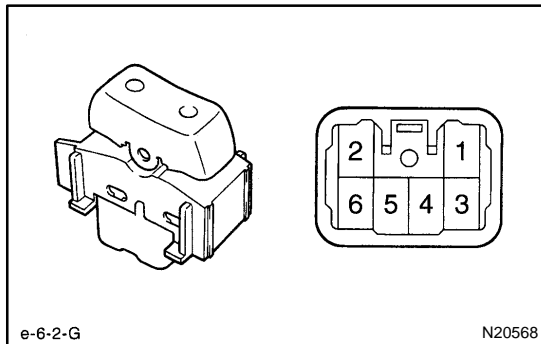

- INSPECT PASSENGER'S DOOR LOCK CONTROL SWITCH CONTINUITY**

Switch position	Tester connection	Specified condition
LOCK	3 – 6	Continuity
OFF	–	No continuity
UNLOCK	3 – 5	Continuity

If continuity is not as specified, replace the switch.

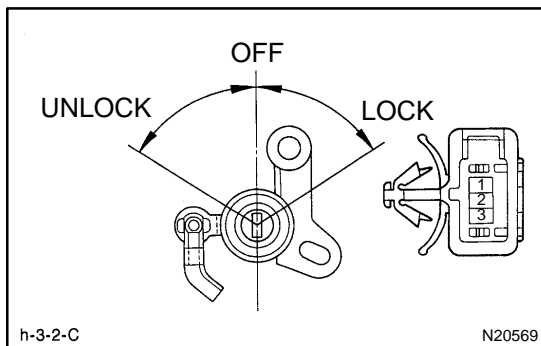

- w/ Theft deterrent system:
INSPECT DOOR KEY LOCK AND UNLOCK SWITCH CONTINUITY**

Switch position	Tester connection	Specified condition
LOCK	2 – 1	Continuity
OFF	–	No continuity
UNLOCK	3 – 1	Continuity

If continuity is not as specified, replace the switch.

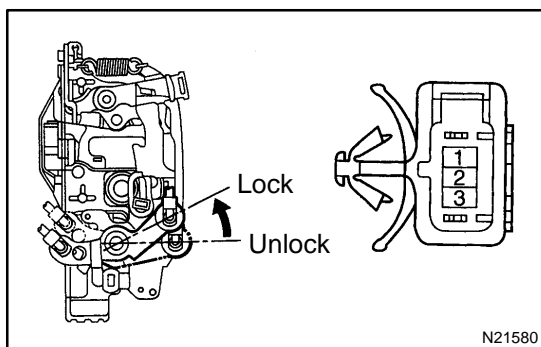

- w/o Theft deterrent system:
INSPECT DOOR KEY LOCK AND UNLOCK SWITCH CONTINUITY**

Switch position	Tester connection	Specified condition
LOCK	2 – 1	Continuity
OFF	–	No continuity
UNLOCK	3 – 1	Continuity

If continuity is not as specified, replace the switch.

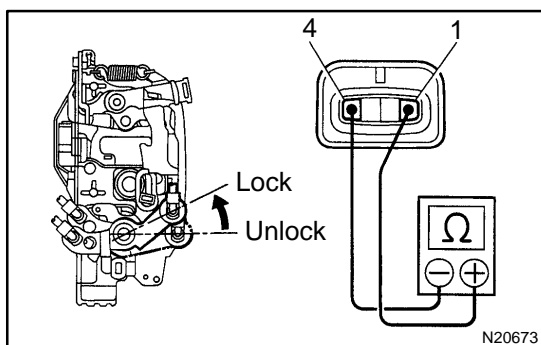

- INSPECT DOOR UNLOCK DETECTION SWITCH CONTINUITY**

Switch position	Tester connection	Specified condition
OFF (Door Lock set to LOCK)	–	No continuity
ON (Door Lock set to UNLOCK)	1 – 4	Continuity

If continuity is not as specified, replace the switch.

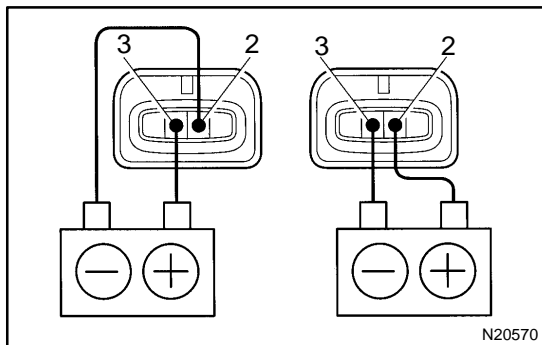
**6. INSPECT MOTOR OPERATION**

- (a) Connect the positive (+) lead from the battery to terminal 3 and the negative (-) lead to terminal 2, and check that the door lock link moves to UNLOCK position.
- (b) Remove the polarity and check that the door lock link moves to LOCK position.

If operation is not as specified, replace the door lock assembly.

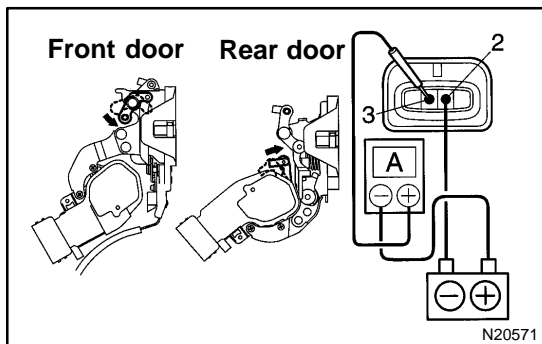
**7. Using an ammeter:****INSPECT PTC THERMISTOR OPERATION**

- (a) Connect the positive (+) lead from the battery to terminal 3.
- (b) Connect the positive (+) lead from the ammeter to terminal 2 and the negative (-) lead to battery negative (-) terminal, and check that the current changes from approximately 3.2 A to less than 0.5 A within 20 to 70 seconds.

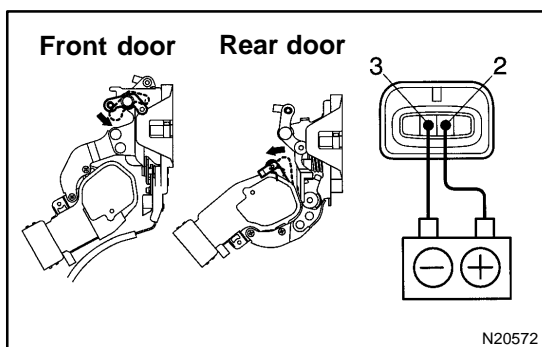

- (c) Disconnect the leads from terminals.
- (d) Approximately 60 seconds later, connect the positive (+) lead from the battery to terminal 2 and the negative (-) lead to terminal 3, and check that the door lock moves to the LOCK position.

If operation is not as specified, replace the door lock assembly.

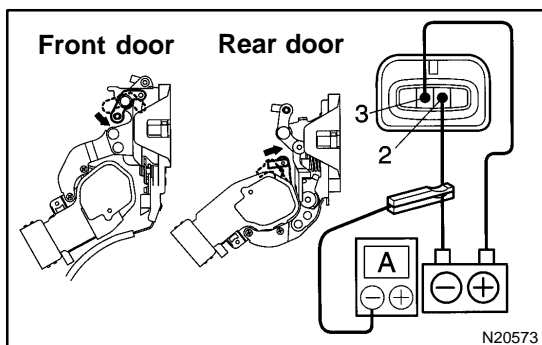
**8. Using an ammeter with a current-measuring probe:****INSPECT PTC THERMISTOR OPERATION**

- (a) Connect the positive (+) lead from the battery to terminal 3 and the negative (-) lead to terminal 2.
- (b) Attach a current-measuring probe to either the positive (+) lead or the negative (-) lead, and check that the current changes from approximately 3.2 A to less than 0.5 A within 20 to 70 seconds.

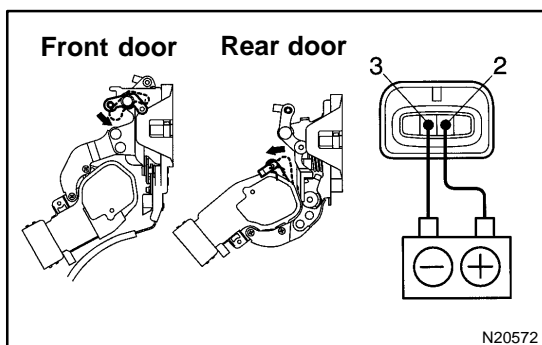

- (c) Disconnect the leads from terminals.
- (d) Approximately 60 seconds later, reverse the polarity, and check that the door lock moves to the LOCK position.

If operation is not as specified, replace the door lock assembly.

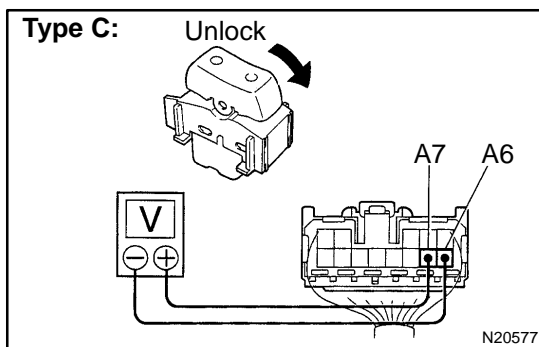
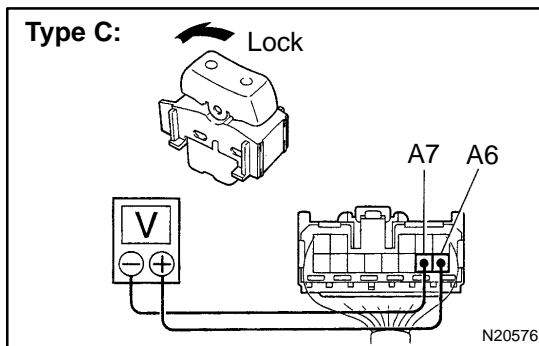
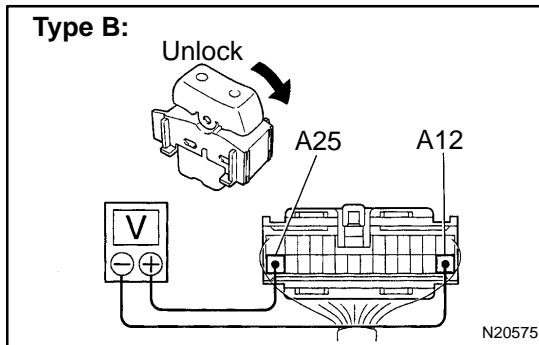
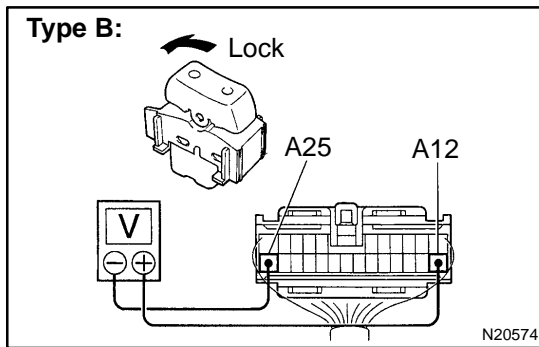

9. Door lock signal: INSPECT INTEGRATION RELAY (Type B) OPERATION

HINT:

When the relay circuit is as specified, inspect the door lock signal.

- Connect the positive (+) lead from the voltmeter to terminal A12 and the negative (-) lead to terminal A25.
- Set the door lock control switch to UNLOCK and check that the voltage rises from 0 V to battery positive voltage for approximately 0.2 seconds.
- Reverse the polarity of the voltmeter leads.
- Set the door lock control switch to LOCK and check that the voltage rises from 0 V to battery positive voltage for approximately 0.2 seconds.

If operation is not as specified, replace the relay.

10. Door lock signal: INSPECT INTEGRATION RELAY (Type C) OPERATION

HINT:

When the relay circuit is as specified, inspect the door lock signal.

- Connect the positive (+) lead from the voltmeter to terminal A6 and the negative (-) lead to terminal A7.
- Set the door lock control switch to UNLOCK and check that the voltage rises from 0 V to battery positive voltage for approximately 0.2 seconds.
- Reverse the polarity of the voltmeter leads.
- Set the door lock control switch to LOCK and check that the voltage rises from 0 V to battery positive voltage for approximately 0.2 seconds.

If operation is not as specified, replace the relay.

11. INSPECT INTEGRATION RELAY CIRCUIT (See page BE-14)

SLIDING ROOF SYSTEM LOCATION

BE0AR-02

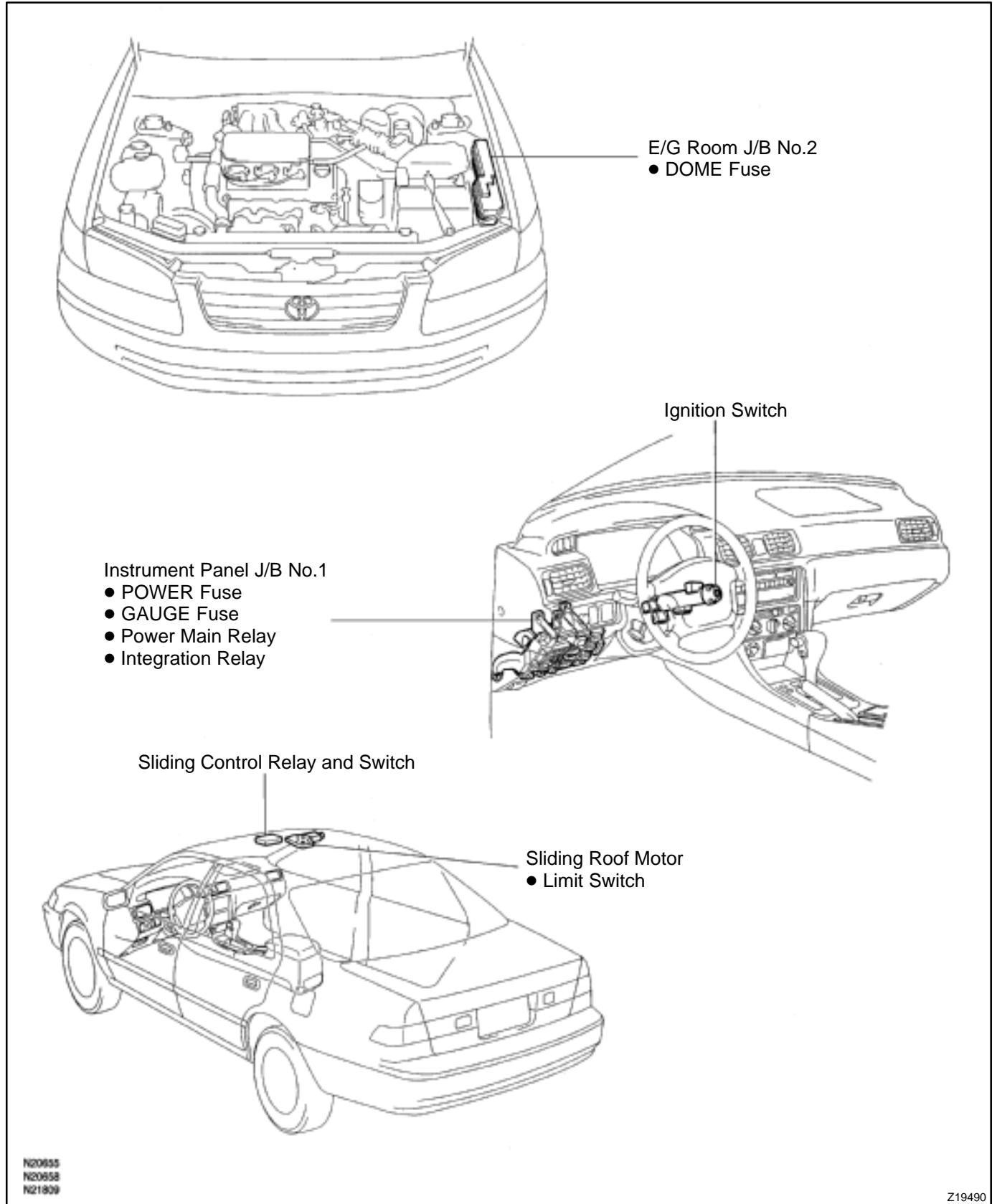

Wire harness side:

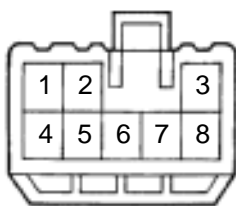

s-8-1

N21643

INSPECTION

1. INSPECT SLIDING ROOF CONTROL RELAY AND SWITCH CIRCUIT

Disconnect the connector from the relay and switch and inspect the connector on the wire harness side, as shown in the table.

TMMK made:

Tester connection	Condition	Specified condition
1 – 5	Constant	Continuity
2 – Ground	Constant	Continuity
3 – Ground	Limit switch No.1 is OFF (Sliding roof is in a closed position)	No continuity
3 – Ground	Limit switch No.1 is ON (Sliding roof is in an open position)	Continuity
7 – Ground	Limit switch No.2 is OFF (Sliding roof is in a tilt up position)	No continuity
7 – Ground	Limit switch No.2 is ON (Sliding roof is in the open position)	Continuity
8 – Ground	Limit switch No.3 is OFF (Sliding roof is in a closed position)	No continuity
8 – Ground	Limit switch No.3 is ON (Sliding roof is in an open position)	Continuity
4 – Ground	Ignition switch is in a LOCK or ACC position	* No voltage
4 – Ground	Ignition switch is in an ON position	Battery positive voltage

TMC made:

Tester connection	Condition	Specified condition
1 – 5	Constant	Continuity
2 – Ground	Constant	Continuity
3 – Ground	No.1 limit switch OFF (Sliding roof closed)	No continuity
3 – Ground	No.1 limit switch ON (Sliding roof opened)	Continuity
7 – Ground	No.2 limit switch OFF (Sliding roof tilted up open approx. 200 mm (7.87 in.))	No continuity
7 – Ground	No.2 limit switch ON (Except for conditions mentioned above)	Continuity
4 – Ground	Ignition switch LOCK or ACC	* No voltage
4 – Ground	Ignition switch ON	Battery positive voltage

*: Exceptions: For 60 seconds after the ignition switch is turned ON to OFF (ACC) or until driver or passenger door is opened after the ignition switch is turned ON to OFF (ACC).
If the circuit is not as specified, replace the relay and switch.

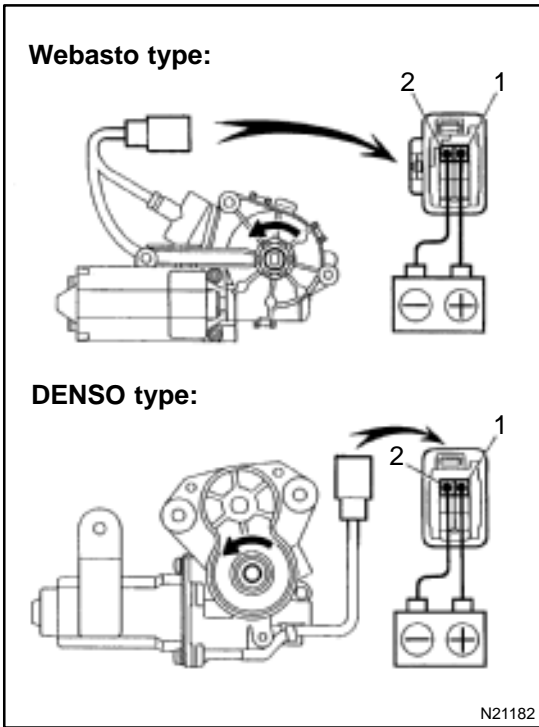

2. INSPECT SLIDING ROOF MOTOR OPERATION

- (a) Connect the positive (+) lead from the battery to terminal 2 and the negative (-) lead to terminal 1, check that the motor turns counterclockwise (moves to the close and up side).

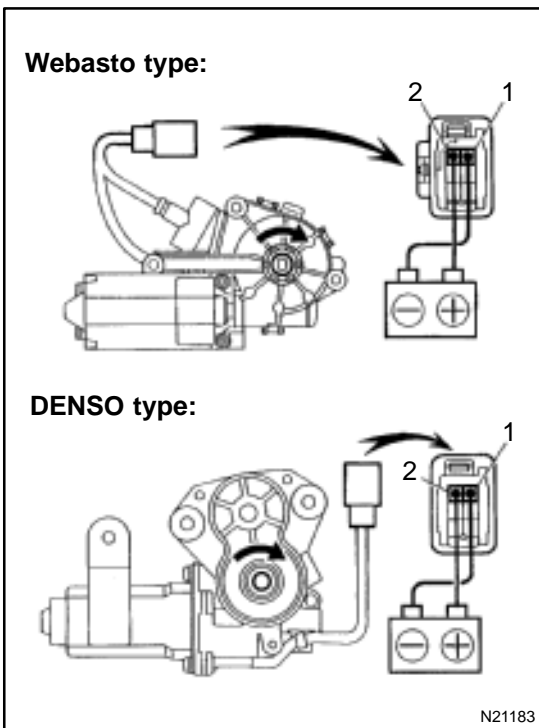

- (b) Reverse the polarity, check that the motor turns clockwise (moves to the open and down side).
If operation is not as specified, replace the motor.

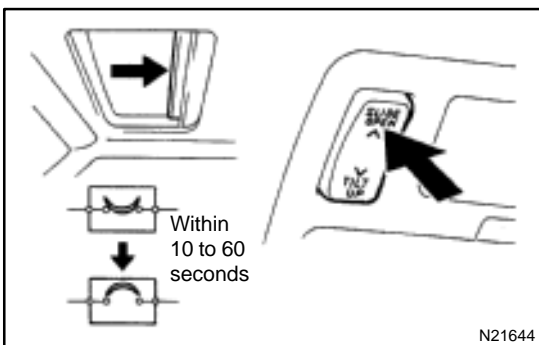

3. INSPECT CIRCUIT BREAKER OPERATION

- (a) With the sliding roof in the fully opened position, hold the sliding roof switch in "OPEN" position and check that a circuit breaker operation noise is heard within 10 to 60 seconds.

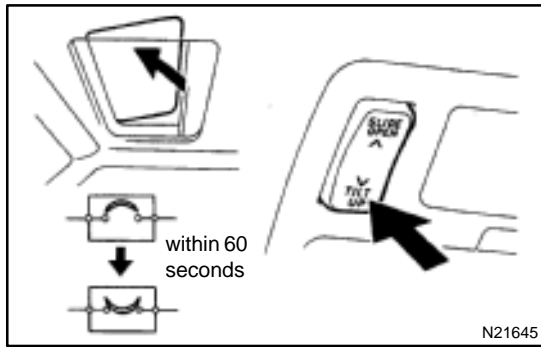

(b) With the sliding roof in fully opened position, hold the sliding roof switch in "TILT UP" position and check that the sliding roof begins to close within 60 seconds. If operation is not as specified, replace the motor.

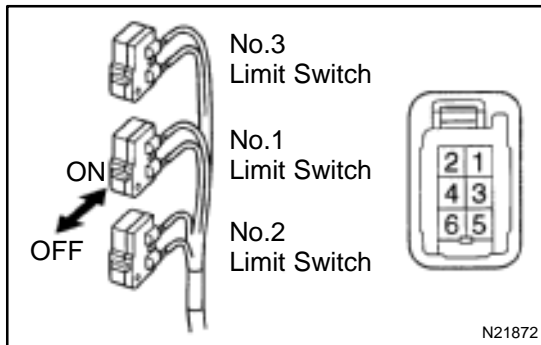

**4. TMMK made:
INSPECT SLIDING ROOF LIMIT SWITCH CIRCUIT**

Switch position	Tester connection	Specified condition
No.1 limit switch OFF (SW pin released)	3 – 5	No continuity
No.1 limit switch ON (SW pin pushed in)	3 – 5	Continuity
No.2 limit switch OFF (SW pin released)	3 – 6	No continuity
No.2 limit switch ON (SW pin pushed in)	3 – 6	Continuity
No.3 limit switch OFF (SW pin released)	3 – 4	No continuity
No.3 limit switch ON (SW pin pushed in)	3 – 4	Continuity

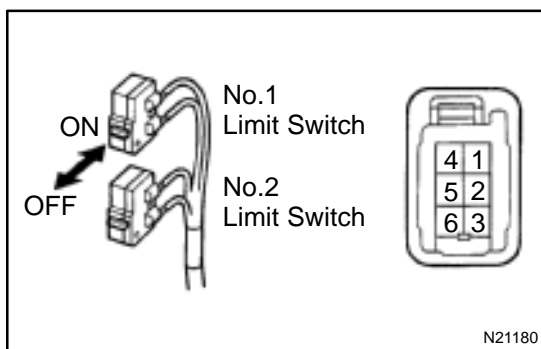

**5. TMC made:
INSPECT SLIDING ROOF LIMIT SWITCH CIRCUIT**

Switch position	Tester connection	Specified condition
No.1 limit switch OFF (SW pin released)	4 – 5	No continuity
No.1 limit switch ON (SW pin pushed in)	4 – 5	Continuity
No.2 limit switch OFF (SW pin released)	4 – 6	No continuity
No.2 limit switch ON (SW pin pushed in)	4 – 6	Continuity

If continuity is not as specified, replace the switch.

**6. INSPECT KEY-OFF SLIDING ROOF OPERATION
(See integration relay circuit on page BE-14)**

POWER SEAT CONTROL SYSTEM LOCATION

BE0AT-02

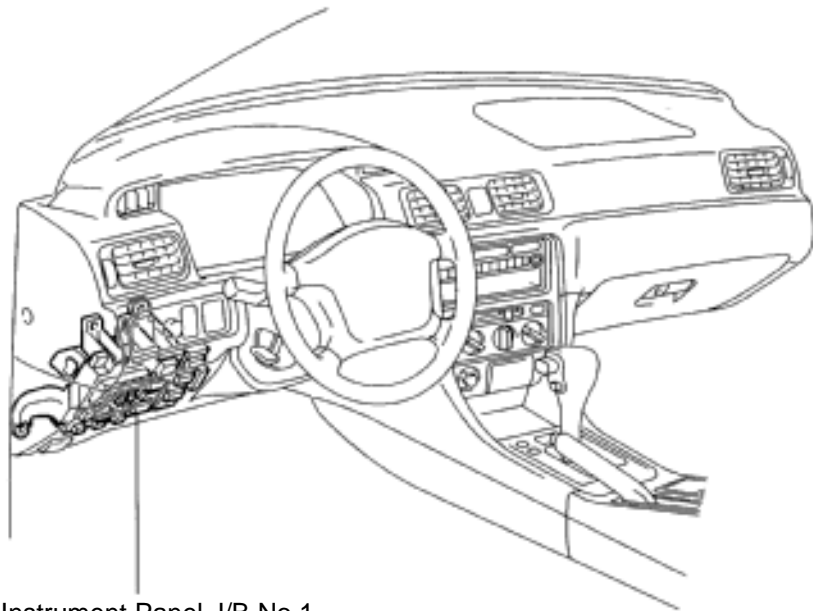

Instrument Panel J/B No.1
● CIG Fuse

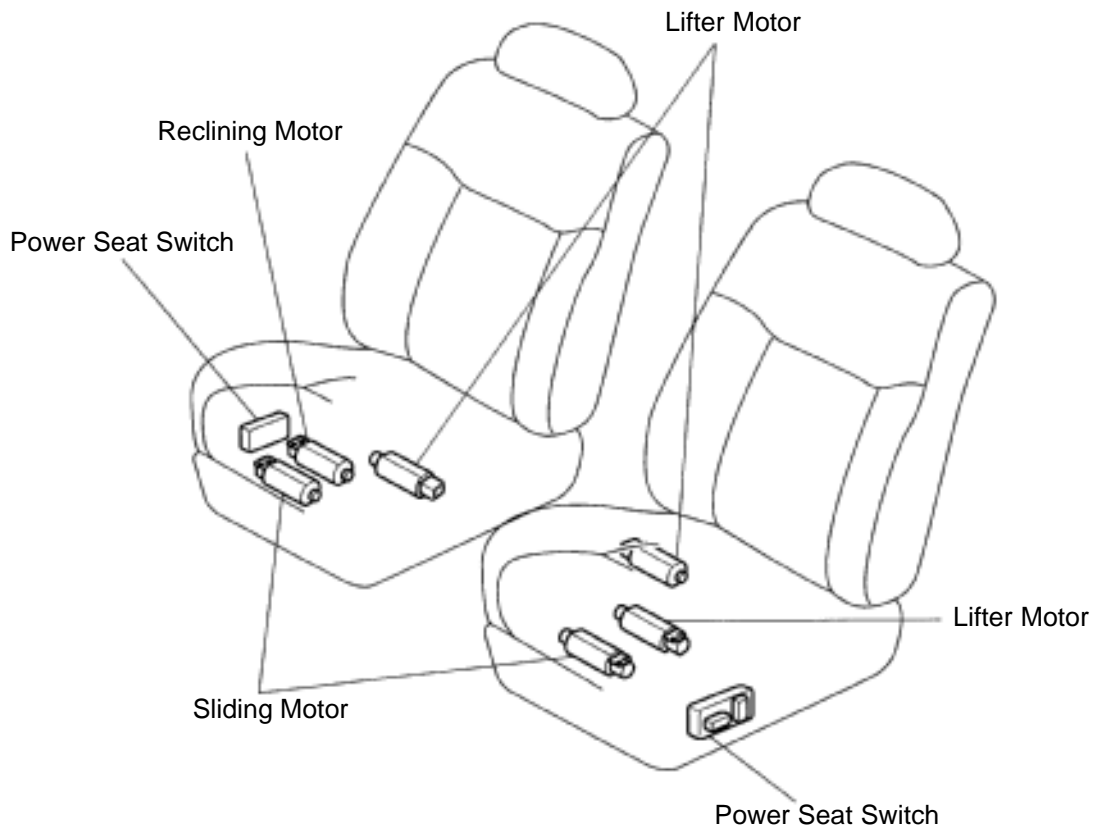

N20056
N21008

Z19504

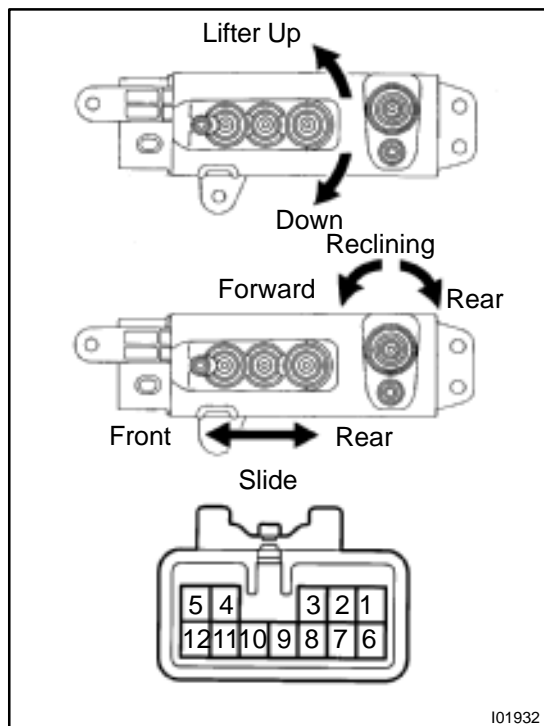

I01932

INSPECTION

1. TMC made: INSPECT DRIVER'S SEAT SWITCH CONTINUITY

(a) Inspect the slide switch.

Switch position	Tester connection	Specified condition
FRONT	4 – 6, 8 – 11	Continuity
OFF	4 – 6, 6 – 8	Continuity
BACK	6 – 8, 4 – 11	Continuity

(b) Inspect the lifter switch.

Switch position	Tester connection	Specified condition
UP	2 – 11, 3 – 6	Continuity
OFF	3 – 6, 2 – 6	Continuity
DOWN	2 – 6, 3 – 11	Continuity

(c) Inspect the reclining switch.

Switch position	Tester connection	Specified condition
FORWARD	1 – 11, 5 – 6	Continuity
OFF	1 – 6, 5 – 6	Continuity
REAR	1 – 6, 5 – 11	Continuity

If continuity is not as specified, replace the switch.

2. TMMK made: INSPECT DRIVER'S SEAT SWITCH CONTINUITY

(a) Inspect the slide switch.

Switch position	Tester connection	Specified condition
FRONT	2 – 11, 4 – 7	Continuity
OFF	4 – 11, 4 – 7	Continuity
BACK	2 – 7, 4 – 11	Continuity

(b) Inspect the lifter switch.

Switch position	Tester connection	Specified condition
UP	2 – 5, 4 – 8	Continuity
OFF	4 – 5, 4 – 8	Continuity
DOWN	2 – 8, 4 – 5	Continuity

(c) Inspect the reclining switch.

Switch position	Tester connection	Specified condition
FORWARD	2 – 12, 4 – 6	Continuity
OFF	4 – 12, 4 – 6	Continuity
REAR	2 – 6, 4 – 12	Continuity

If continuity is not as specified, replace the switch.

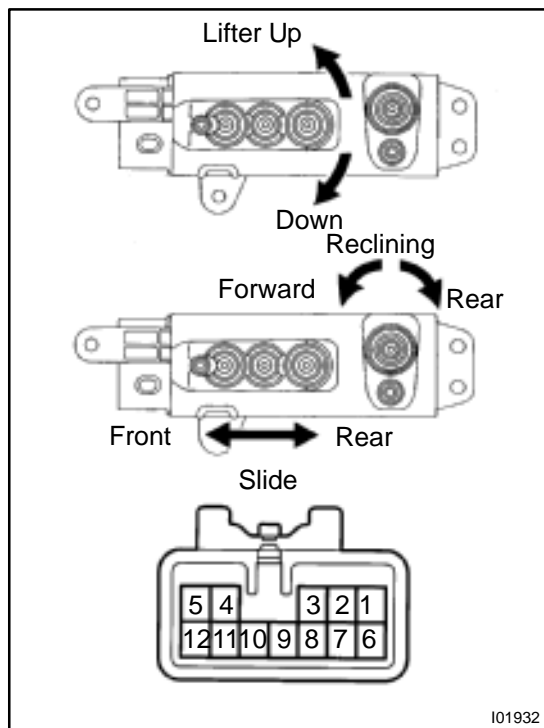

3. TMC made: INSPECT PASSENGER'S SEAT CONTINUITY

(a) Inspect the slide switch.

Switch position	Tester connection	Specified condition
FRONT	4 – 6, 8 – 11	Continuity
OFF	4 – 6, 6 – 8	Continuity
BACK	6 – 8, 4 – 11	Continuity

(b) Inspect the lifter switch.

Switch position	Tester connection	Specified condition
UP	2 – 6, 3 – 11	Continuity
OFF	3 – 6, 2 – 6	Continuity
DOWN	3 – 6, 2 – 11	Continuity

(c) Inspect the reclining switch.

Switch position	Tester connection	Specified condition
FORWARD	5 – 6, 1 – 11	Continuity
OFF	1 – 6, 5 – 6	Continuity
REAR	1 – 6, 5 – 11	Continuity

If continuity is not as specified, replace the switch.

4. TMMK made: INSPECT PASSENGER'S SEAT CONTINUITY

(a) Inspect the slide switch.

Switch position	Tester connection	Specified condition
FRONT	2 – 11, 4 – 7	Continuity
OFF	4 – 11, 4 – 7	Continuity
BACK	2 – 7, 4 – 11	Continuity

(b) Inspect the lifter switch.

Switch position	Tester connection	Specified condition
UP	2 – 8, 4 – 5	Continuity
OFF	4 – 5, 4 – 8	Continuity
DOWN	2 – 5, 4 – 8	Continuity

(c) Inspect the reclining switch.

Switch position	Tester connection	Specified condition
FORWARD	2 – 12, 4 – 6	Continuity
OFF	4 – 12, 4 – 6	Continuity
REAR	2 – 6, 4 – 12	Continuity

If continuity is not as specified, replace the switch.

5. INSPECT SLIDE MOTOR OPERATION

- (a) Connect the positive (+) lead from the battery to terminal 2 and the negative (–) lead to terminal 1, check that the motor turns counterclockwise.
- (b) Reverse the polarity, check that the motor turns clockwise.

If operation is not as specified, replace the seat adjuster.

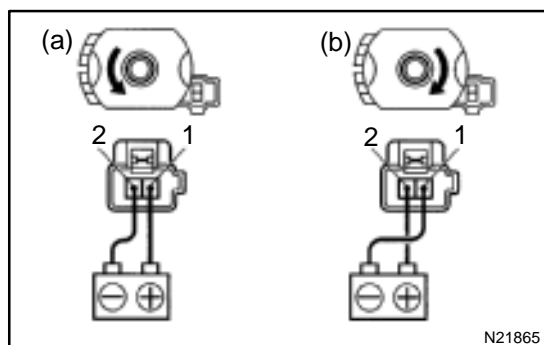

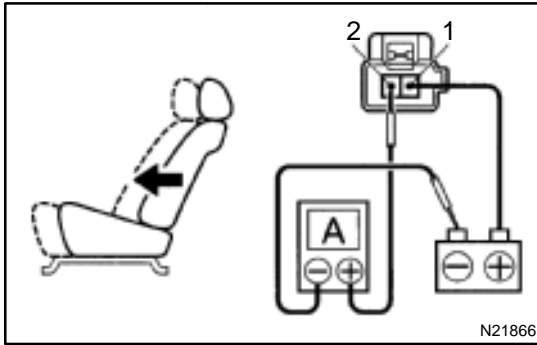

6. INSPECT SLIDE MOTOR PTC THERMISTOR OPERATION

- (a) Connect the positive (+) lead from the battery to terminal 1, the positive (+) lead from the ammeter to terminal 2 and the negative (-) lead to the battery negative (-) terminal, then move the seat cushion to the front position.
- (b) Continue to apply voltage, check that the current changes to less than 1 ampere within 4 to 90 seconds.

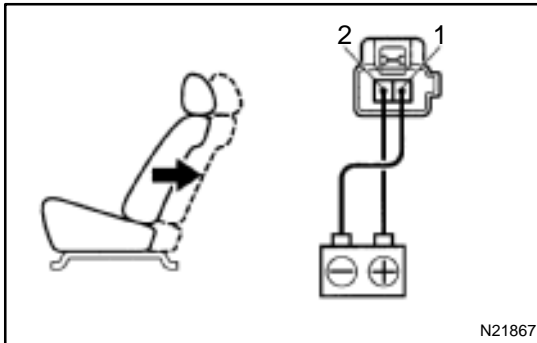

- (c) Disconnect the leads from terminals.
- (d) Approximately 60 seconds later, connect the positive (+) lead from the battery to terminal 2 and the negative (-) lead to terminal 1, check that the seat cushion begins to move backwards.

If operation is not as specified, replace the seat adjuster.

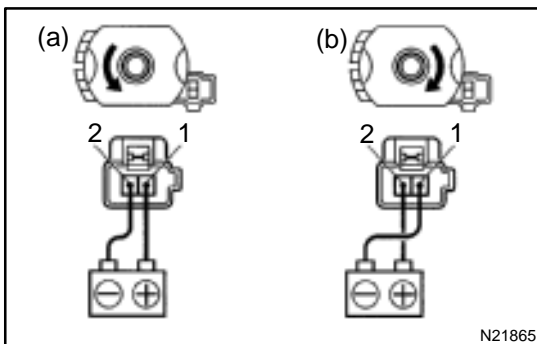

7. INSPECT LIFTER MOTOR OPERATION

- (a) Connect the positive (+) lead from the battery to terminal 2 and the negative (-) lead to terminal 1, check that the motor turns counterclockwise.
- (b) Reverse the polarity, check that the motor turns clockwise.

If operation is not as specified, replace the seat adjuster.

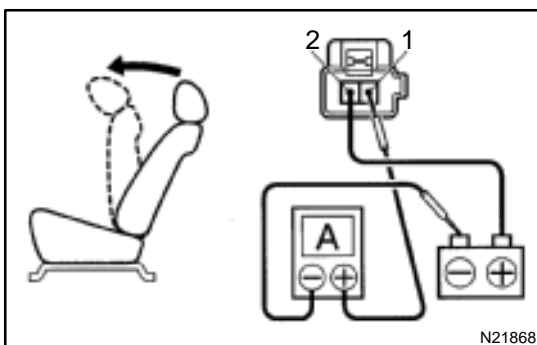

8. INSPECT LIFTER PTC THERMISTOR OPERATION

- (a) Connect the positive (+) lead from the battery to terminal 1, the positive (+) lead from the ammeter to terminal 2 and the negative (-) lead to the battery negative (-) terminal, then move the seat cushion to the highest position.
- (b) Continue to apply voltage, check that the current changes to less than 1 ampere within 4 to 90 seconds.

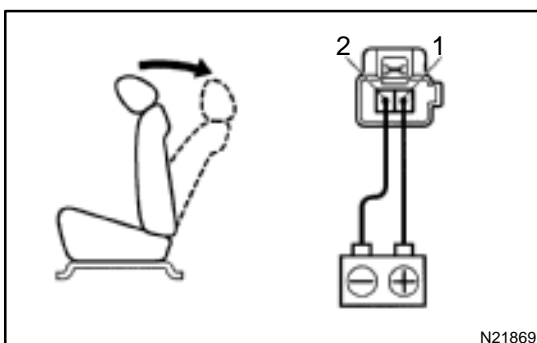

- (c) Disconnect the leads from the terminals.
- (d) Approximately 60 seconds later, connect the positive (+) lead from the battery to terminal 2 and the negative (-) lead to terminal 1, check that the seat cushion begins to fall down.

If operation is not as specified, replace the seat adjuster.

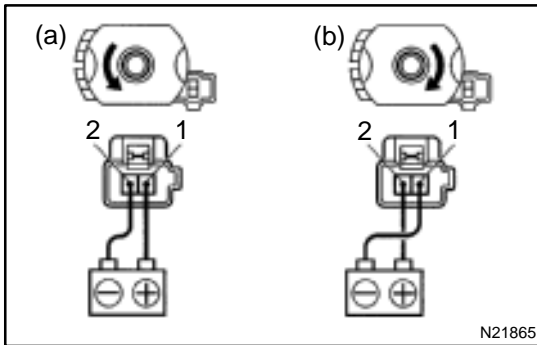
**9. INSPECT RECLINING MOTOR OPERATION**

- (a) Connect the positive (+) lead from the battery to terminal 2 and the negative (-) lead to terminal 1, check that the motor turns counterclockwise.
- (b) Reverse the polarity, check that the motor turns clockwise.

If operation is not as specified, replace the seat adjuster.

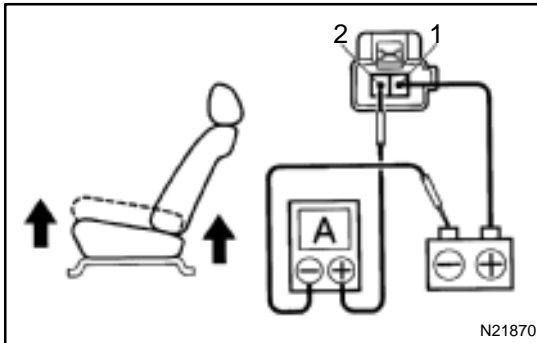
**10. INSPECT RECLINING MOTOR PTC THERMISTOR OPERATION**

- (a) Connect the positive (+) lead from the battery to terminal 2, the positive (+) lead from the ammeter to terminal 1 and the negative (-) lead to the battery negative (-) terminal, then recline the seat back to the most forward position.
- (b) Continue to apply voltage, check that the current change to less than 1 ampere within 4 to 90 seconds.

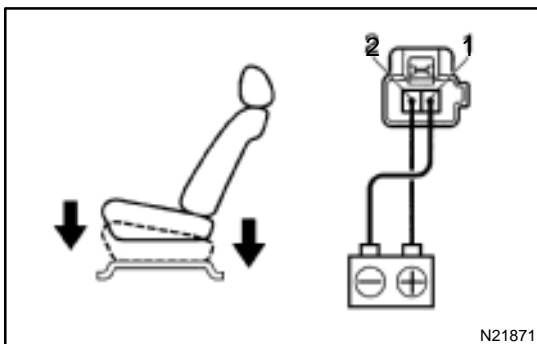

- (c) Disconnect the leads from the terminals.
- (d) Approximately 60 seconds later, connect the positive (+) lead from the battery to terminal 1 and the negative (-) lead to terminal 2, check that the seat back starts to fall backward.

If operation is not as specified, replace the seat adjuster.

POWER MIRROR CONTROL SYSTEM LOCATION

BE0AV-03

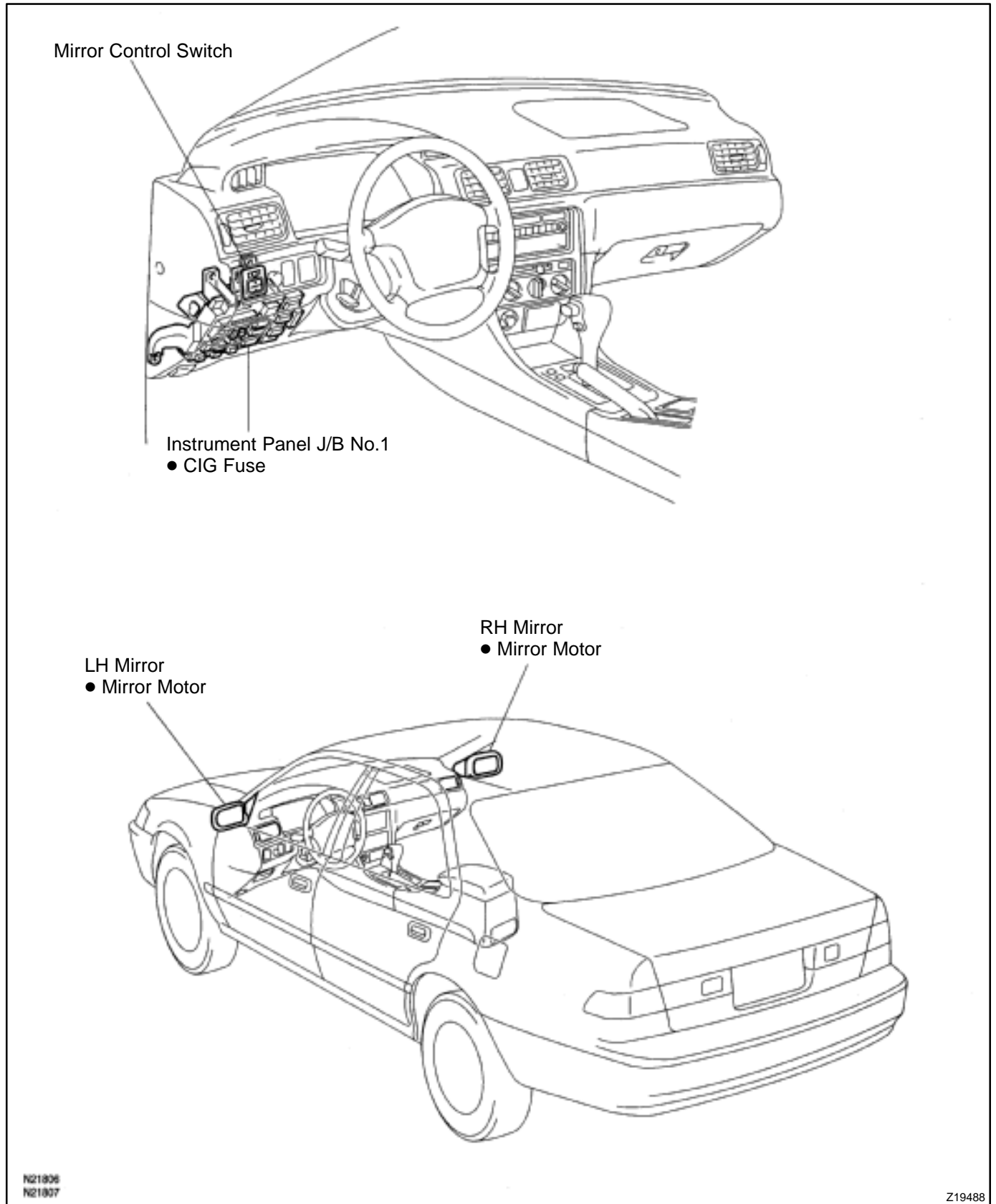

N21806
N21807

Z19488

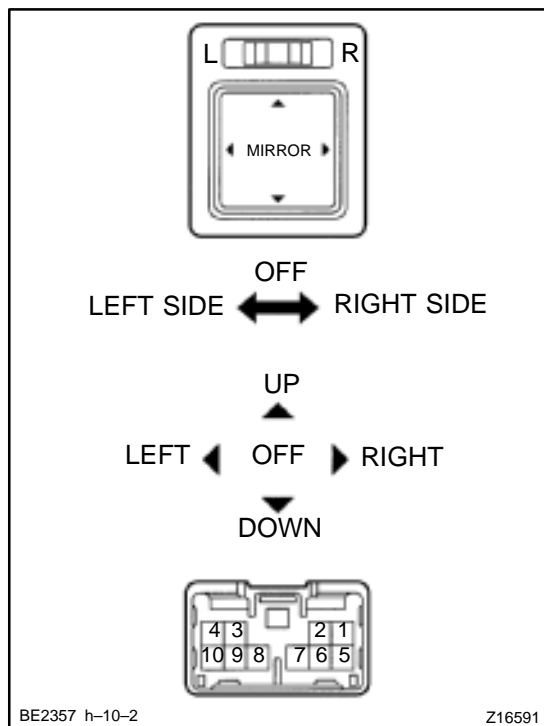

INSPECTION

1. Master switch left side:

INSPECT MIRROR CONTROL SWITCH CONTINUITY

Switch position	Tester connection	Specified condition
OFF	-	No continuity
UP	1 - 9, 6 - 10	Continuity
DOWN	1 - 10, 6 - 9	Continuity
LEFT	5 - 9, 6 - 10	Continuity
RIGHT	5 - 10, 6 - 9	Continuity

If continuity is not as specified, replace the switch.

2. Master switch right side:

INSPECT MIRROR CONTROL SWITCH CONTINUITY

Switch position	Tester connection	Specified condition
OFF	-	No continuity
UP	6 - 10, 7 - 9	Continuity
DOWN	6 - 9, 7 - 10	Continuity
LEFT	6 - 10, 8 - 9	Continuity
RIGHT	6 - 9, 8 - 10	Continuity

If continuity is not as specified, replace the switch.

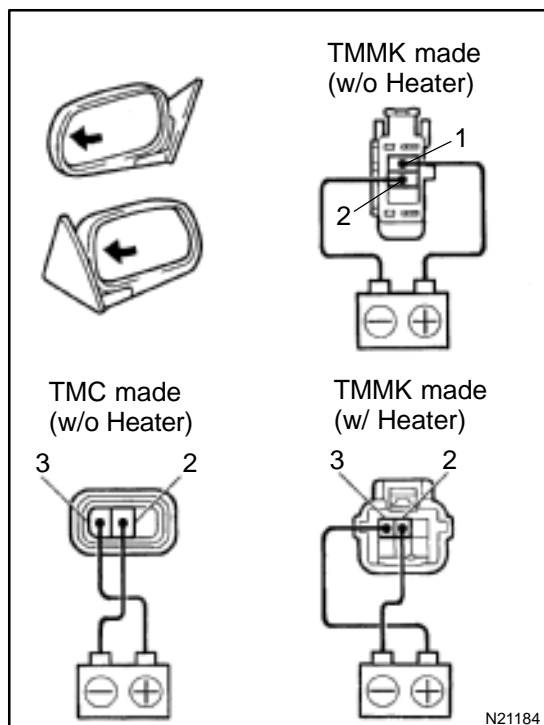

3. INSPECT MIRROR MOTOR

(a) TMMK made (w/o Heater):

Connect the positive (+) lead from the battery to terminal 1 and negative (-) lead to terminal 2, check that the mirror turns to left side.

(b) TMC made (w/o Heater):

Connect the positive (+) lead from the battery to terminal 3 and negative (-) lead to terminal 2, check that the mirror turns to left side.

(c) TMMK made (w/ Heater):

Connect the positive (+) lead from the battery to terminal 3 and negative (-) lead to terminal 2, check that the mirror turns to left side.

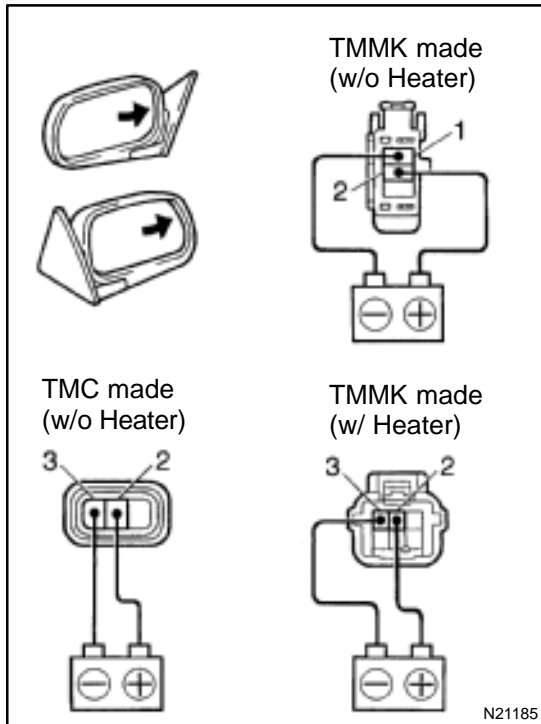

(d) Reverse the polarity and check that the mirror turns to right side.

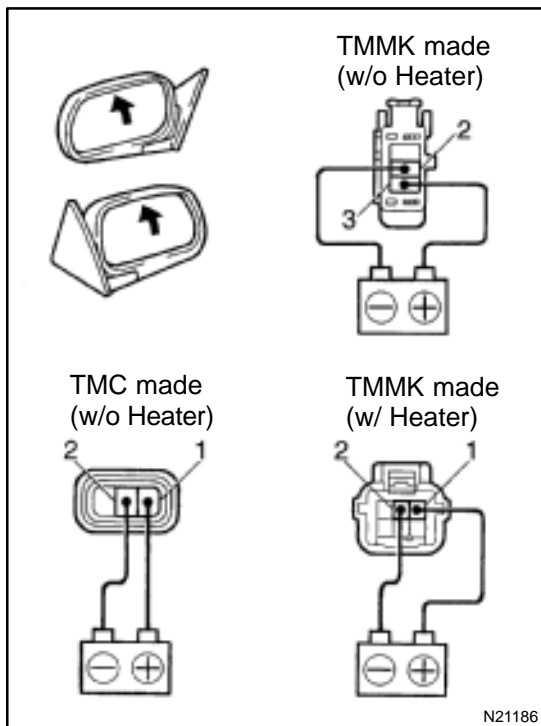

- (e) TMMK made (w/o Heater):
Connect the positive (+) lead from the battery to terminal 3 and the negative (-) lead to terminal 2, check that the mirror turns upward.
- (f) TMC made (w/o Heater):
Connect the positive (+) lead from the battery to terminal 1 and the negative (-) lead to terminal 2, check that the mirror turns upward.
- (g) TMMK made (w/ Heater):
Connect the positive (+) lead from the battery to terminal 1 and the negative (-) lead to terminal 2, check that the mirror turns upward.

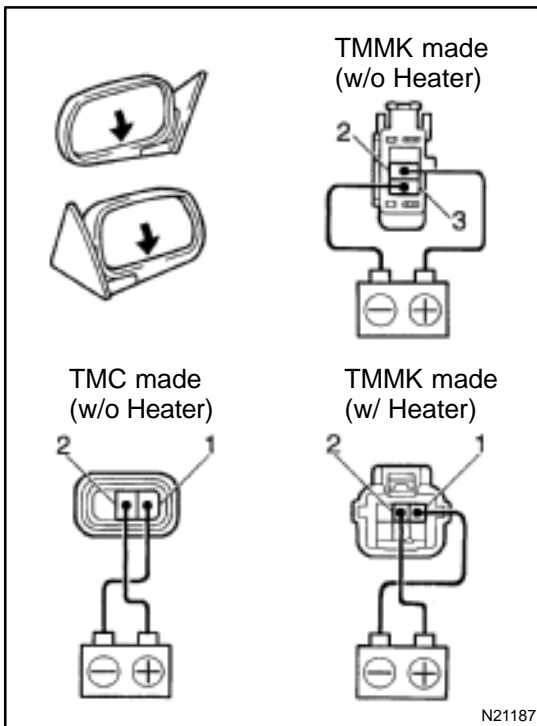

(h) Reverse the polarity, check that the mirror turns downward.
 If operation is not as specified, replace the mirror assembly.

AUDIO SYSTEM DESCRIPTION

BE0AX-03

1. RADIO WAVE BAND

The radio wave bands used in radio broadcasting are as follows:

Frequency	30 kHz	300 kHz	3 MHz	30 MHz	300 MHz
Designation	LF	MF	HF	VHF	
Radio wave		AM ↔		FM ↔	
Modulation method	Amplitude modulation			Frequency modulation	

LF: Low frequency MF: Medium Frequency HF: High Frequency VHF: Very High Frequency

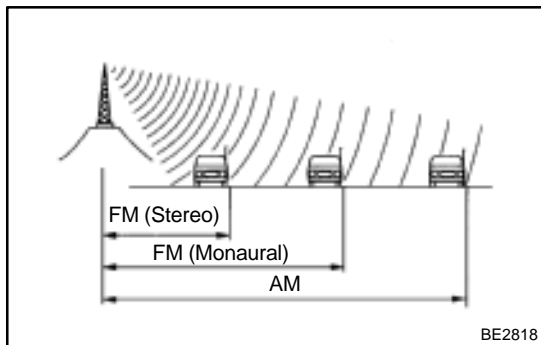

2. SERVICE AREA

There are great differences in the size of the service area for AM and FM monaural. Sometimes FM stereo broadcasts cannot be received even though AM comes in very clearly.

Not only does FM stereo have the smallest service area, but it also picks up static and other types of interference ("noise") easily.

3. RECEPTION PROBLEMS

Besides the problem of static, there are also the problems called "fading", "multipath" and "fade out". These problems are caused not by electrical noise but by the nature of the radio waves themselves.

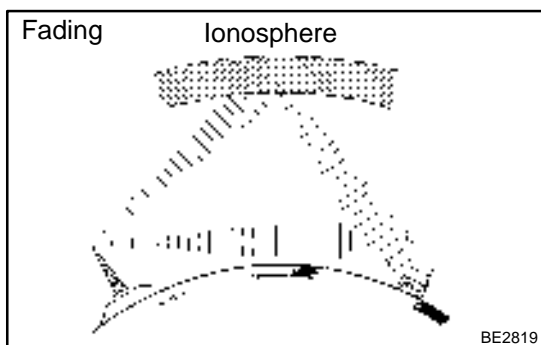

- Fading**
 Besides electrical interference, AM broadcasts are also susceptible to other types of interference, especially at night. This is because AM radio waves bounce off the ionosphere at night. These radio waves then interfere with the signals from the same transmitter that reach the vehicle's antenna directly. This type of interference is called "fading".

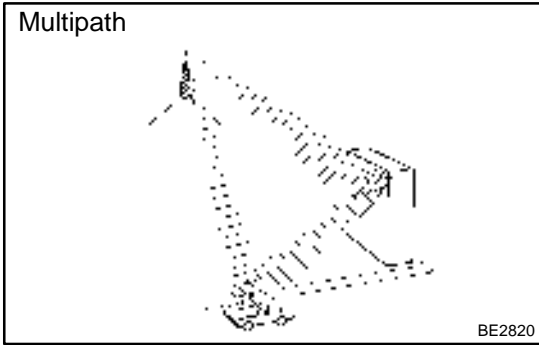

- **Multipath**
One type of interference caused by bouncing of radio waves off obstructions is called "multipath". Multipath occurs when a signal from the broadcast transmitter antenna bounces off buildings and mountains and interferes with the signal that is received directly.

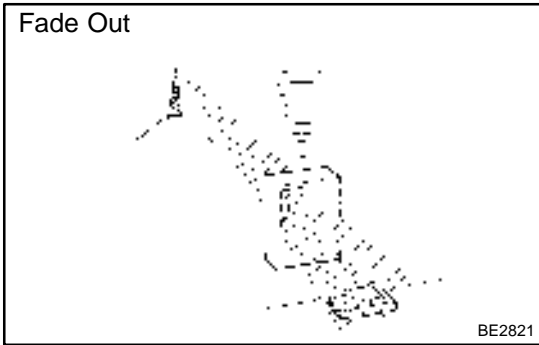

- **Fade Out**
Because FM radio waves are of higher frequencies than AM radio waves, they bounce off buildings, mountains, and other obstructions. For this reason, FM signals often seem to gradually disappear or fade away as the vehicle goes behind a building or other obstructions. This is called "fade out".

4. NOISE PROBLEMS

(a) Questionnaire for noise:

It is very important for noise troubleshooting to have good understanding of the claims from the customers, so that make the best use of following questionnaire and diagnose the problem accurately.

AM	Noise occurs at a specific place.	Strong possibility of foreign noise.
	Noise occurs when listening to faint broadcasting.	There is a case that the same program is broadcasted from each local station and that may be the case you are listening to different station if the program is the same.
	Noise occurs only at night.	Strong possibility of the beat from a distant broadcasting.
FM	Noise occurs while driving and at a specific place.	Strong possibility of multipath noise and fading noise caused by the changes of FM waves.

HINT:

In the case that the noise occurrence condition does not meet any of the above questionnaire, check based on the "Trouble Phenomenon".

Refer to previous page for multipath and fading.

- (b) Matlers that require attention when checking:
- Noise coming into the radio usually has no harm for practical use as the noise protection is taken and it is hardly thinkable for an extremely loud noise to come in. When extremely loud noise comes into the radio, check if the grounding is normal where the antenna is installed.
 - Check if all the regular noise prevention parts are properly installed and if there is any installation of non–authorized parts and non–authorized wiring.
 - If you leave the radio out of tune (not tuning), it is easy to diagnose the phenomenon as noise occurs frequently.

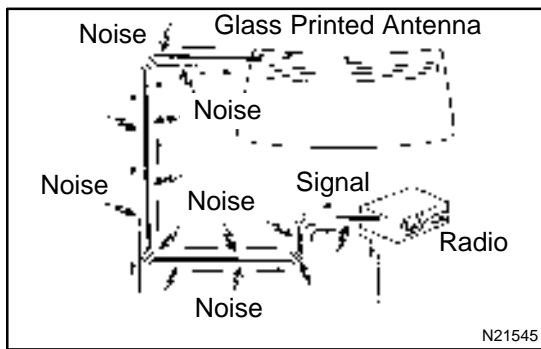

- (c) Antenna and noise:
 Electronic signal received by the antenna will reach to the radio transmitting through the core wire of the coaxial cable. Any noise wave other than radio wave is mixed into this core wire, that naturally causes noise in the radio and poor sound quality. In order to prevent these noises from mixing into the radio, the core wire inside the coaxial cable is covered with a mesh wire called shield wire. This shield wire shelters the noise and transmits it to the ground, thus preventing noise from mixing in. If this shield wire has grounding failure, that causes noise.

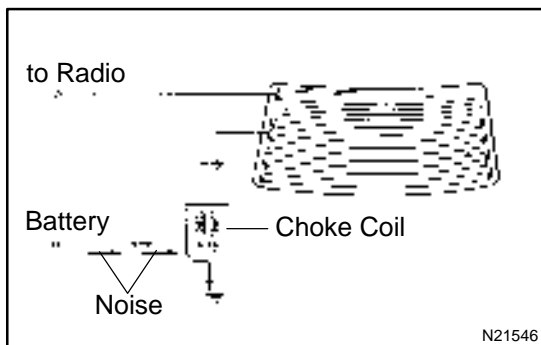

- (d) Choke coil and noise:
 The choke coil is connected in the rear window defogger circuit. This is conneted so to prevent noise from mixing into the radio by making the noise current included in the power source of the rear window defogger flow to the ground.

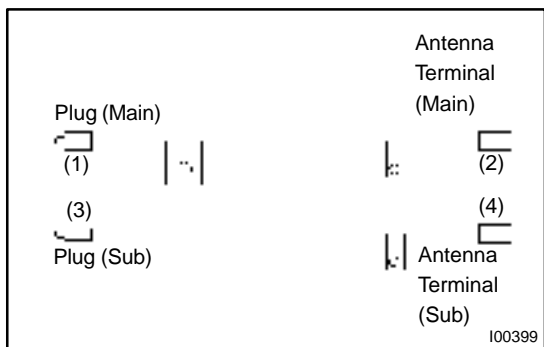

**5. Glass printed antenna:
GROUNDING FOR THE ANTENNA CORD AND CHOKE COIL**

HINT:
During troubleshooting, in case that the antenna code continuity check, grounding check and grounding check of the choke coil are needed, please check referring to the following illustration.

Terminal connection	Normal condition
(1) ↔ (2)	Continuity
(3) ↔ (4)	Continuity

Ground point:

Antenna Cord

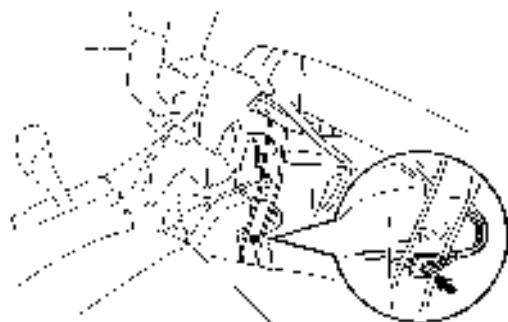

Center Brace

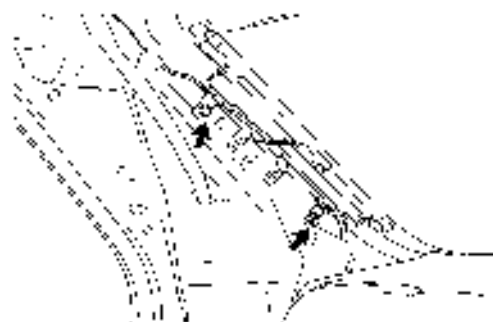

Pillar (RH)

Choke Coil

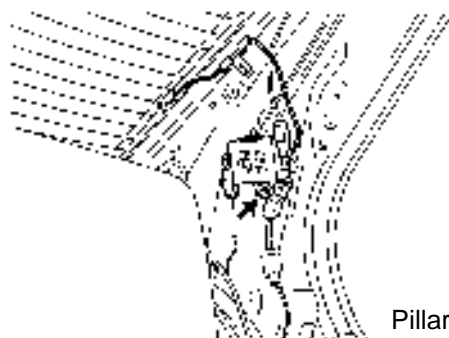

Pillar (LH)

N21548 I00402
I00403

I00407

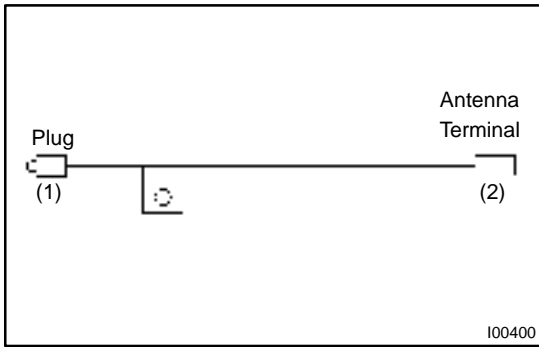

**6. Fixed mast antenna:
GROUNDING FOR THE ANTENNA CORD AND CHOKE
COIL**

HINT:

During troubleshooting, in case that the antenna code continuity check, grounding check and grounding check of the choke coil are needed, please check referring to the following illustrations.

Terminal connection	Normal condition
(1) ↔ (2)	Continuity

Ground point:

Antenna Cord

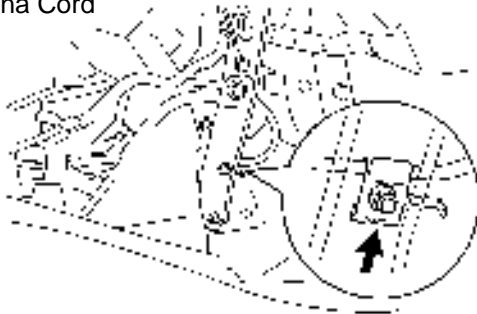

Center Brace

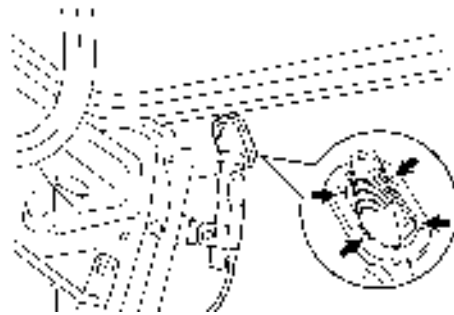

Luggage Room (RH side)

Noise Filter

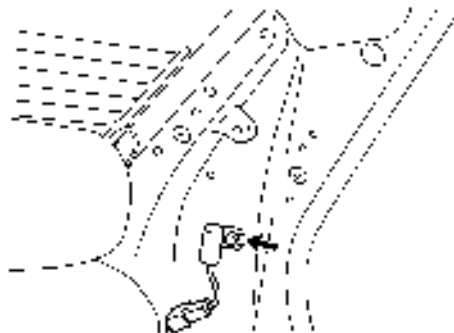

Pillar (LH)

I00427 I00428
I00429

I00408

TROUBLESHOOTING

NOTICE:

When replacing the internal mechanism (computer part) of the audio system, be careful that no part of your body or clothing comes in contact with the terminals of the leads from the IC, etc. of the replacement part (spare part).

HINT:

This inspection procedure is a simple troubleshooting which should be carried out on the vehicle during system operation and was prepared on the assumption of system component troubles (except for the wires and connectors, etc.).

Always inspect the trouble taking the following items into consideration.

Open or short circuit of the wire harness

Connector or terminal connection fault

	Problem	No.
Radio	Radio not operating when power switch turned 'ON'.	1
	Display indicates when power switch turned 'ON', but no sound (including 'noise') is produced.	2
	Noise present, but AM – FM not operating.	3
	Any speaker does not work.	4
	Either AM or FM does not work, reception poor (volume faint), Fewer station pre-sets.	5
	Poor reception.	6
	Sound quality poor.	7
	Preset memory disappears.	8
Tape Player	Cassette tape cannot be inserted.	9
	Cassette tape is inserted, but no power.	10
	Power coming in, but tape player not operating.	11
	Either speaker does not work.	12
	Sound quality poor. (volume faint)	13
	Tape jammed, malfunction with tape speed or auto–reverse.	14
	Cassette tape will not be ejected.	15
CD Player	CD cannot be inserted.	16
	CD inserted, but no power.	17
	Power coming in, but CD player not operating.	18
	Sound jumps.	19
	Sound quality poor (Volume faint).	20
	Either speaker does not work.	21
	CD will not be ejected.	22
Noise	Noise occurs.	23
	Noise produced by vibration or shock while driving.	24
	Noise produced when engine starts.	25

The term "AM" includes LW, MW and SW, and the term "FM" includes UKW.

1	Radio	RADIO NOT OPERATING WHEN POWER SWITCH TURNED 'ON'
---	-------	--

- Radio-CD Plater Unit (Built-in Power Amplifier)
- Radio-Tape Plater Unit (Built-in Power Amplifier)

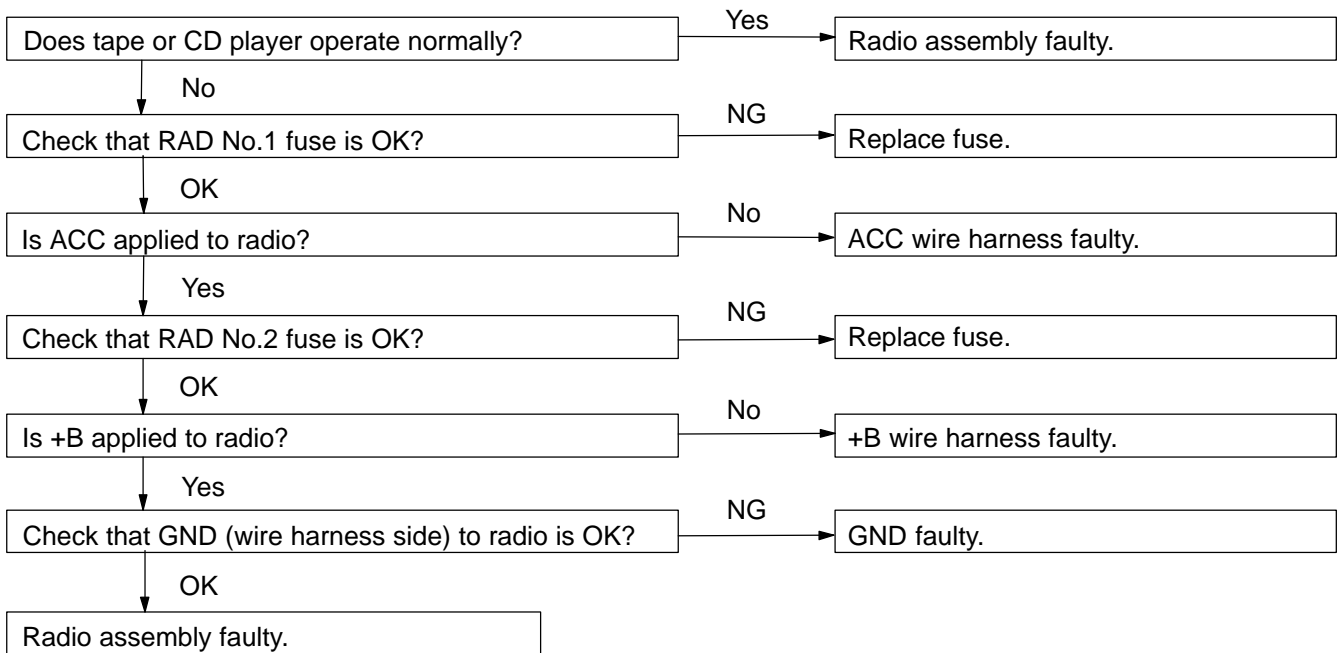

- Radio-Tape Player Unit (Separate Power Amplifier)
- Radio-Tape Player-CD Player Unit (Separate Power Amplifier)
- Radio-CD Player Unit (Separate Power Amplifier)

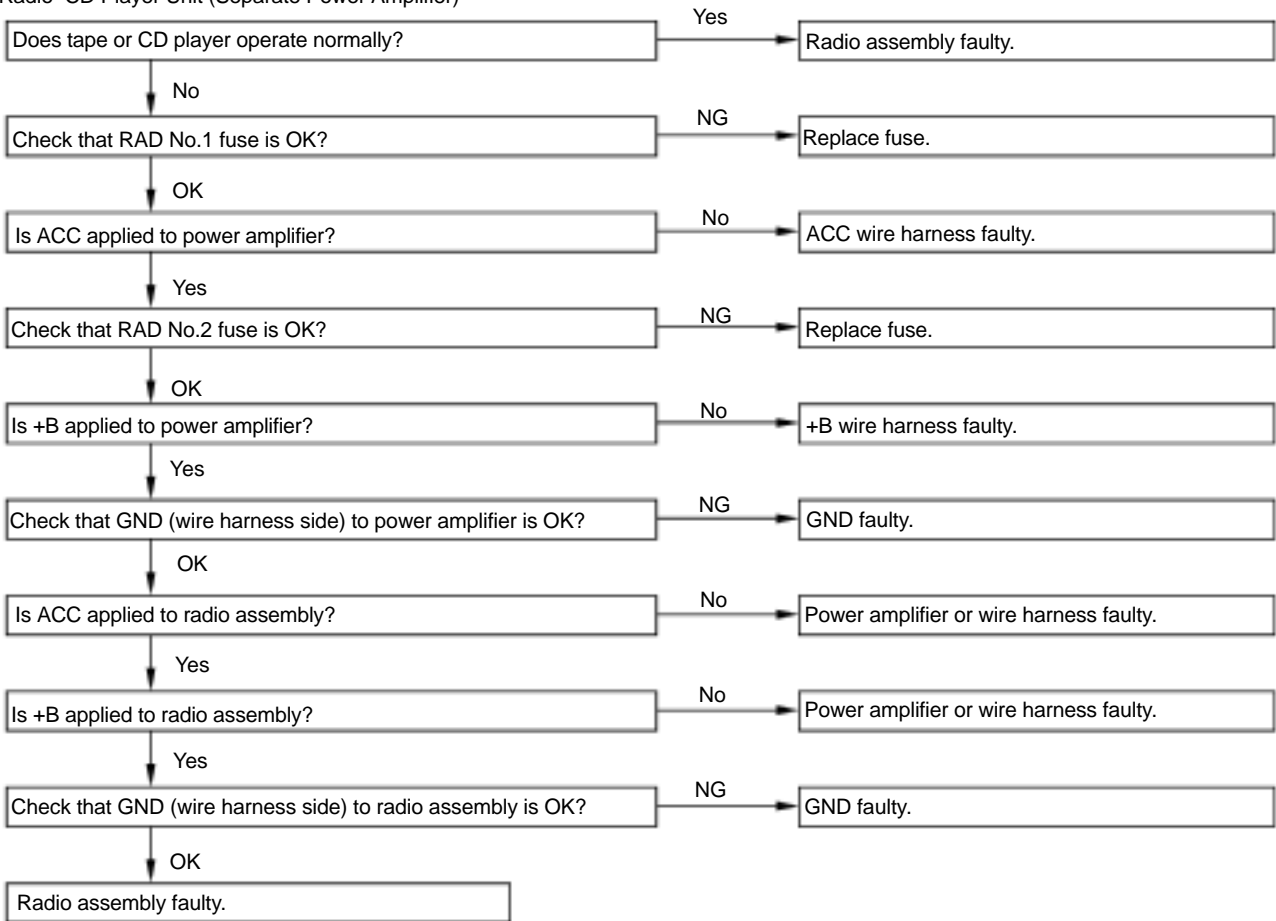

I03349

2	Radio	DISPLAY INDICATES WHEN POWER SWITCH TURNED 'ON', BUT NO SOUND (INCLUDING 'NOISE') IS PRODUCED
---	-------	--

- Radio-Tape Player Unit (Built-in Power Amplifier)
- Radio-CD Player Unit (Built-in Power Amplifier)

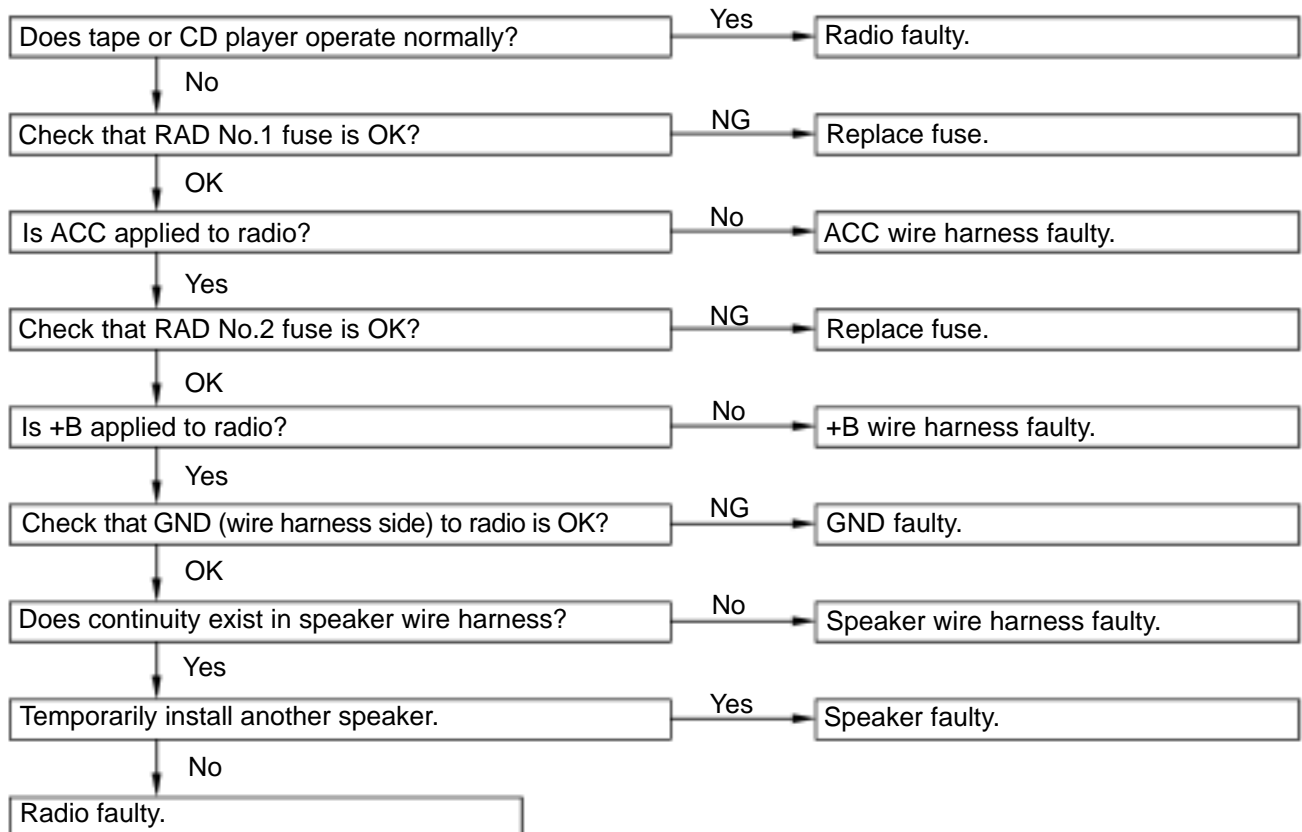

I03350

- Radio-Tape Player Unit (Separate Power Amplifier)
- Radio-Tape Player-CD Player Unit (Separate Power Amplifier)
- Radio-CD Player Unit (Separate Power Amplifier)

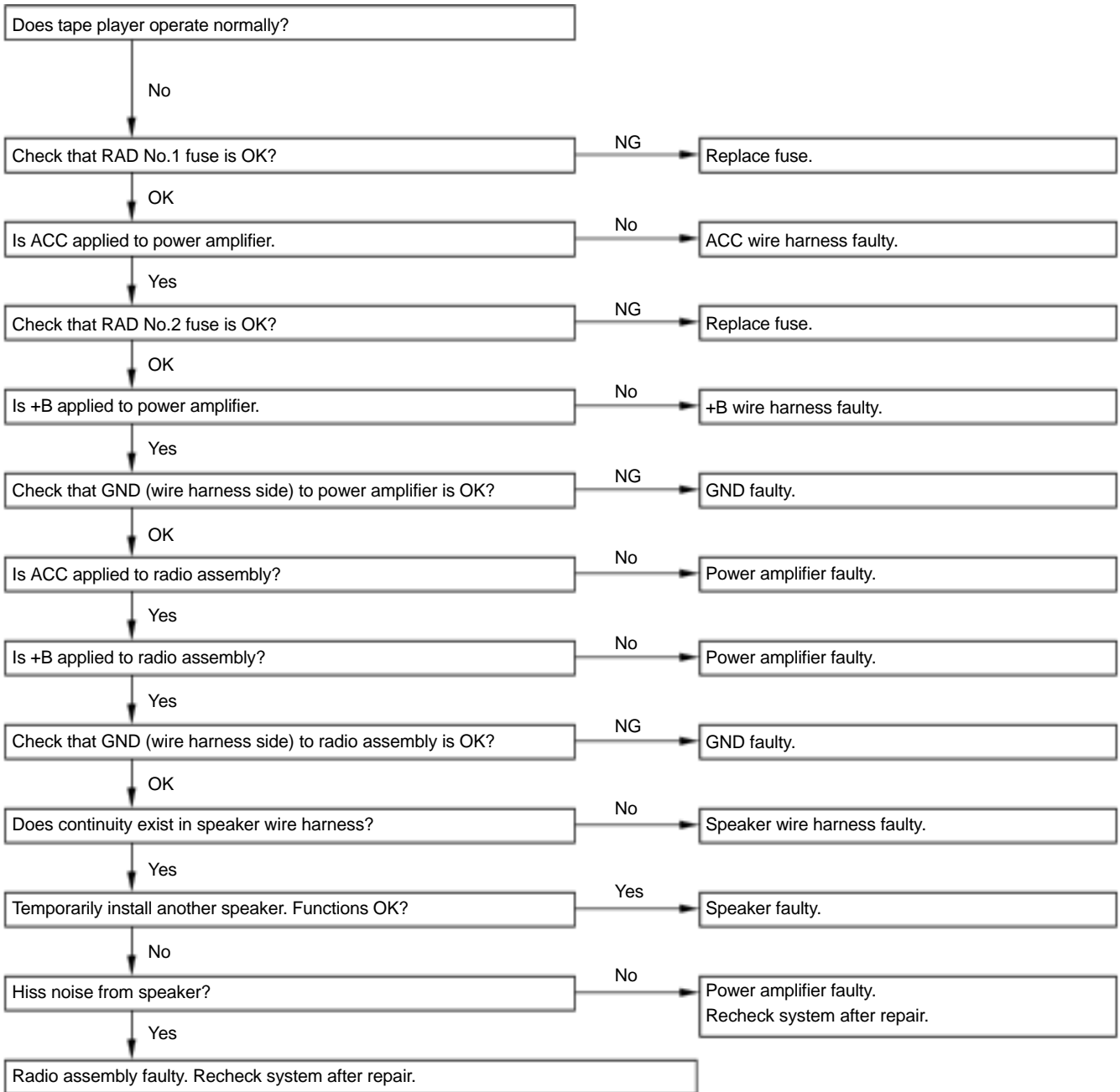

V08239

3	Radio	NOISE PRESENT, BUT AM-FM NOT OPERATING
----------	--------------	---

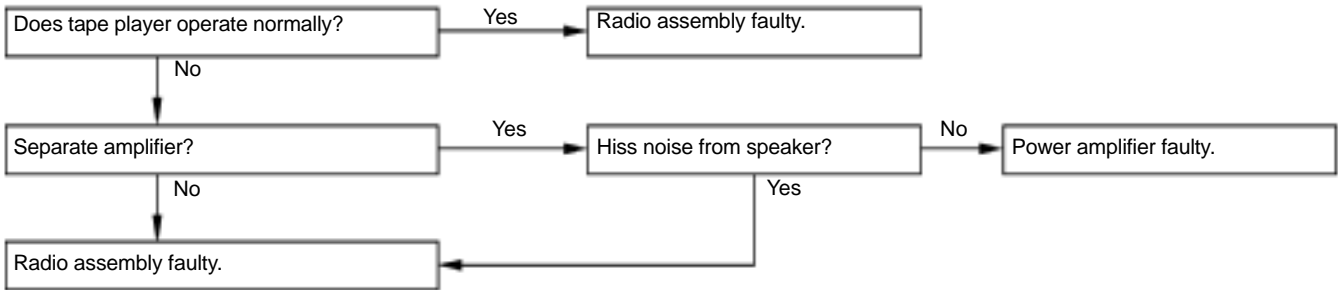

4	Radio	ANY SPEAKER DOSE NOT WORK
----------	--------------	----------------------------------

- Radio-Tape Player Unit (Built-in Power Amplifier)
- Radio-CD Player Unit (Built-in Power Amplifier)

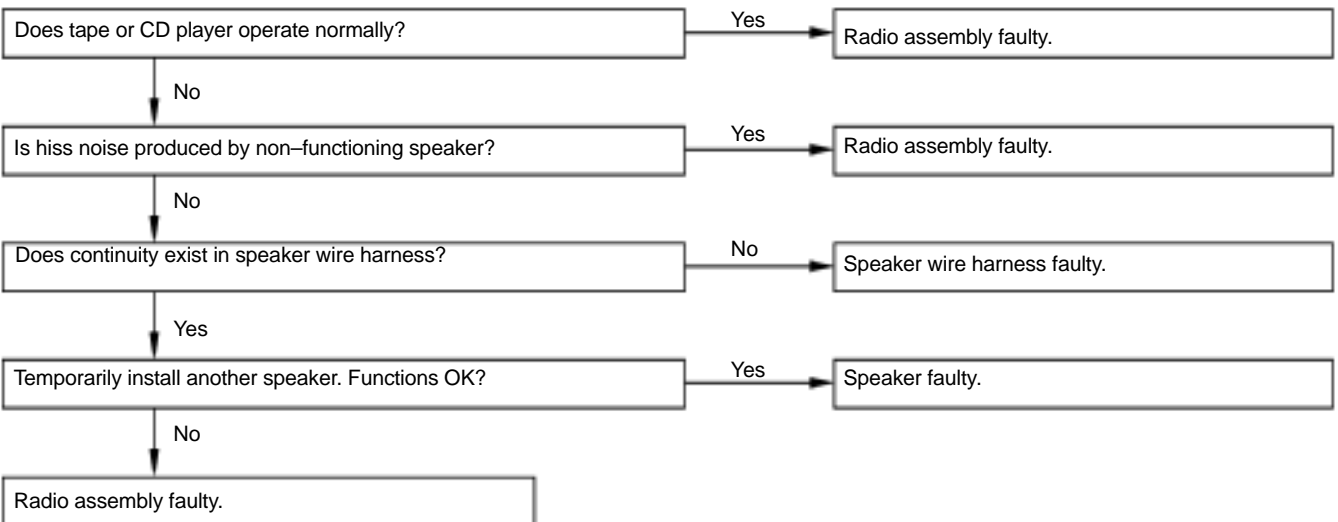

- Radio-Tape Player Unit (Separate Power Amplifier)
- Radio-Tape Player-CD Player Unit (Separate Power Amplifier)
- Radio-CD Player Unit (Separate Power Amplifier)

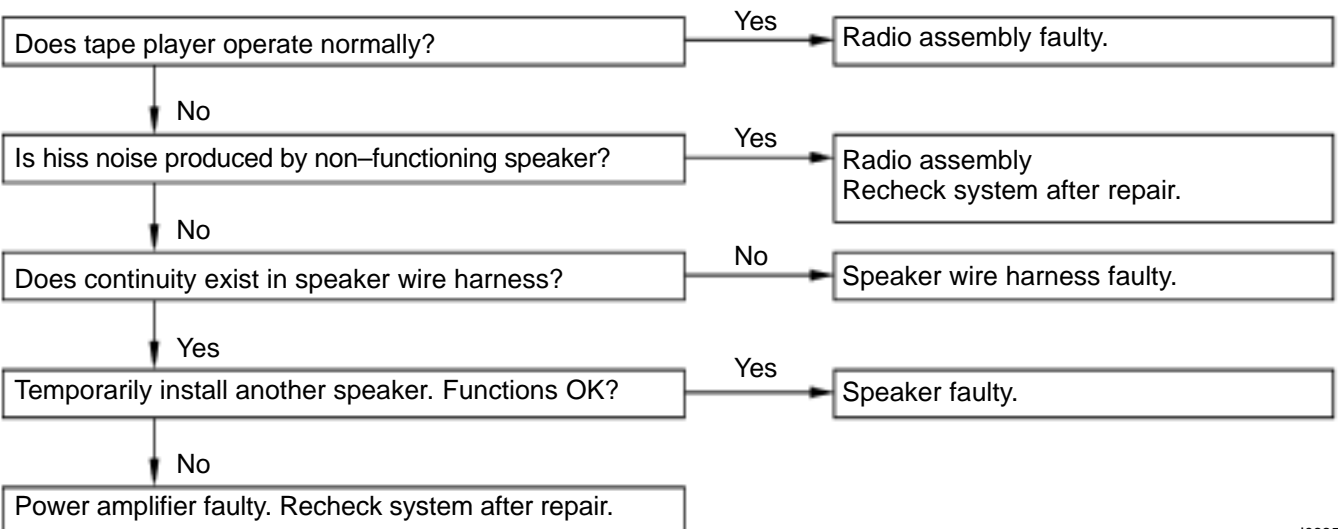

5	Radio	EITHER AM OR FM DOES NOT WORK, RECEPTION POOR (VOLUME FAINT), FEWER STATION PRESETS
----------	--------------	--

- Radio-Tape Player Unit (Built-in Power Amplifier)
- Radio-CD Player Unit (Built-in Power Amplifier)

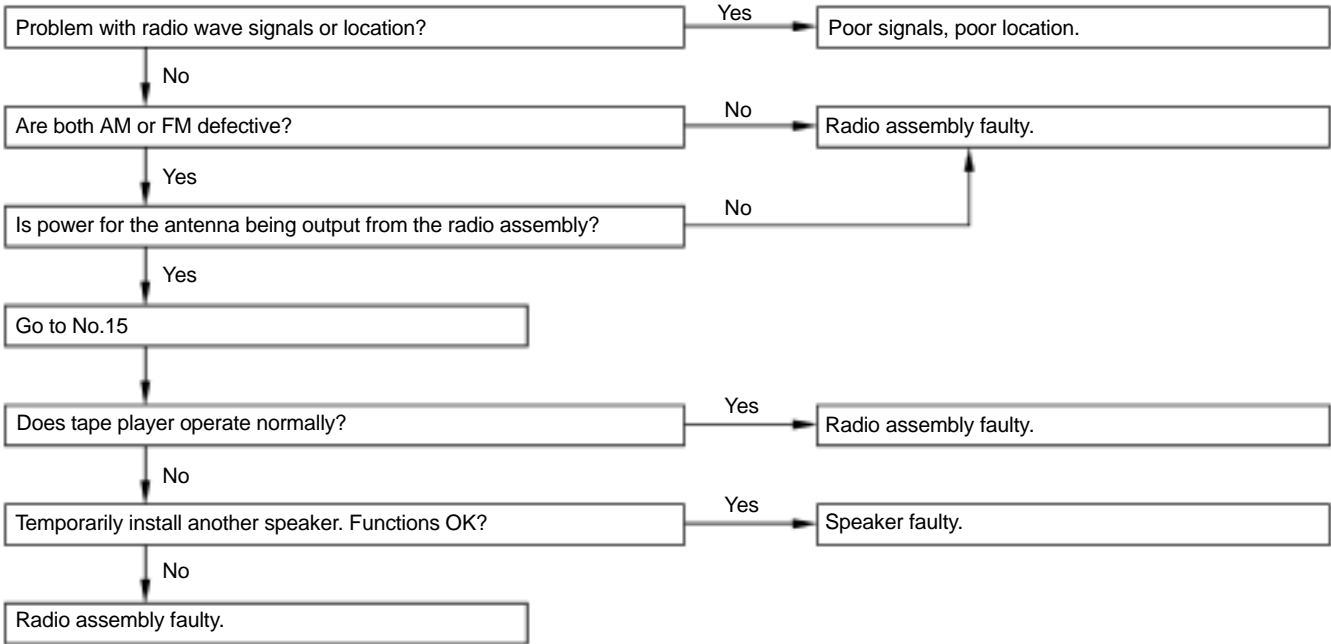

- Radio-Tape Player Unit (Separate Power Amplifier)
- Radio-Tape Player-CD Player Unit (Separate Power Amplifier)
- Radio-CD Player Unit (Separate Power Amplifier)

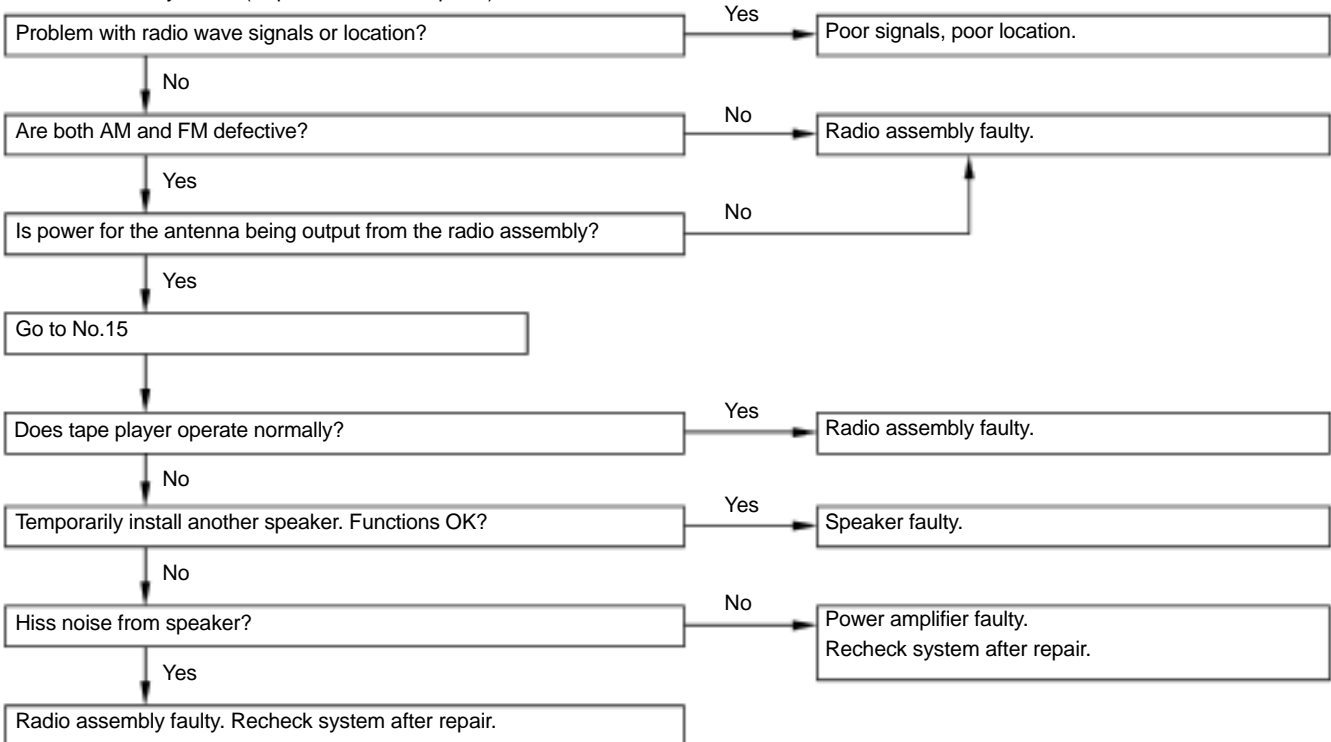

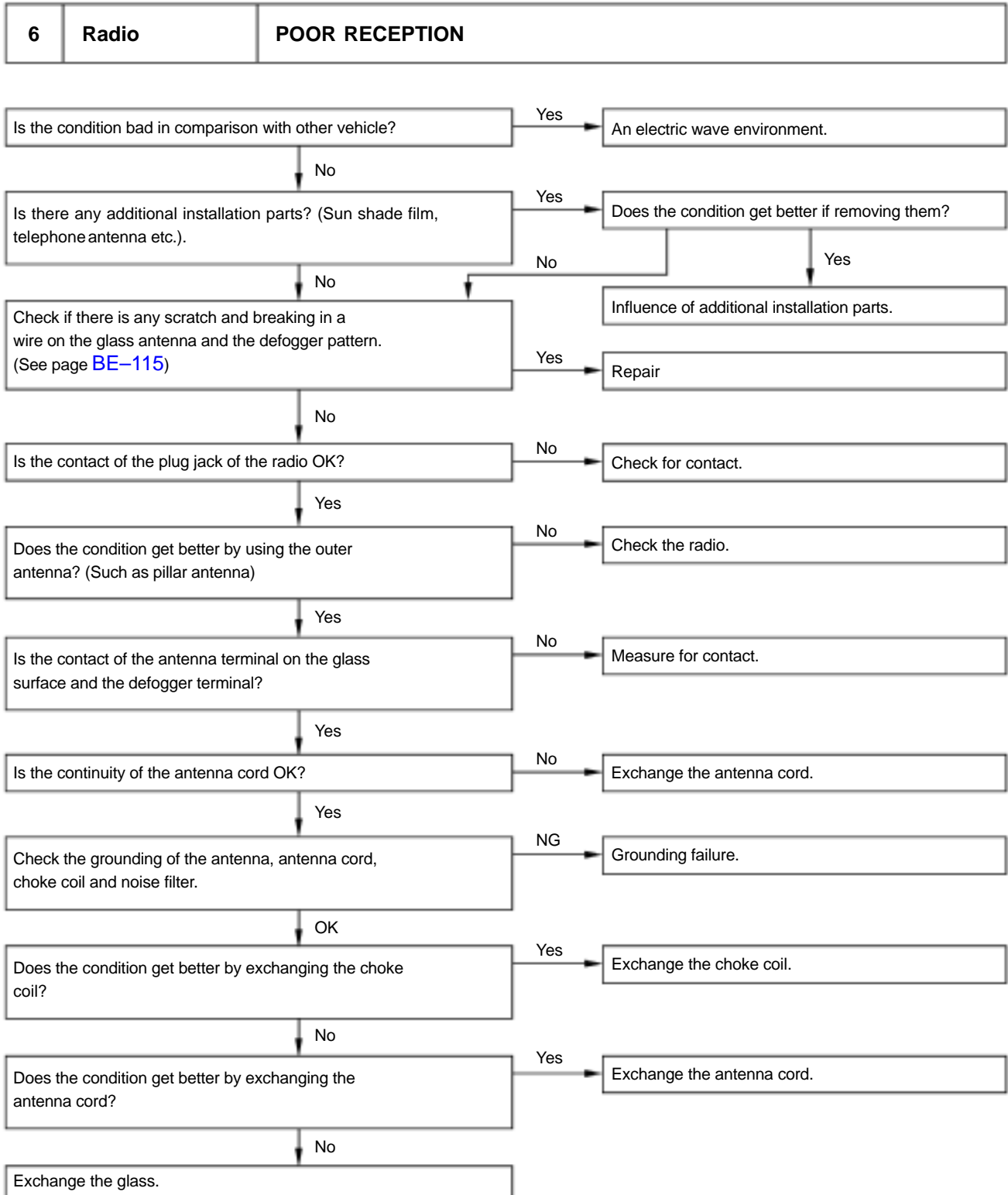

7	Radio	SOUND QUALITY POOR
----------	--------------	---------------------------

- Radio-Tape Player Unit (Built-in Power Amplifier)
- Radio-CD Player Unit (Built-in Power Amplifier)

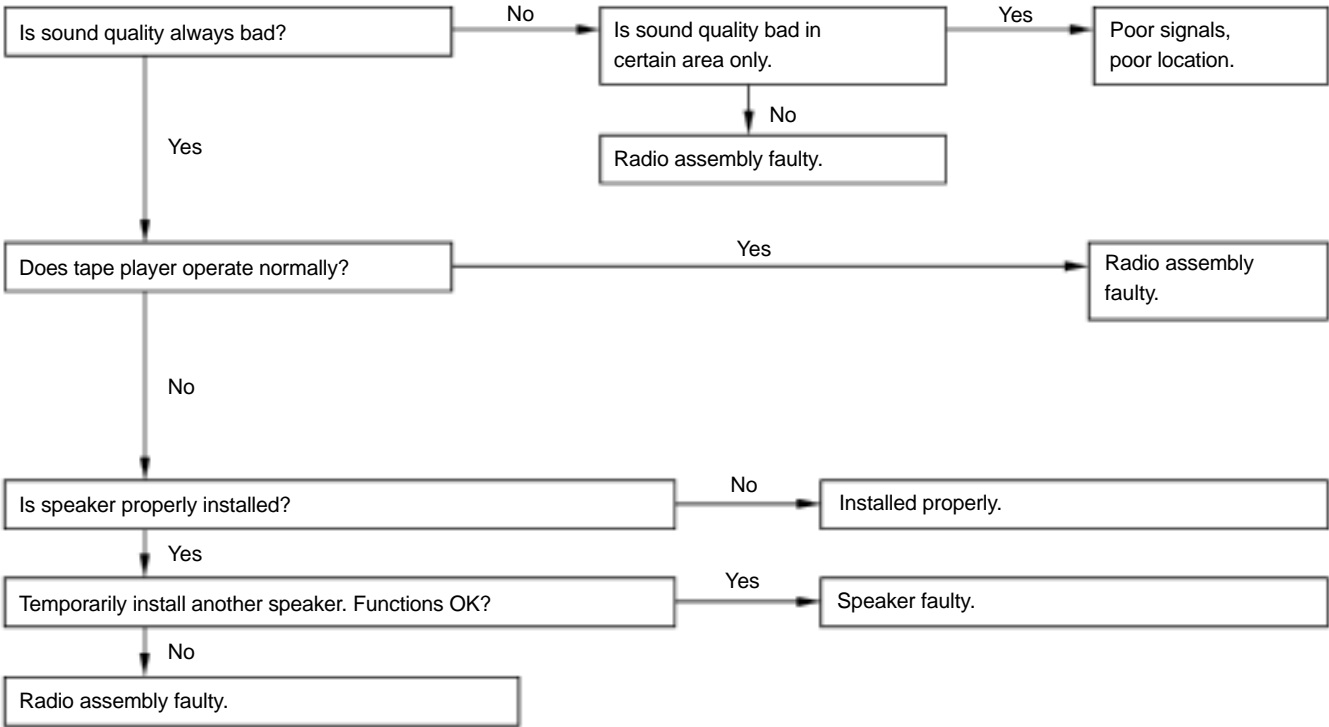

- Radio-Tape Player Unit (Separate Power Amplifier)
- Radio-Tape Player-CD Player Unit (Separate Power amplifier)
- Radio-Tape CD Unit (Separate Power Amplifier)

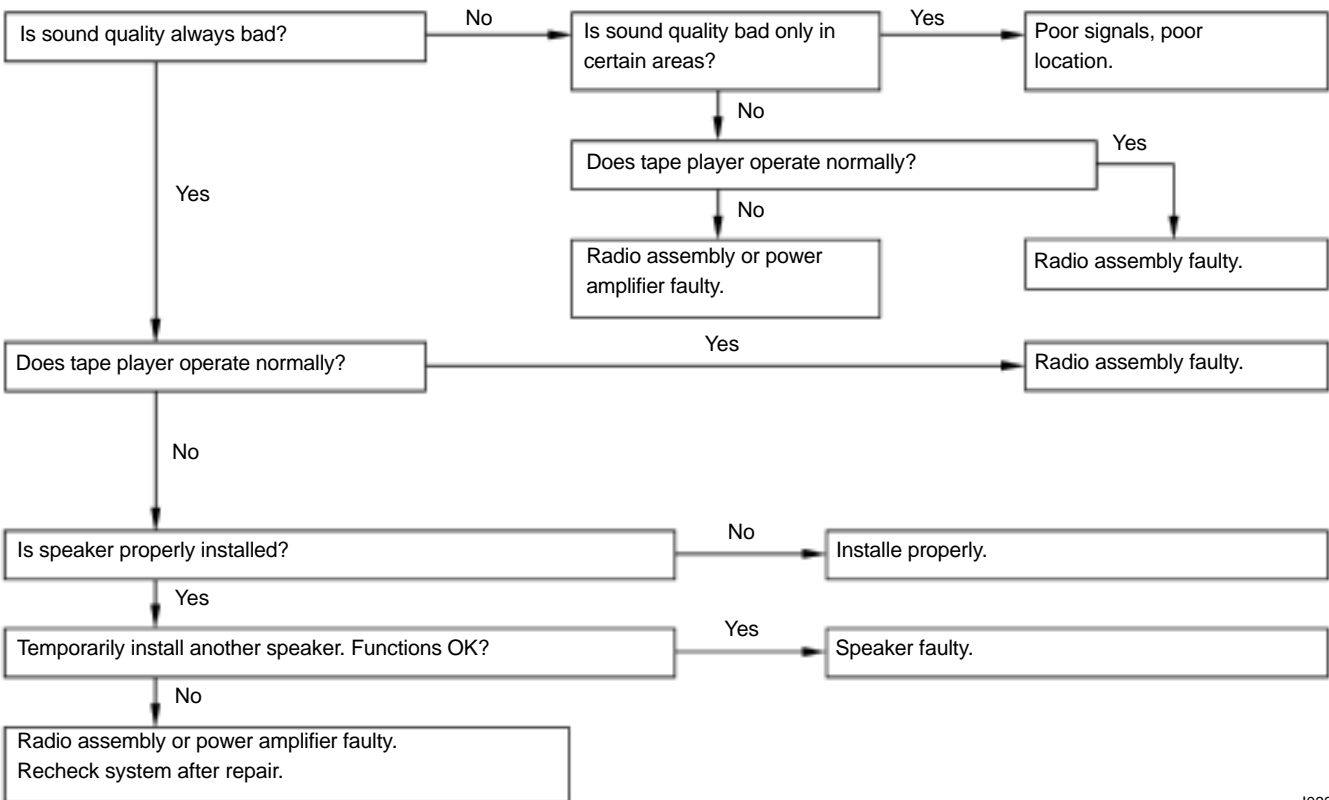

I03353

8	Radio	PRESET MEMORY DISAPPEARS
----------	--------------	---------------------------------

- Radio-Tape Player Unit (Built-in Power Amplifier)
- Radio-CD Player Unit (Built-in Power Amplifier)

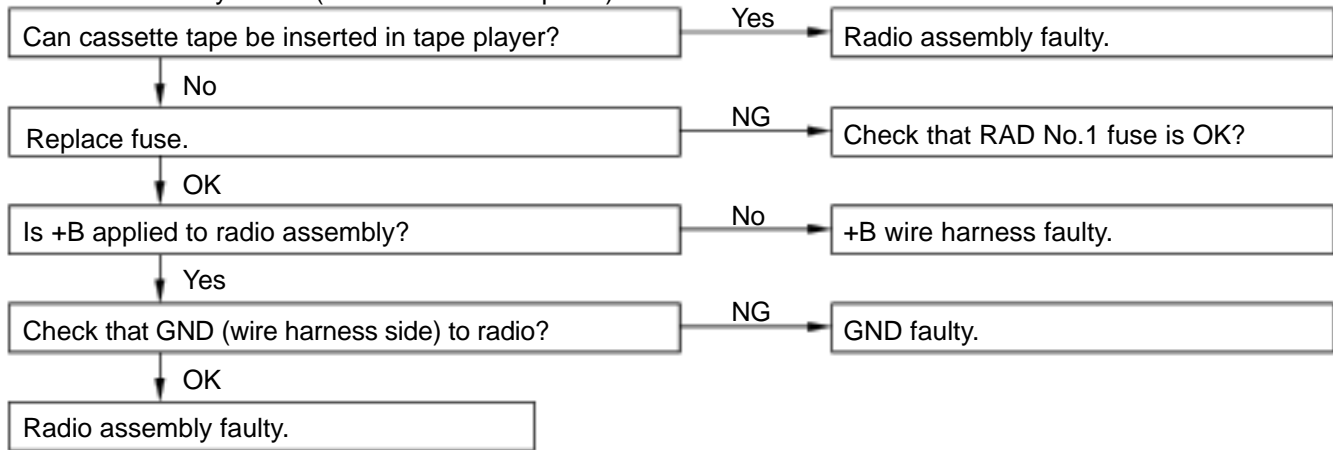

- Radio-Tape Player Unit (Separate Power Amplifier)
- Radio-Tape Player-CD Player Unit (Separate Power Amplifier)
- Radio-CD Player Unit (Separate Power Amplifier)

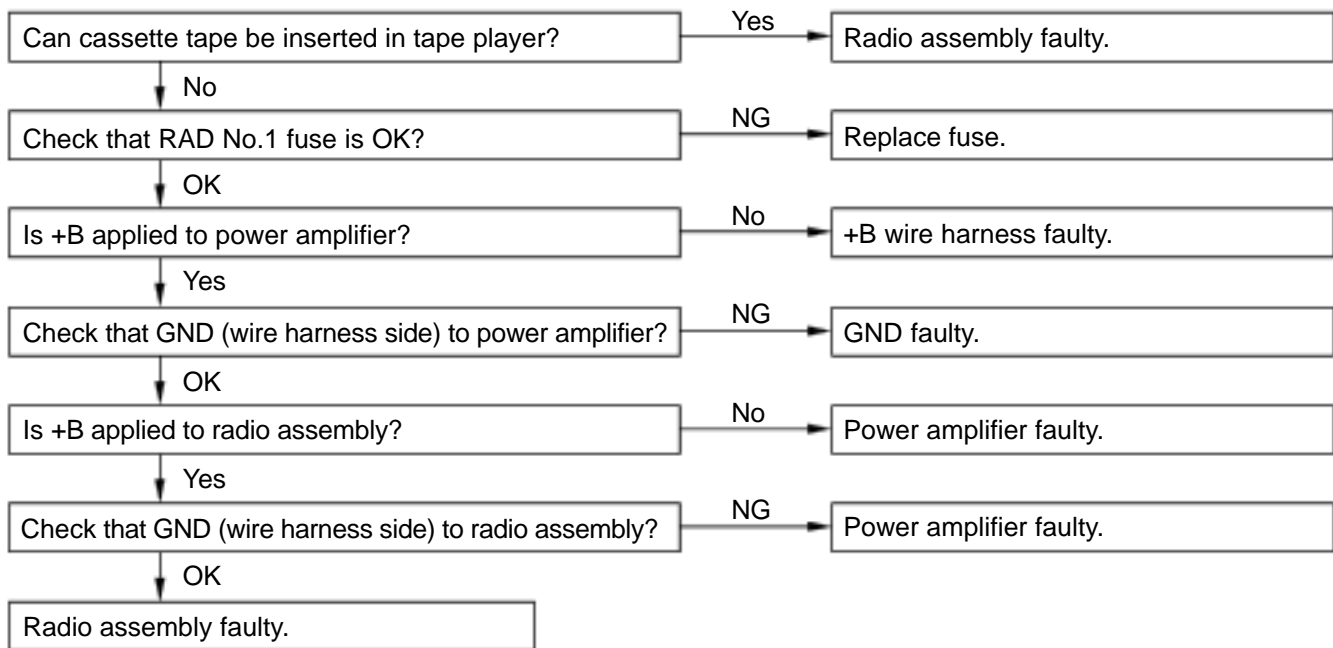

I03354

9	Tape Player	CASSETTE TAPE CANNOT BE INSERTED
----------	--------------------	---

• Radio-Tape Player Unit (Built-in Power Amplifier)

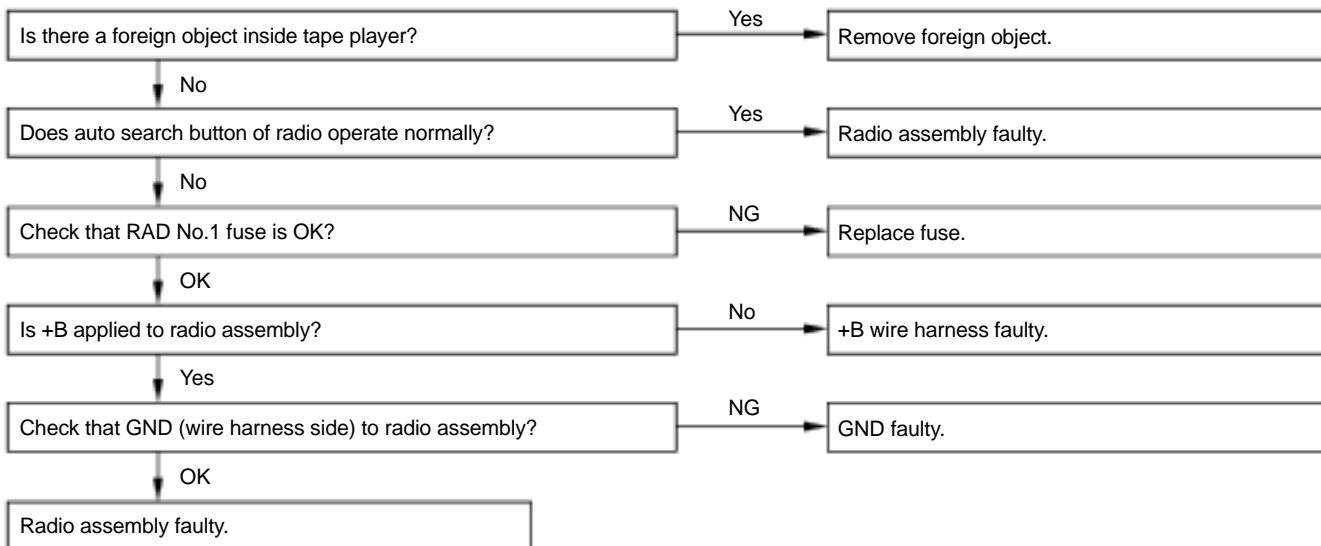

• Radio-Tape Player Unit (Separate Power Amplifier)

• Radio-Tape Player-CD Player Unit (Separate Power Amplifier)

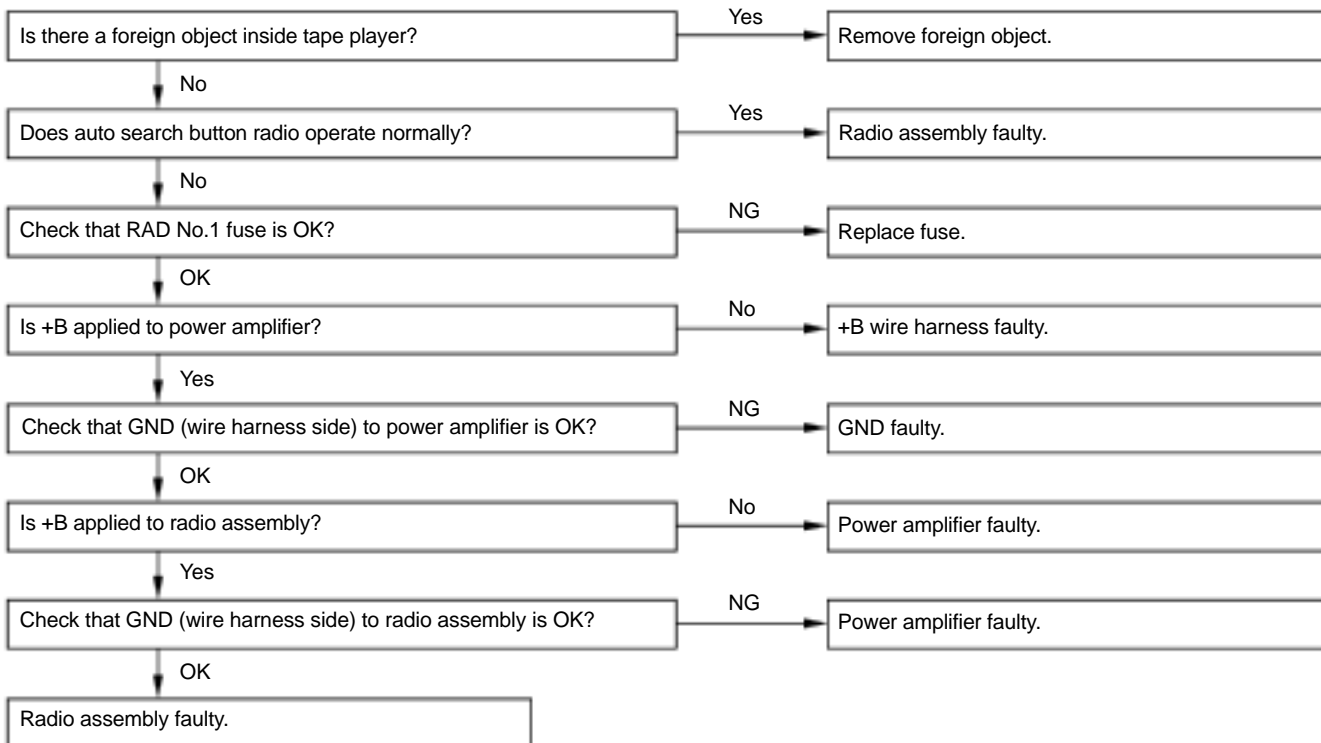

V08246

10	Tape Player	CASSETTE TAPE IS INSERTED, BUT NO POWER
-----------	--------------------	--

• Radio-Tape Player Unit (Built-in Power Amplifier)

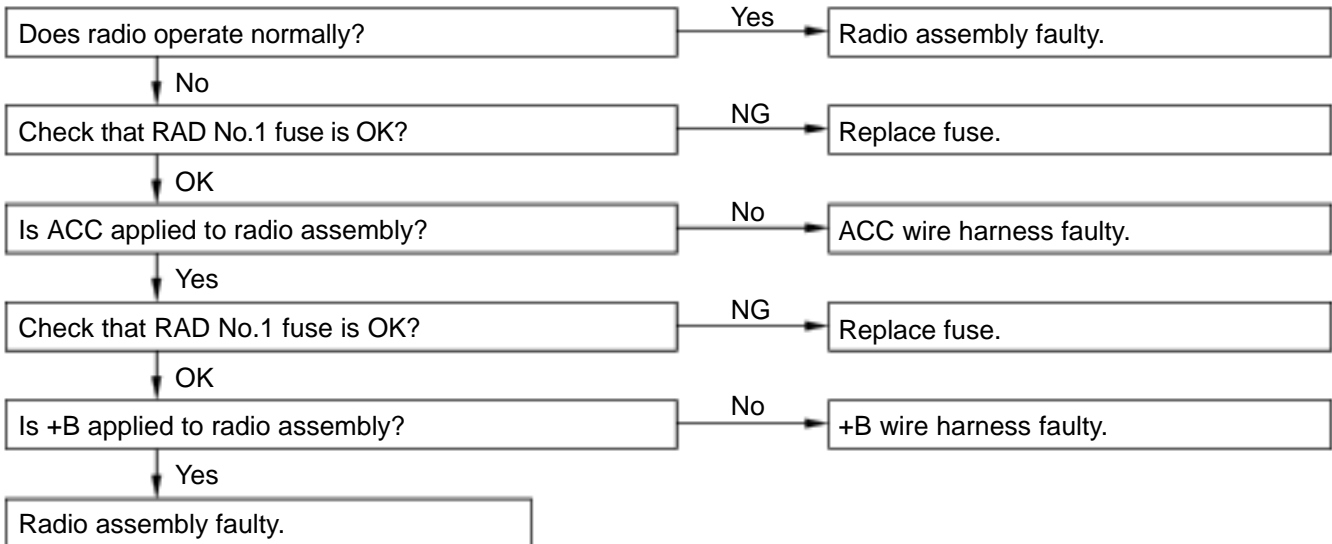

- Radio-Tape Player Unit (Separate Power Amplifier)
- Radio-Tape Player-CD Player Unit (Separate Power Amplifier)

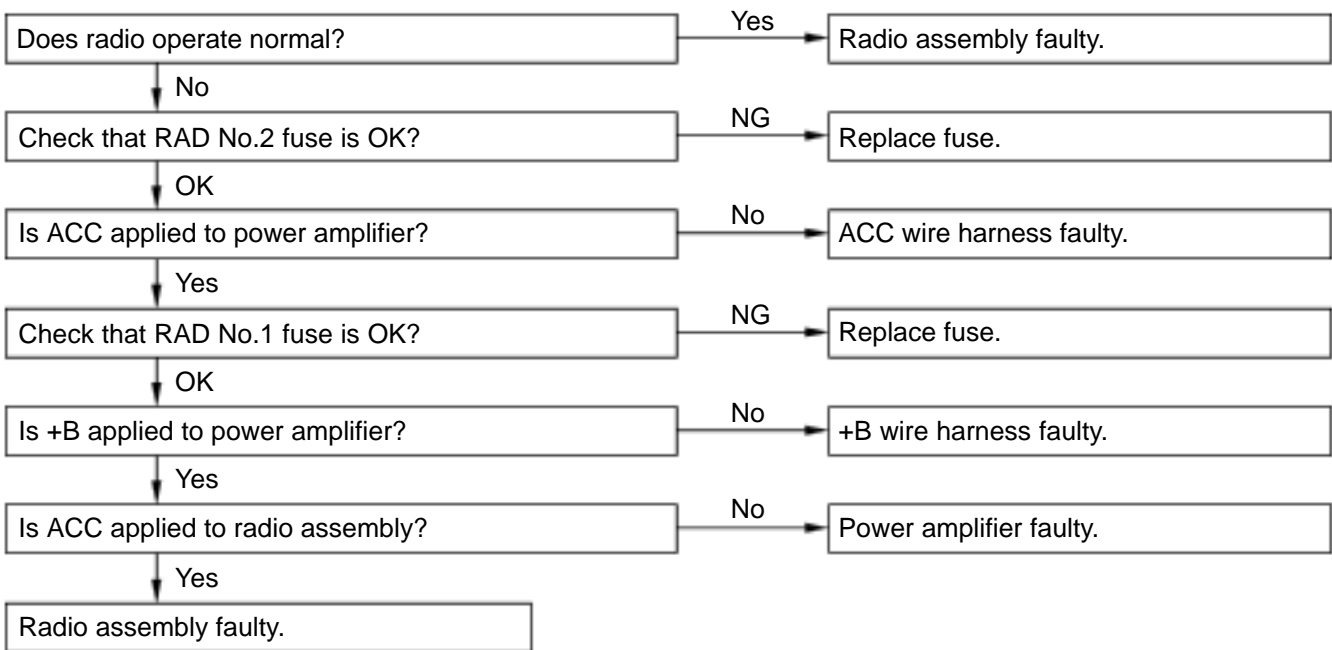

11	Tape Player	POWER COMING IN, BUT TAPE PLAYER NOT OPERATING
-----------	--------------------	---

● Radio-Tape Player Unit (Built-in Power Amplifier)

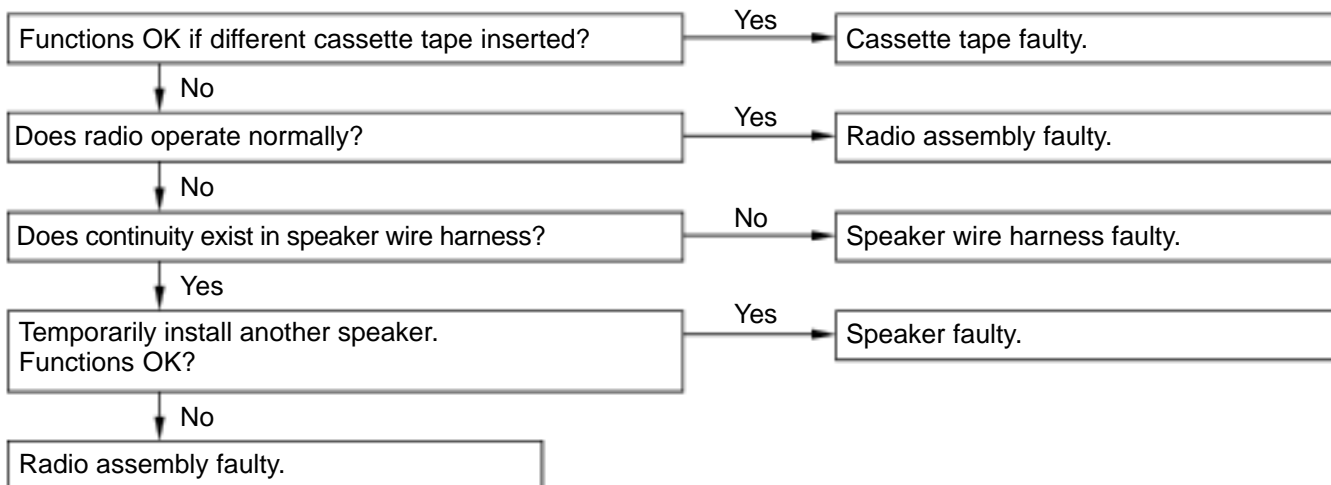

- Radio-Tape Player Unit (Separate Power Amplifier)
- Radio-Tape Player-CD Player Unit (Separate Power Amplifier)

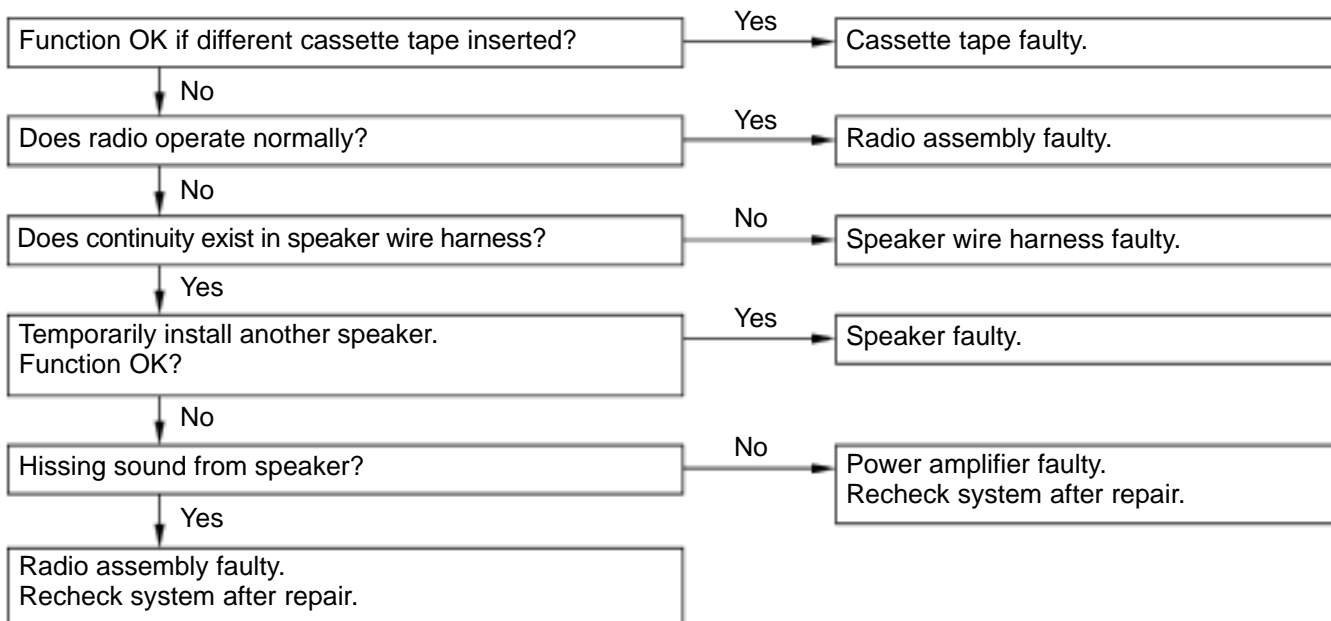

V08248

12	Tape Player	EITHER SPEAKER DOES NOT WORK
----	-------------	-------------------------------------

• Radio-Tape Player Unit (Built-in Power Amplifier)

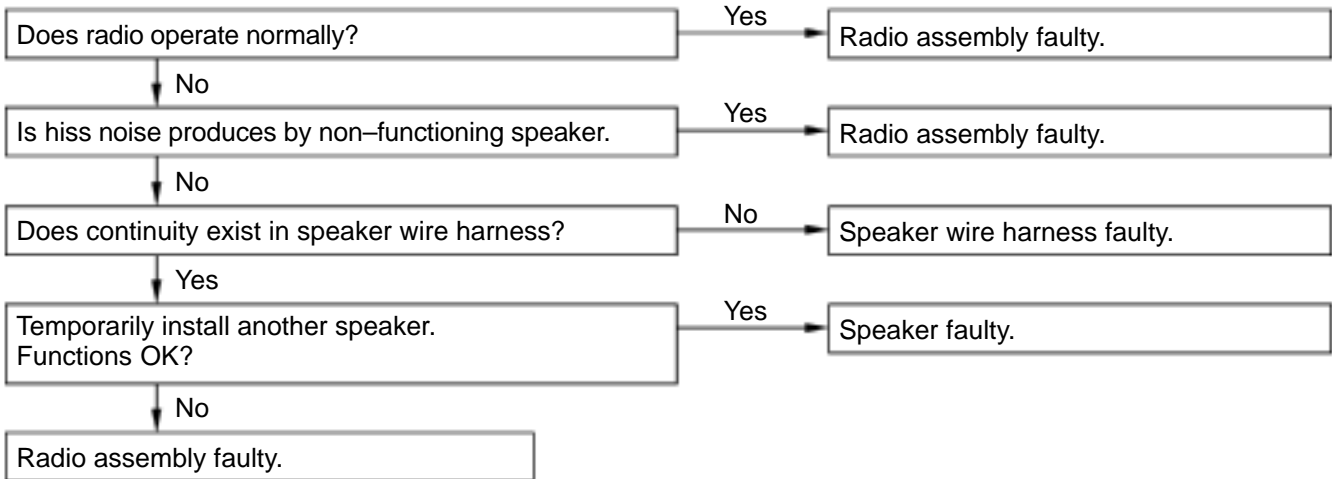

• Radio-Tape Player Unit (Separate Power Amplifier)
 • Radio-Tape Player-CD Player Unit (Separate Power Amplifier)

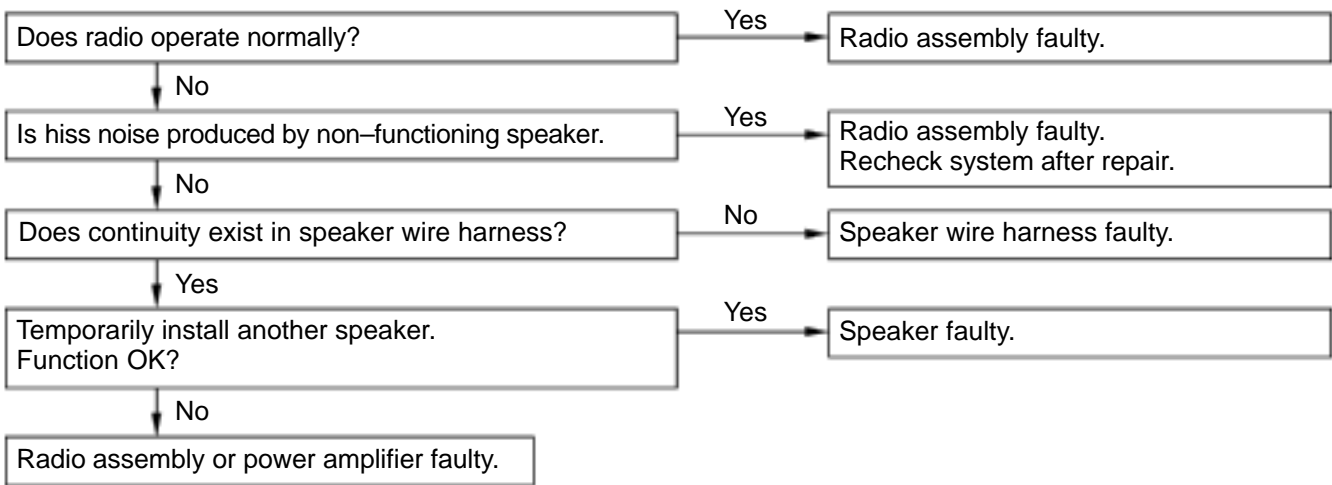

V08249

13	Tape Player	SOUND QUALITY POOR (VOLUME FAINT)
-----------	--------------------	--

- Radio-Tape Player Unit (Built-in Power Amplifier)

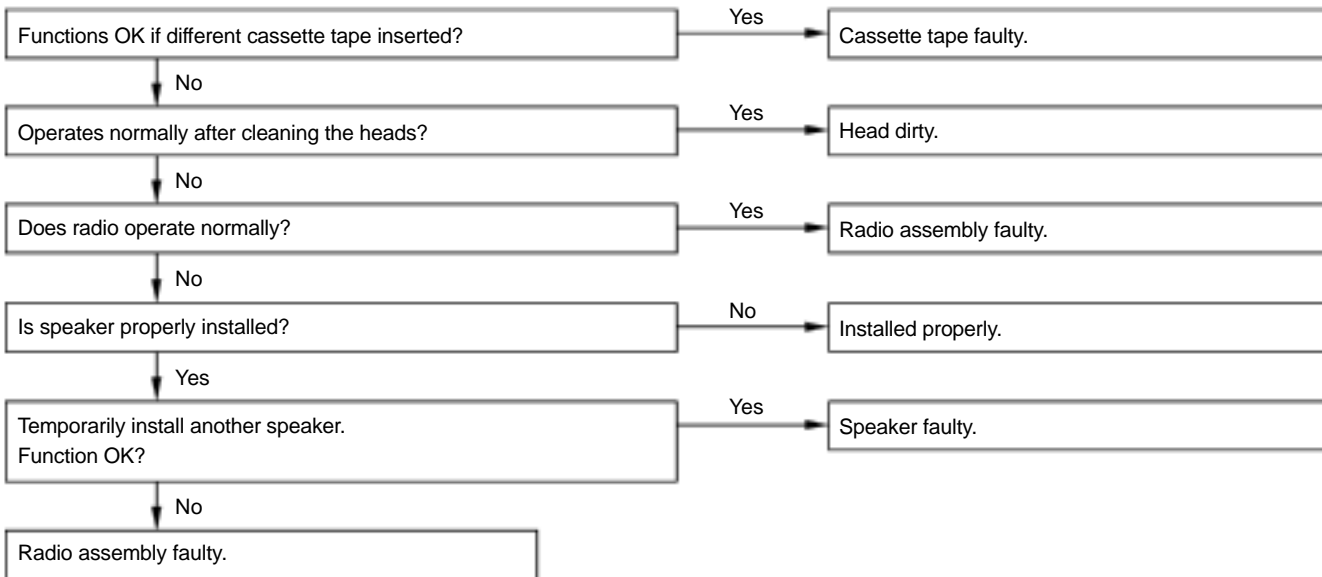

- Radio-Tape Player Unit (Separate Power Amplifier)
- Radio-Tape Player-CD Player Unit (Separate Power Amplifier)

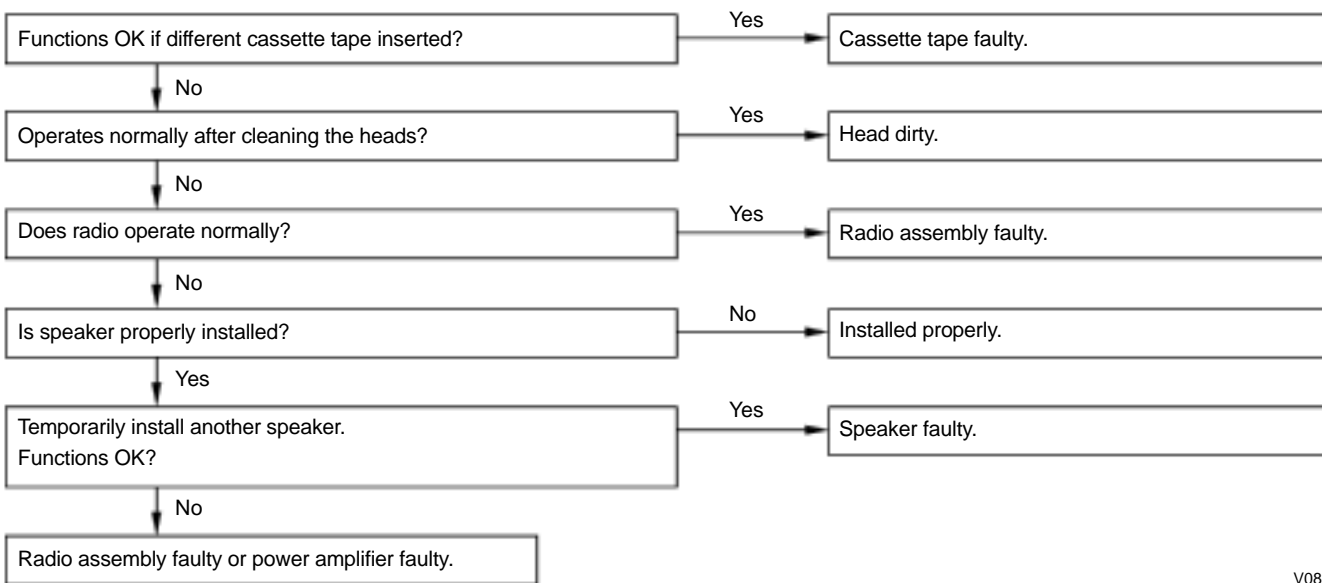

V08250

14	Tape Player	TAPE JAMMED, MALFUNCTION WITH TAPE SPEED OR AUTO-REVERSE
-----------	--------------------	---

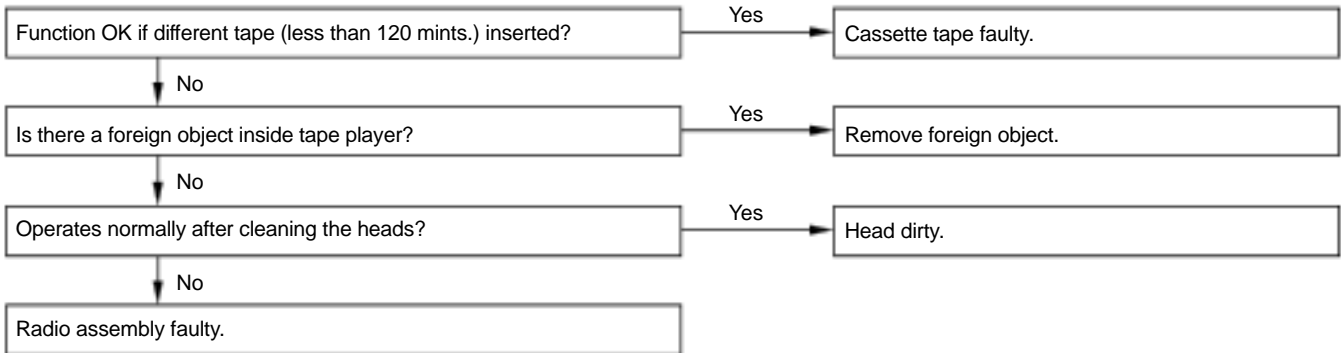

15	Tape Player	CASSETTE TAPE WILL NOT BE EJECTED
-----------	--------------------	--

• Radio-Tape Player Unit (Built-in Power Amplifier)

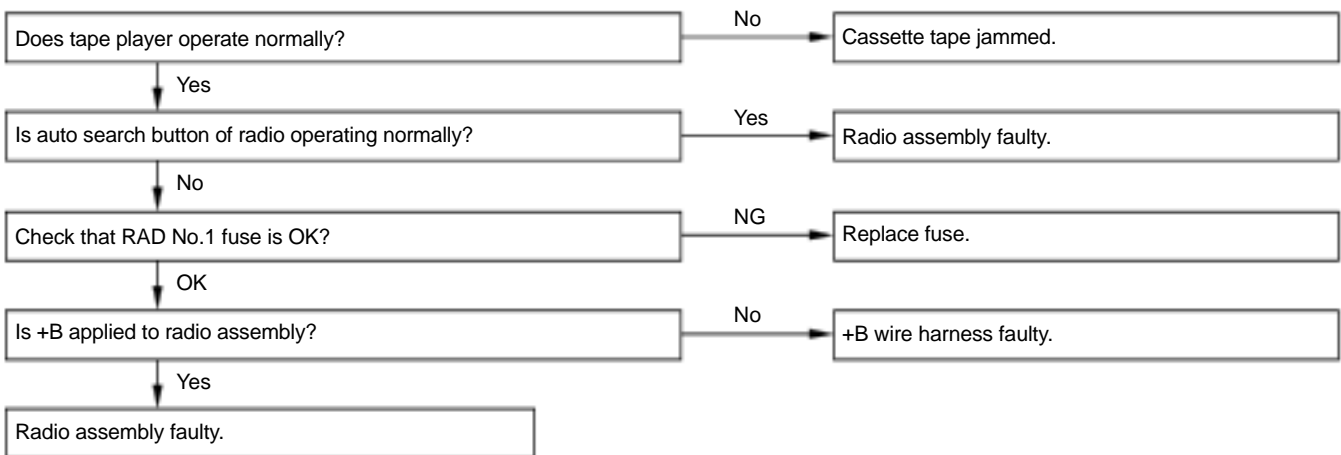

• Radio-Tape Player Unit (Separate Power Amplifier)
 • Radio-Tape Player-CD Player Unit (Separate Power Amplifier)

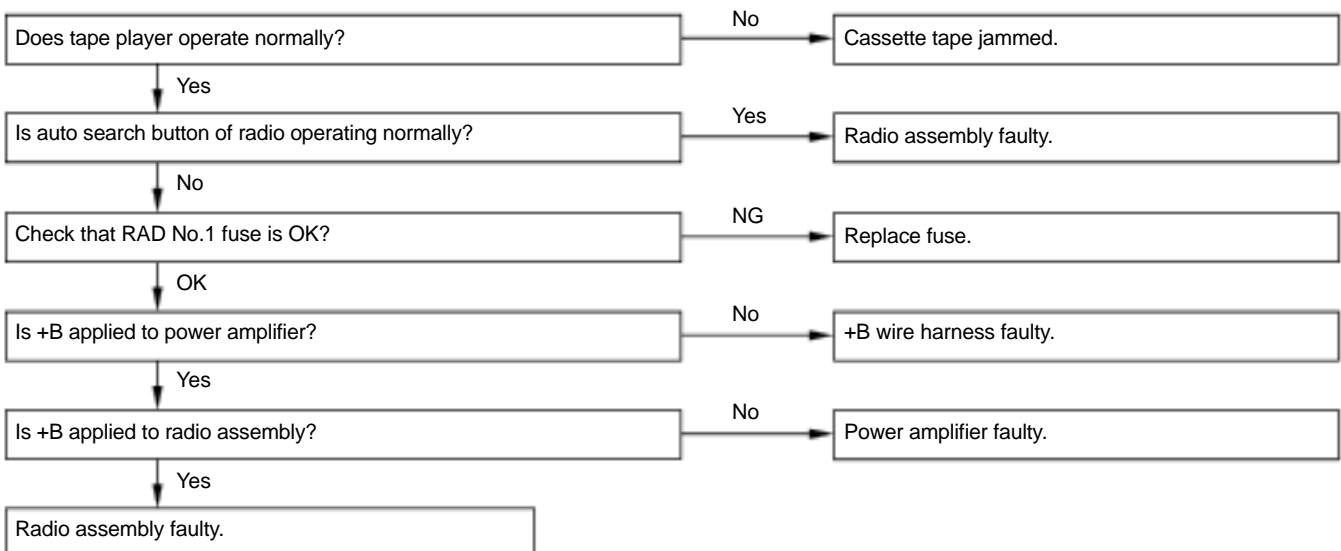

16	CD Player	CD CANNOT BE INSERTED
-----------	------------------	------------------------------

- Radio-CD Player Unit (Built-in Power Amplifier)
- Radio-CD Player Unit (Separate Power Amplifier)
- Radio-Tape Player - CD Player (Separate Power Amplifier)

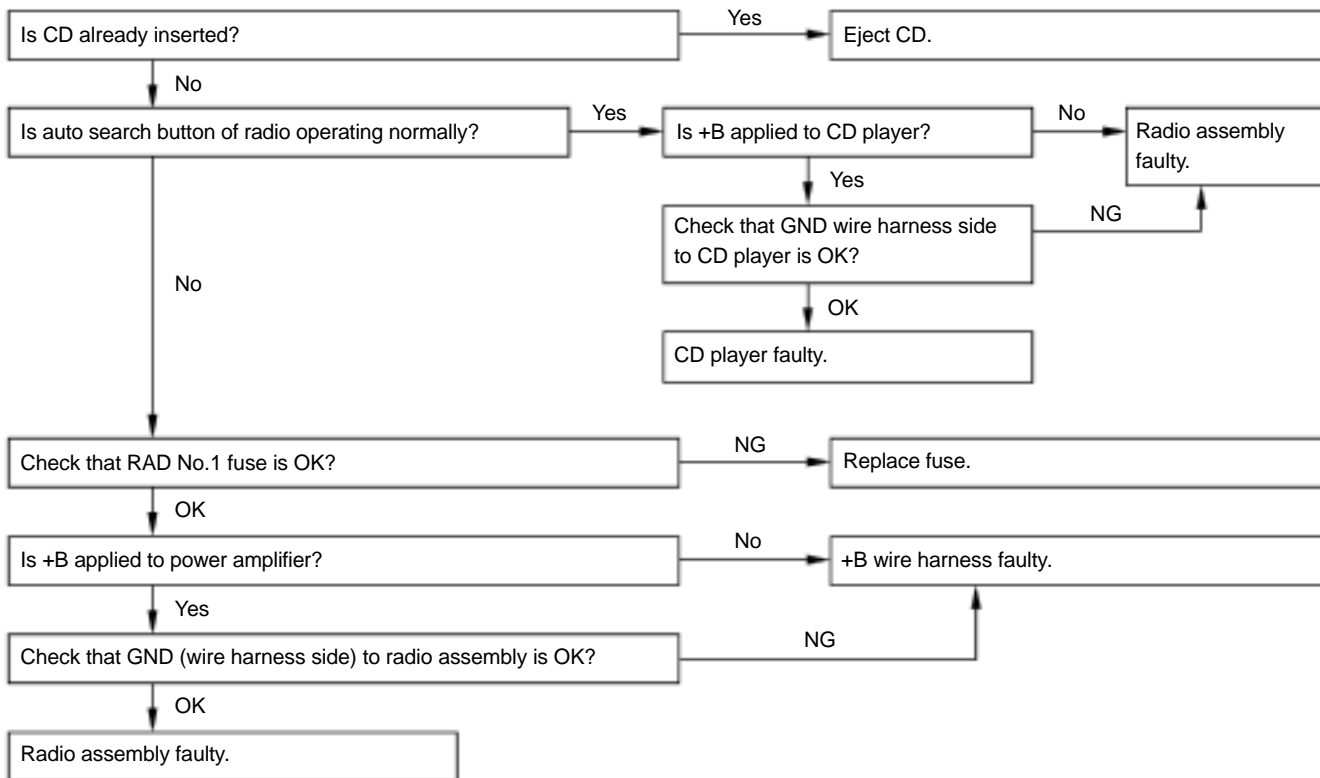

17	CD Player	CD INSERTED, BUT NO POWER
-----------	------------------	----------------------------------

- Radio-CD Player Unit (Built-in Power Amplifier)
- Radio-CD Player Unit (Separate Power Amplifier)
- Radio-Tape Player - CD Player (Separate Power Amplifier)

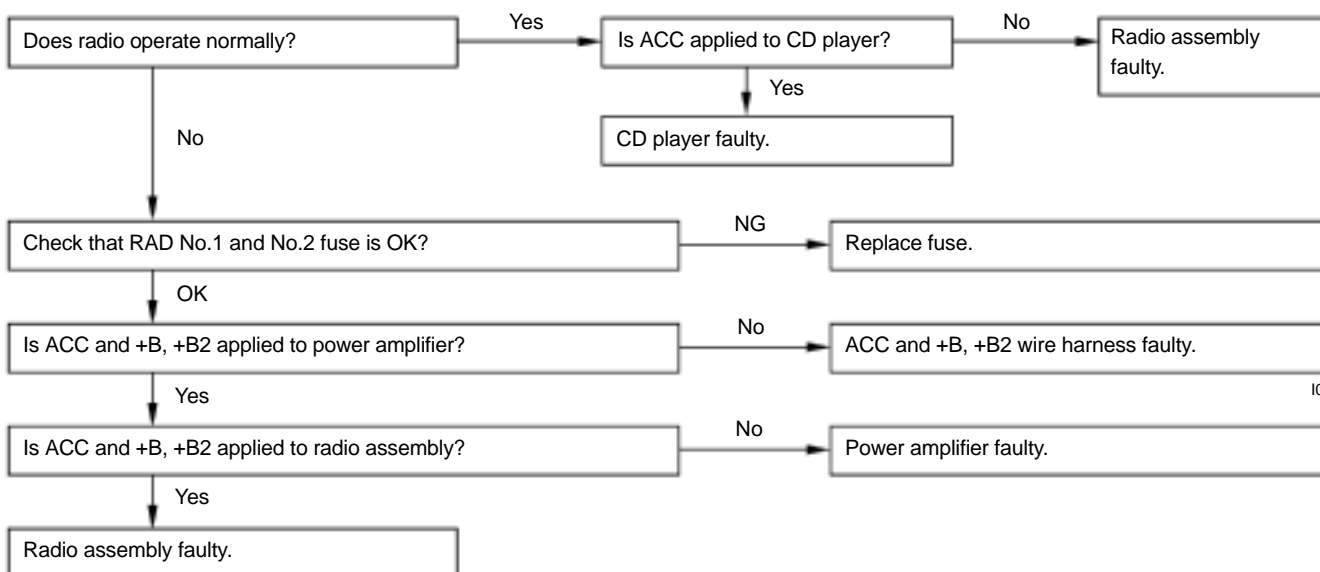

103355

103355

18	CD Player	POWER COMING IN, BUT CD PLAYER NOT OPERATING
-----------	------------------	---

- Radio-CD Player Unit (Built-in Power Amplifier)
- Radio-CD Player Unit (Separate Power Amplifier)
- Radio-Tape Player - CD Player (Separate Power Amplifier)

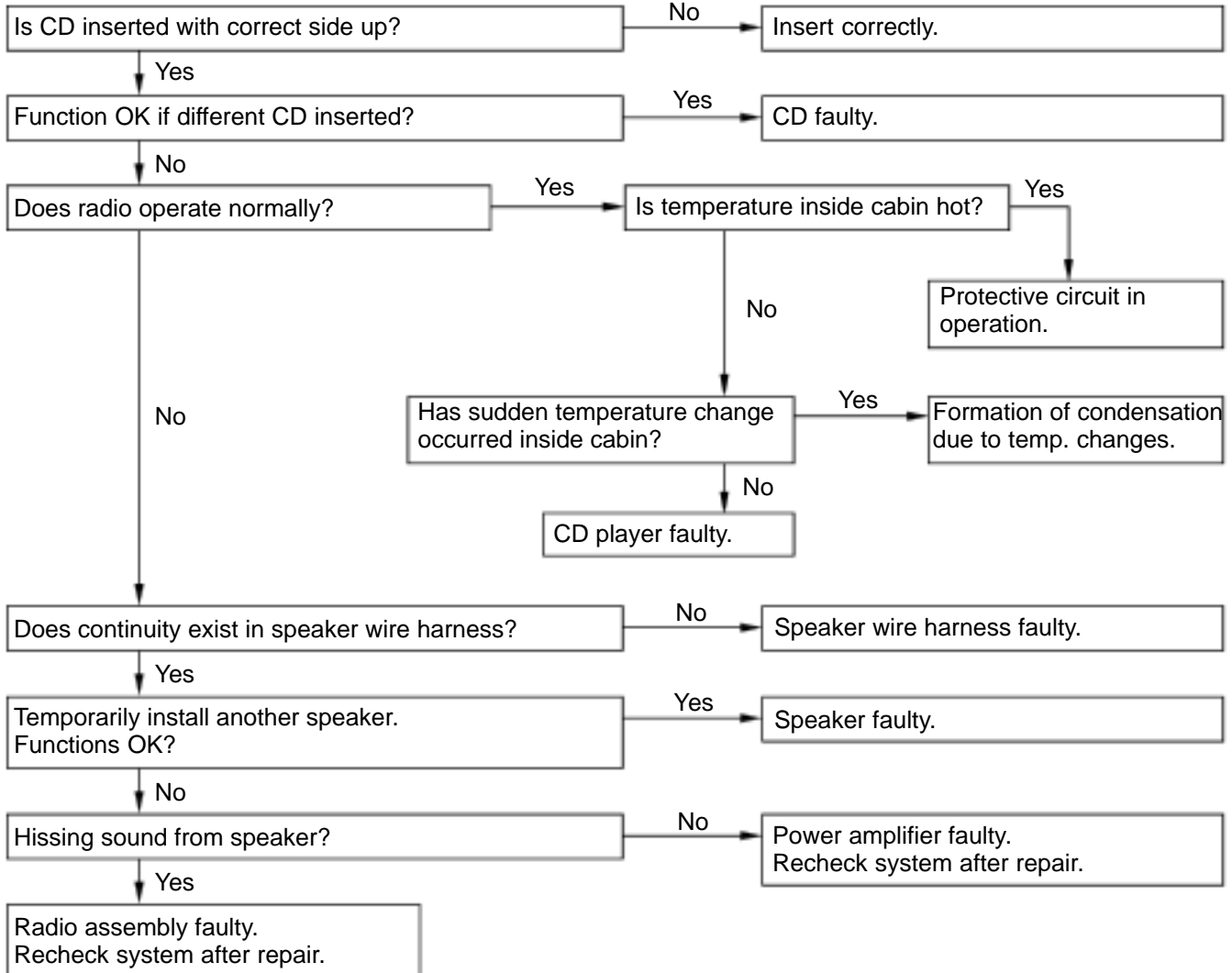

19	CD Player	SOUND JUMPS
-----------	------------------	--------------------

- Radio-CD Player Unit (Built-in Power Amplifier)
- Radio-CD Player Unit (Separate Power Amplifier)
- Radio-Tape Player - CD Player (Separate Power Amplifier)

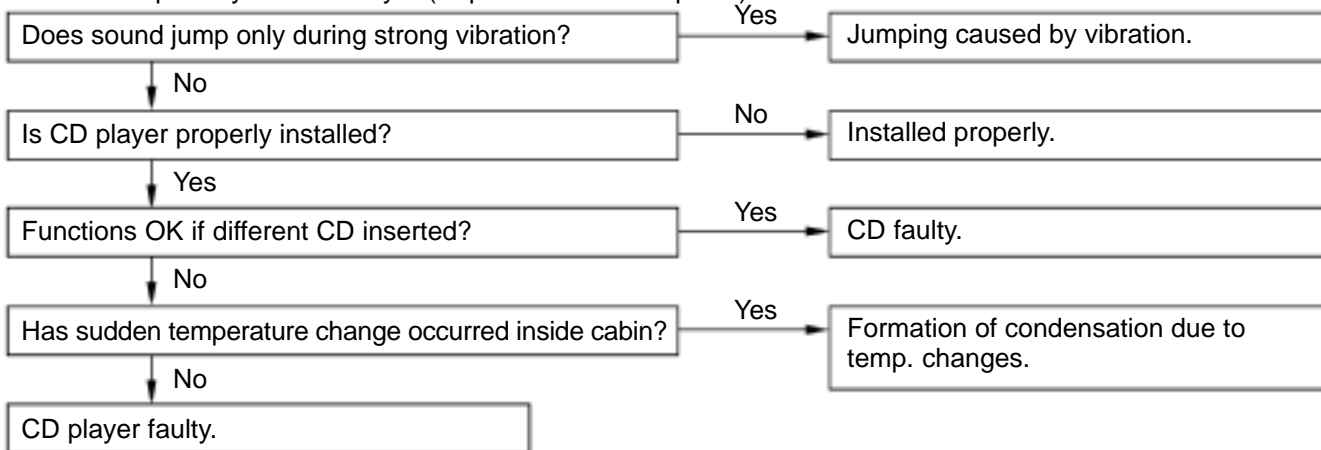

20	CD Player	SOUND QUALITY POOR (VOLUME FAINT)
-----------	------------------	--

- Radio-CD Player Unit (Built-in Power Amplifier)
- Radio-CD Player Unit (Separate Power Amplifier)
- Radio-Tape Player - CD Player (Separate Power Amplifier)

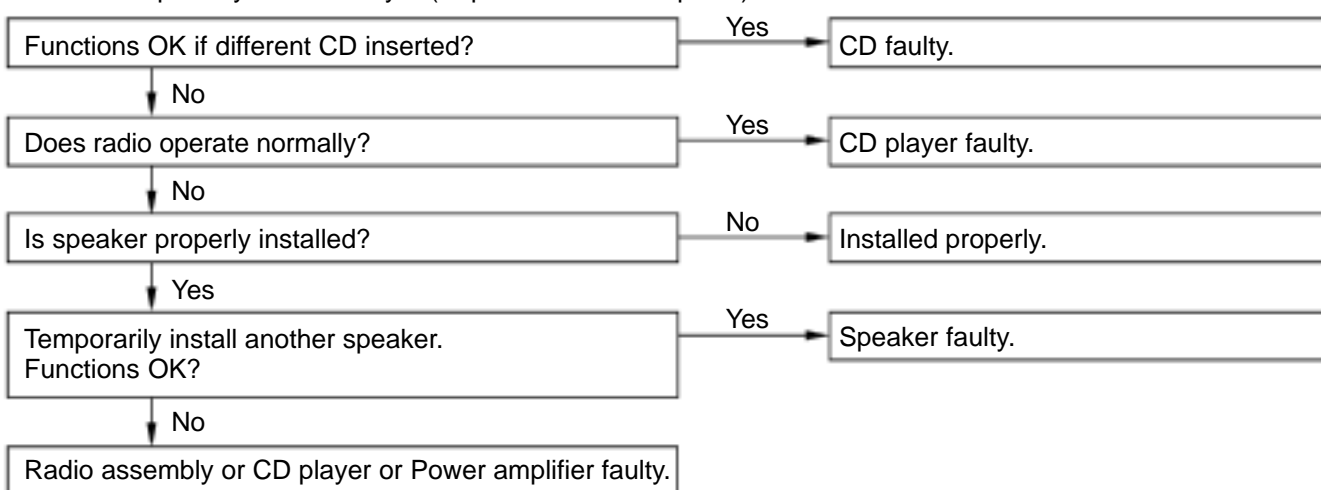

I03357

21	CD Player	EITHER SPEAKER DOES NOT WORK
-----------	------------------	-------------------------------------

- Radio-CD Player Unit (Built-in Power Amplifier)
- Radio-CD Player Unit (Separate Power Amplifier)
- Radio-Tape Player - CD Player (Separate Power Amplifier)

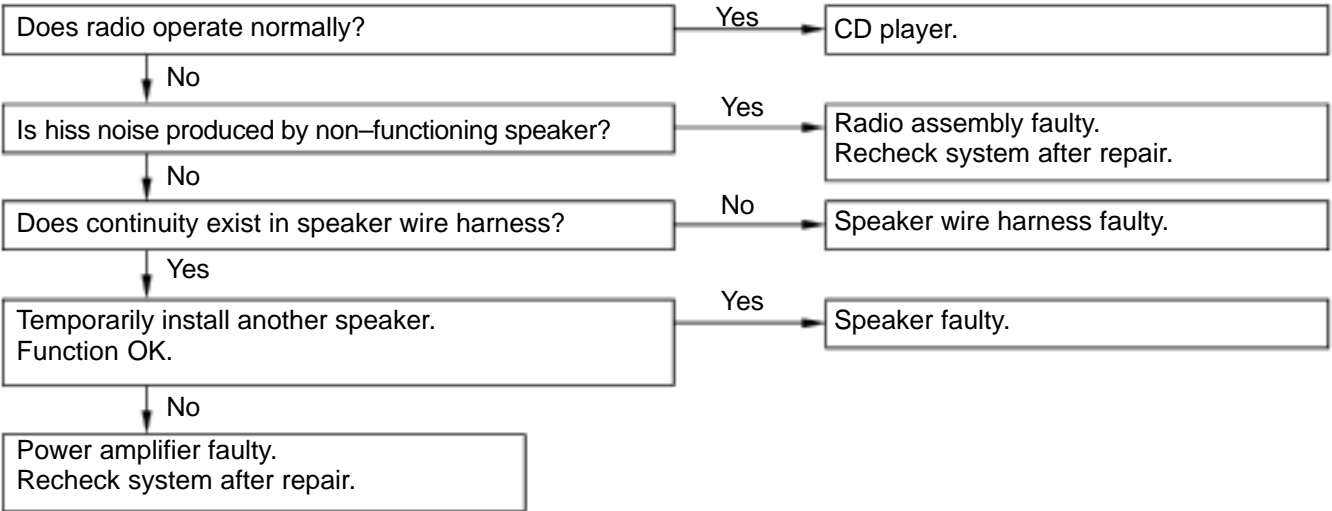

22	CD Player	CD WILL NOT BE EJECTED
-----------	------------------	-------------------------------

- Radio-CD Player Unit (Built-in Power Amplifier)
- Radio-CD Player Unit (Separate Power Amplifier)
- Radio-Tape Player - CD Player (Separate Power Amplifier)

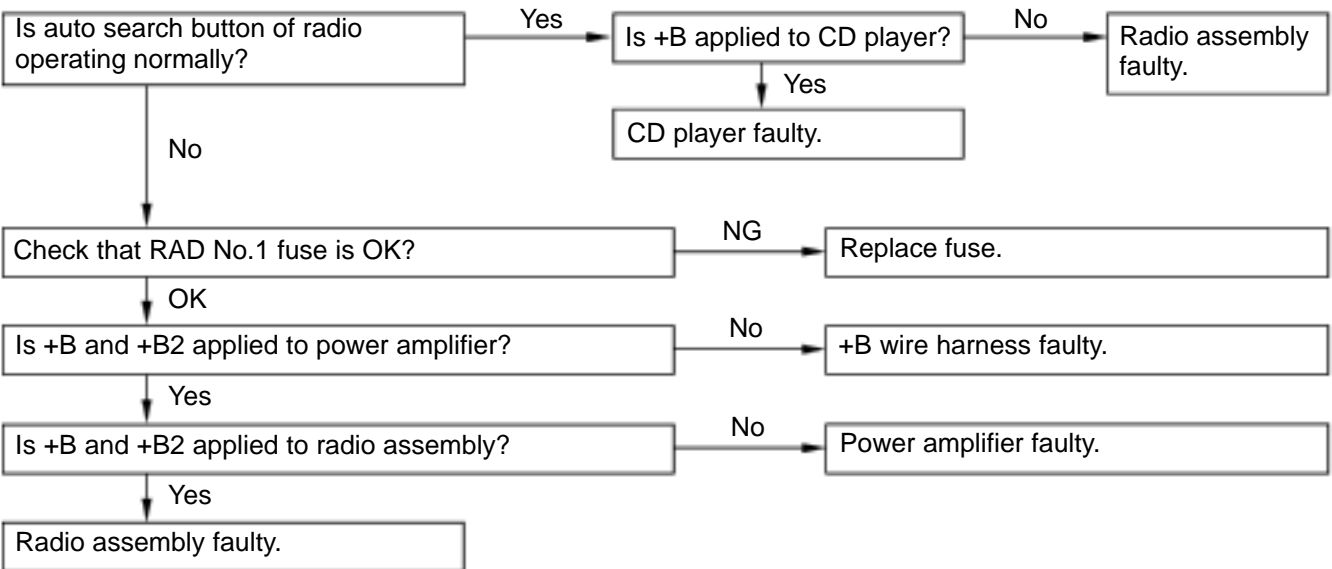

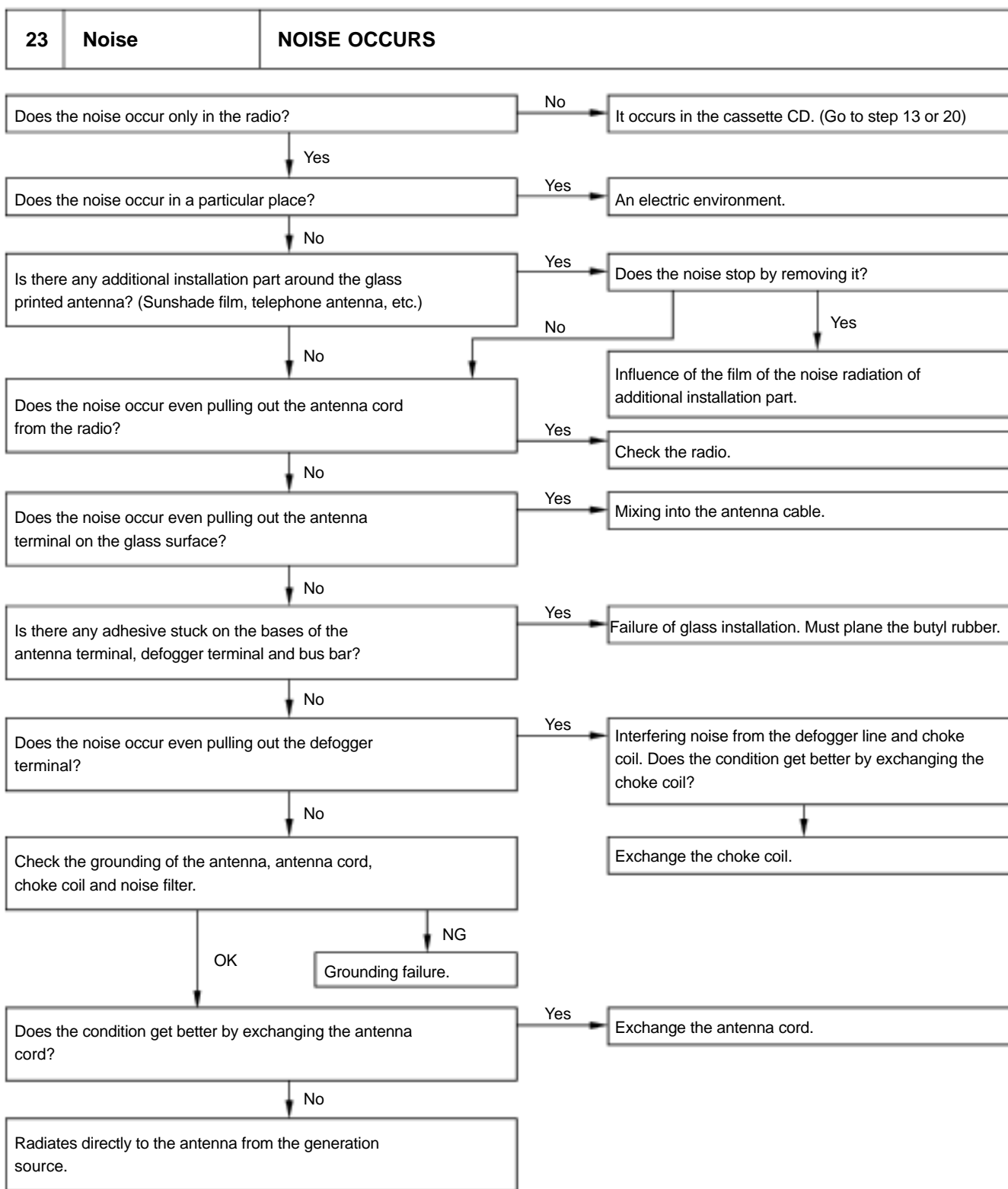

101473

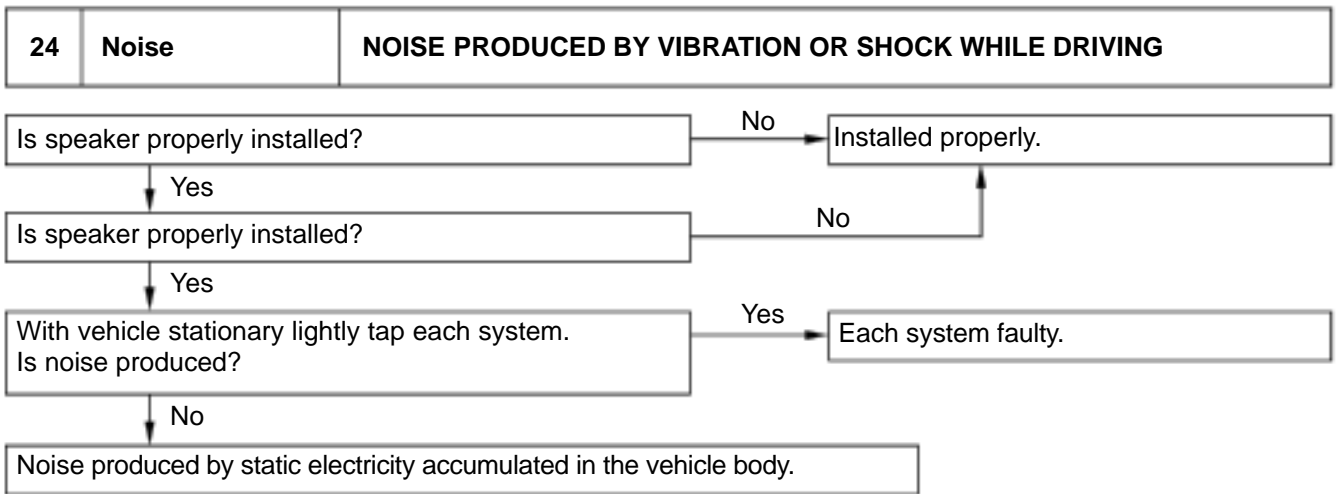

I01474

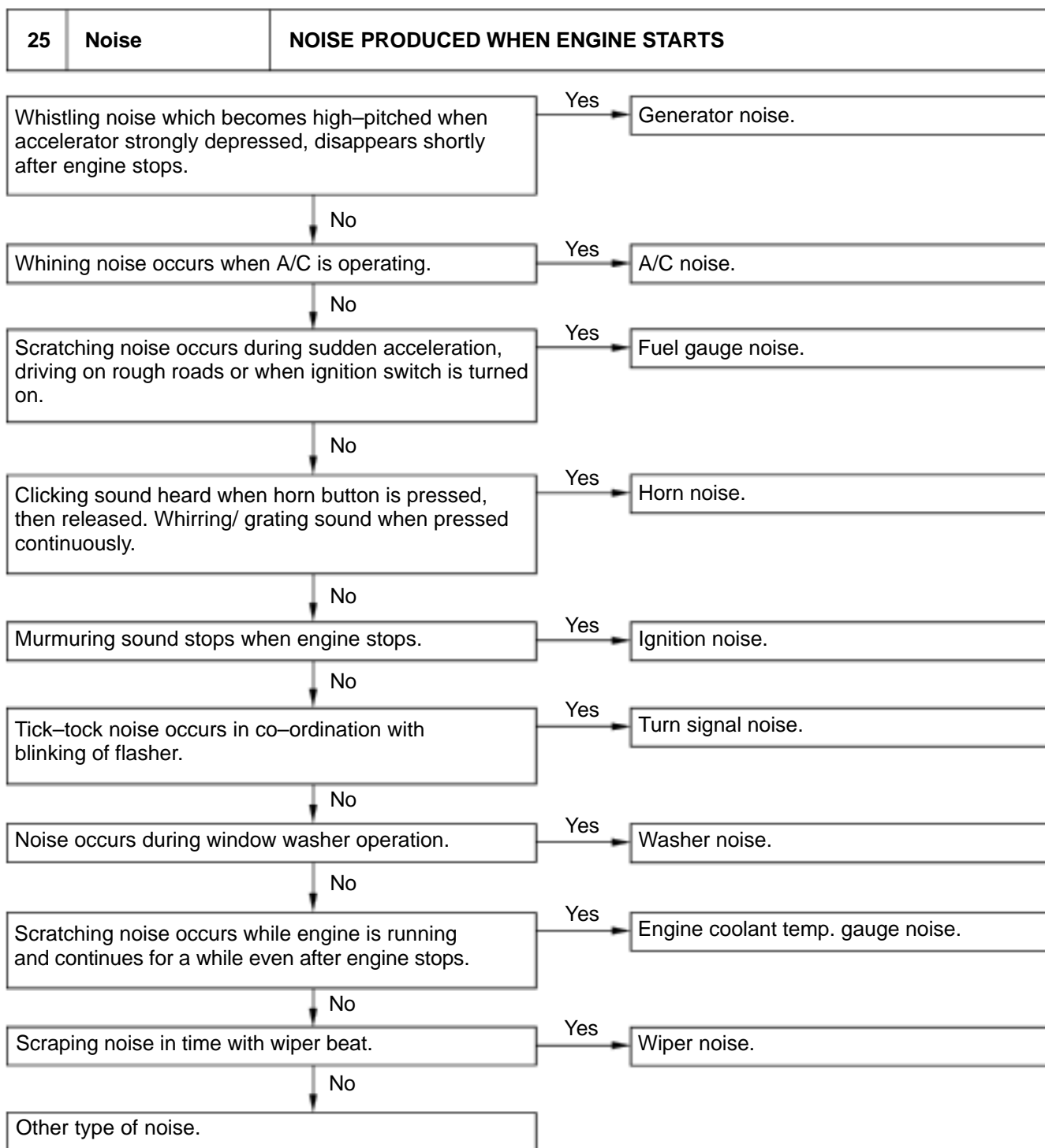

I01475

LOCATION

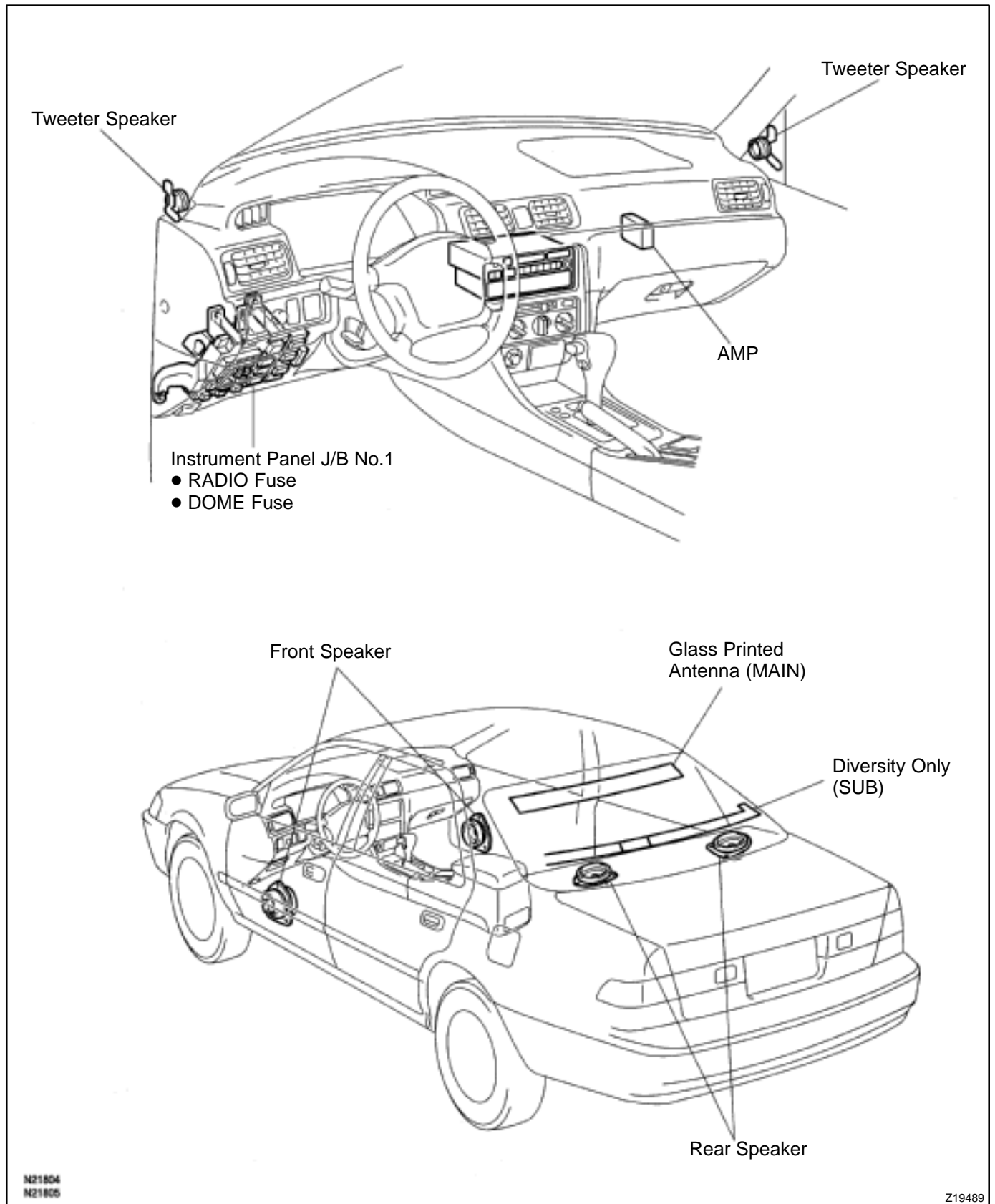

N21804
N21805

Z19489

INSPECTION

1. GLASS PRINTED ANTENNA INSPECTION PROCEDURE

NOTICE:

- When cleaning the glass, use soft dry cloth, and wipe the glass in the direction of the wire. Take care not to damage the wires.
- Do not use detergents or glass cleaners with abrasive ingredients.

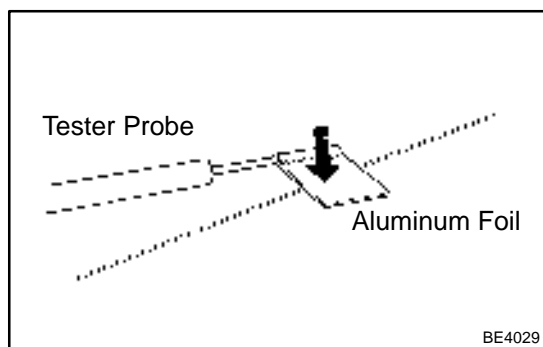

NOTICE:

In order not to damage the glass printed antenna, wrap up the tip of the tester stick with aluminum foil as shown in the illustration and check by holding the aluminum foil with a finger.

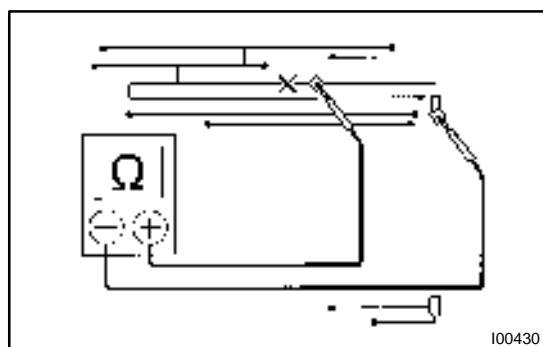

By placing and moving the tester stick along the glass printed antenna, check if continuity exists.

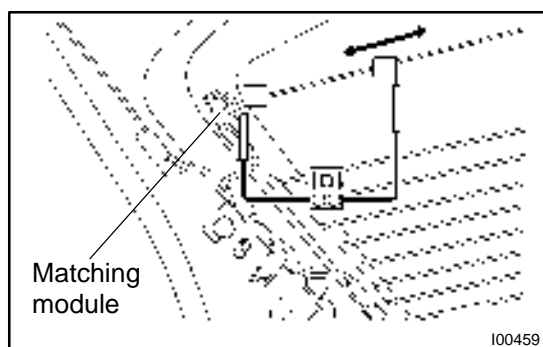

HINT:

Matching module is built in the bus bar of the glass printed antenna (main terminal side) of CAMRY and no continuity exists between the terminal and the antenna. Therefore, for the continuity checking of the glass printed antenna on the main antenna side of CAMRY, place one probe of the tester on the position beside the bus bar (position shown in the illustration) and check by making the other probe of the tester move along.

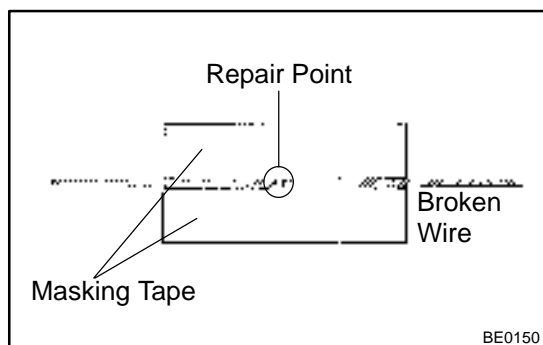

2. GLASS PRINTED ANTENNA REPAIR PROCEDURE

- (a) Clean the broken wire tips with grease, wax and silicone remover.
- (b) Place the masking tape along both sides of the wire for repair.
- (c) Thoroughly mix the repair agent (Dupont paste No. 4817).

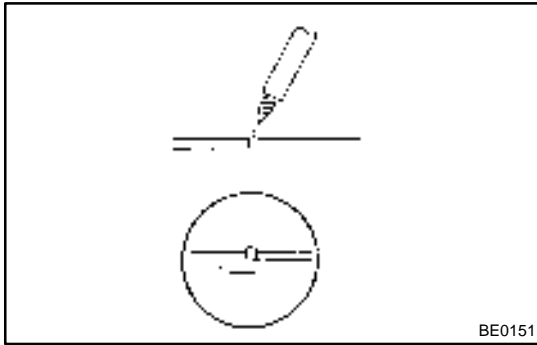

- (d) Using a fine tip brush, apply a small amount of the agent to the wire.
- (e) After a few minutes, remove the masking tape.

CLOCK TROUBLESHOOTING

BE0B1-02

HINT:

Troubleshoot the clock according to the table below.

Clock will not operate	1
Clock loses or gains time	2

± 1.5 seconds / day

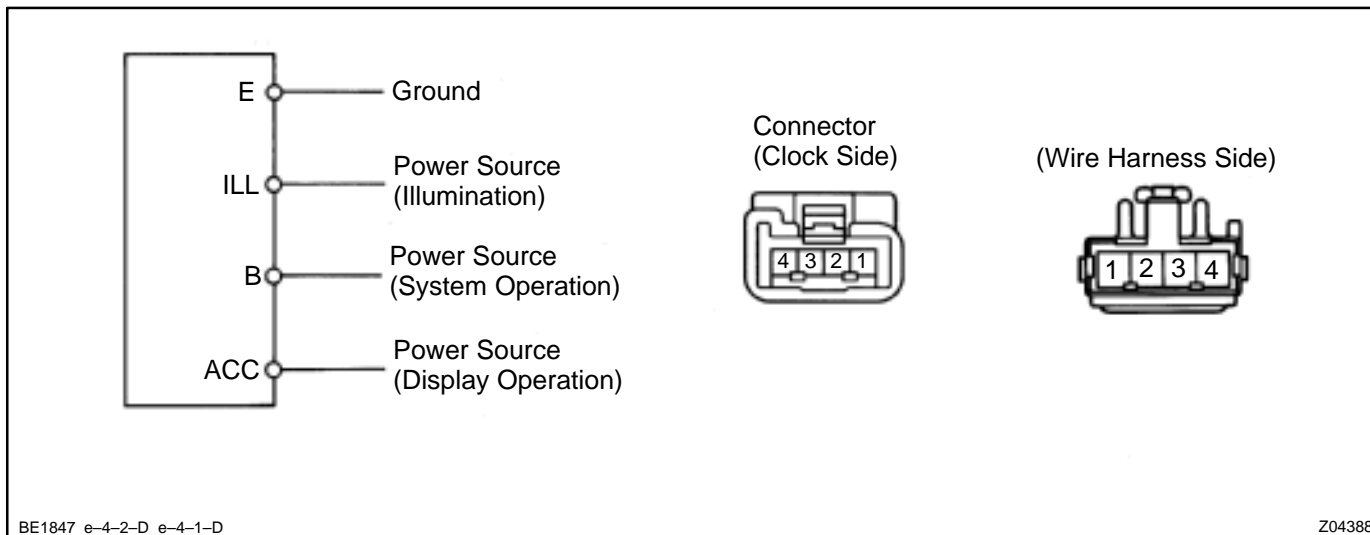

1 CLOCK WILL NOT OPERATE

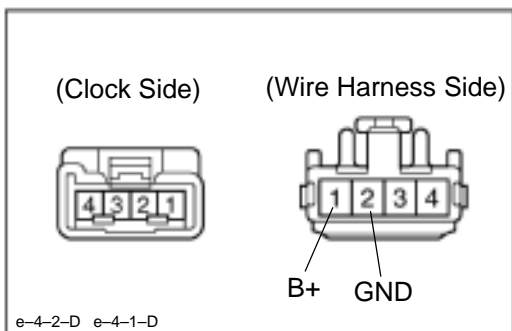

- (a) Check that the battery positive voltage is 10 – 16 V.
If voltage is not as specified, replace the battery.
- (b) Check that the DOME fuse is not blown.
If the fuse is blown, replace the fuse and check for short circuit.
- (c) Troubleshoot the clock as follows.
HINT: Inspect the connector on the wire harness side.

```

    graph TD
      Q1[Is there battery positive voltage between terminal B+ and body ground?] -- No --> A1[Open or short circuit in wire harness between terminal GND and body ground.]
      Q1 -- Yes --> Q2[Does continuity exist between terminal GND and body ground.]
      Q2 -- No --> A2[Open circuit in wire harness between terminal GND and body ground.]
      Q2 -- Yes --> R1[Replace clock.]
    
```

V04421

2

CLOCK LOSES OR GAINS TIME

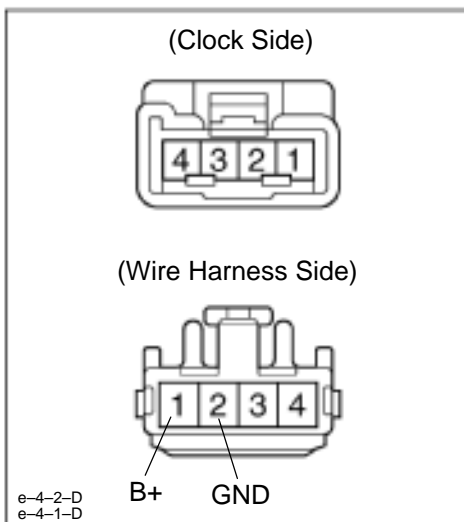

- (a) Check that the battery positive voltage is 10 – 16 V.
If voltage is not as specified, replace the battery.
- (b) Inspect the error of the clock.
Allowable error (per day): ± 1.5 seconds
If the error exceeds the allowable error, replace the clock.
- (c) Check that the clock adjusting button is caught in position, and does not return.
If the button is not returned, repair or replace the clock.
- (d) Troubleshoot the clock as follows.
HINT: Inspect the connector on the wire harness side.

Is there 10 – 16 V between terminal B+ and body ground?

Below 10 V

Locate cause and repair, or recharge battery.

Yes

Adjust or replace clock.

V04422

ENGINE IMMOBILISER SYSTEM

REGISTRATION PROCEDURE

BE0B2-06

1. KEY REGISTRATION IN AUTOMATIC REGISTRATION MODE

(a) Registration of a new transponder key.

HINT:

- This must be done when you have installed a new ECM.
- The new ECM is in the automatic key code registration mode. The already fixed number of key codes for this ECM can be registered.
On this type of vehicle, up to 4 key codes can be registered.
- In the automatic registration mode, the last key registered becomes sub-key.

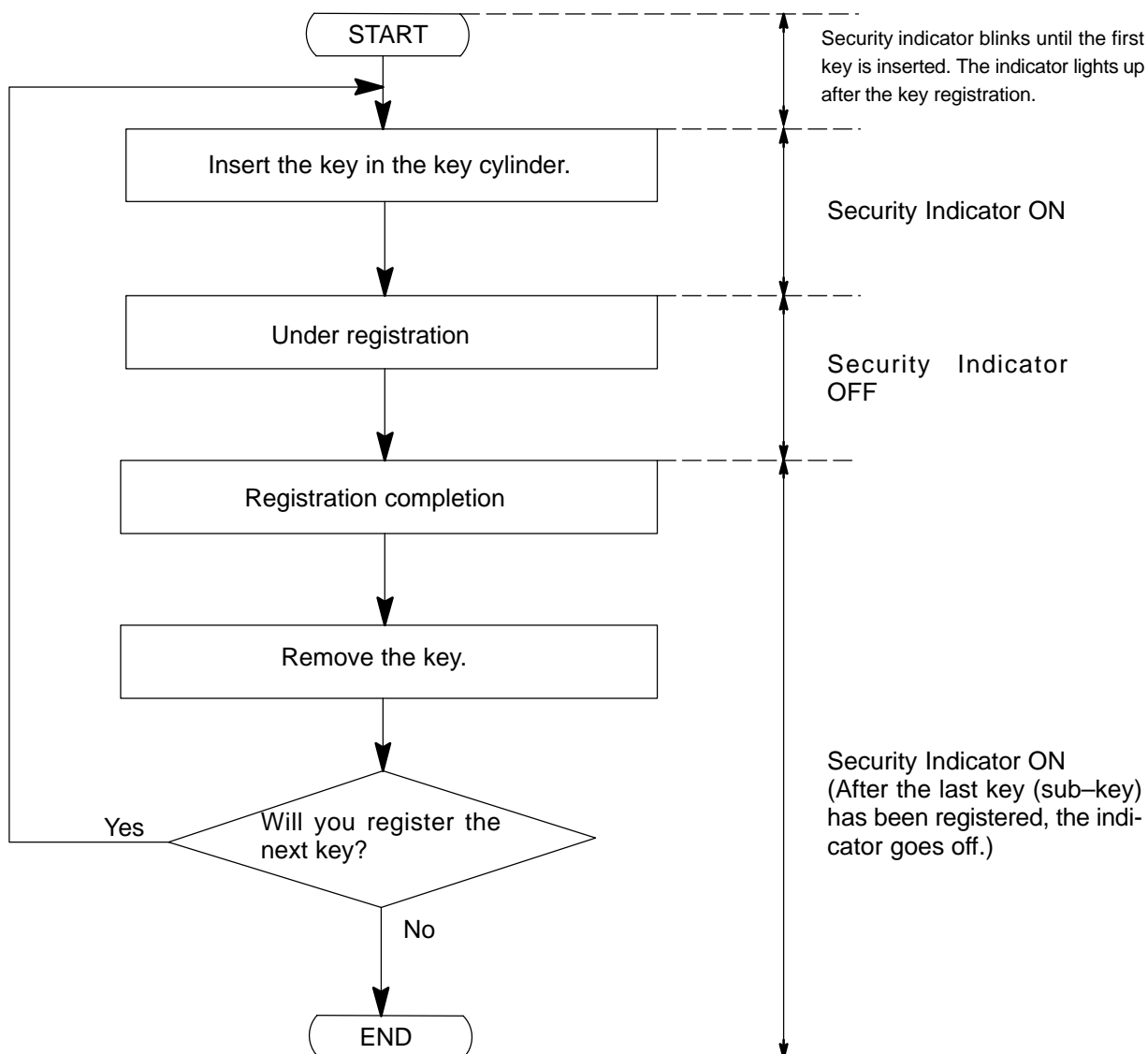

HINT:

- When a key is not inserted in the key cylinder in the automatic registration mode, the security indicator always lights on.
- When the immobiliser system operations normally and the key is pull out, the security indicator blinks.
- When key code registration could not be performed in the automatic registration mode, code 2-1 is output from the security indicator and when inserting the already registered key, code 2-2 is output.

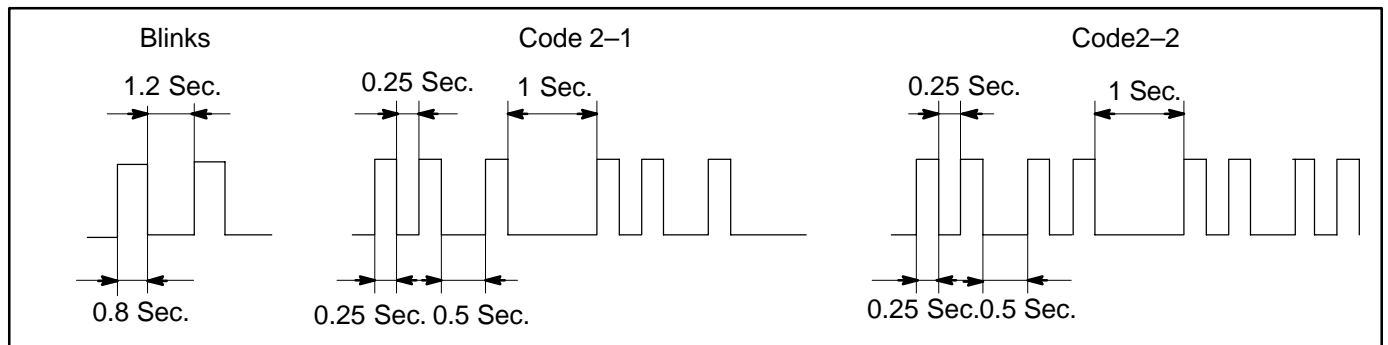

(b) Automatic registration mode completion

If completing the mode forcibly when more than 1 key code have been registered in the automatic registration mode, perform the following procedures.

After 1 more key code have been registered with master key, perform step (1) or (2) without pulling the key out or inserting the already registered key.

(1) Depress and release brake pedal 5 times or more within 15sec.

(2) With the TOYOTA hand-held tester, require automatic registration mode completion.

2. REGISTRATION OF ADDITIONAL MASTER KEY

There are 2 ways for registration of additional master key, one is depressing brake pedal and acceleration pedal and the other is using TOYOTA hand-held tester.

HINT:

- It is possible to register up to 7 master key codes including the already registered key code.
- When any operation time described below is over, registration mode completes.
- When the next procedure is performed while the timer is working, the timer completes counting time, then next timer starts.

(1) Depressing brake pedal and acceleration pedal:

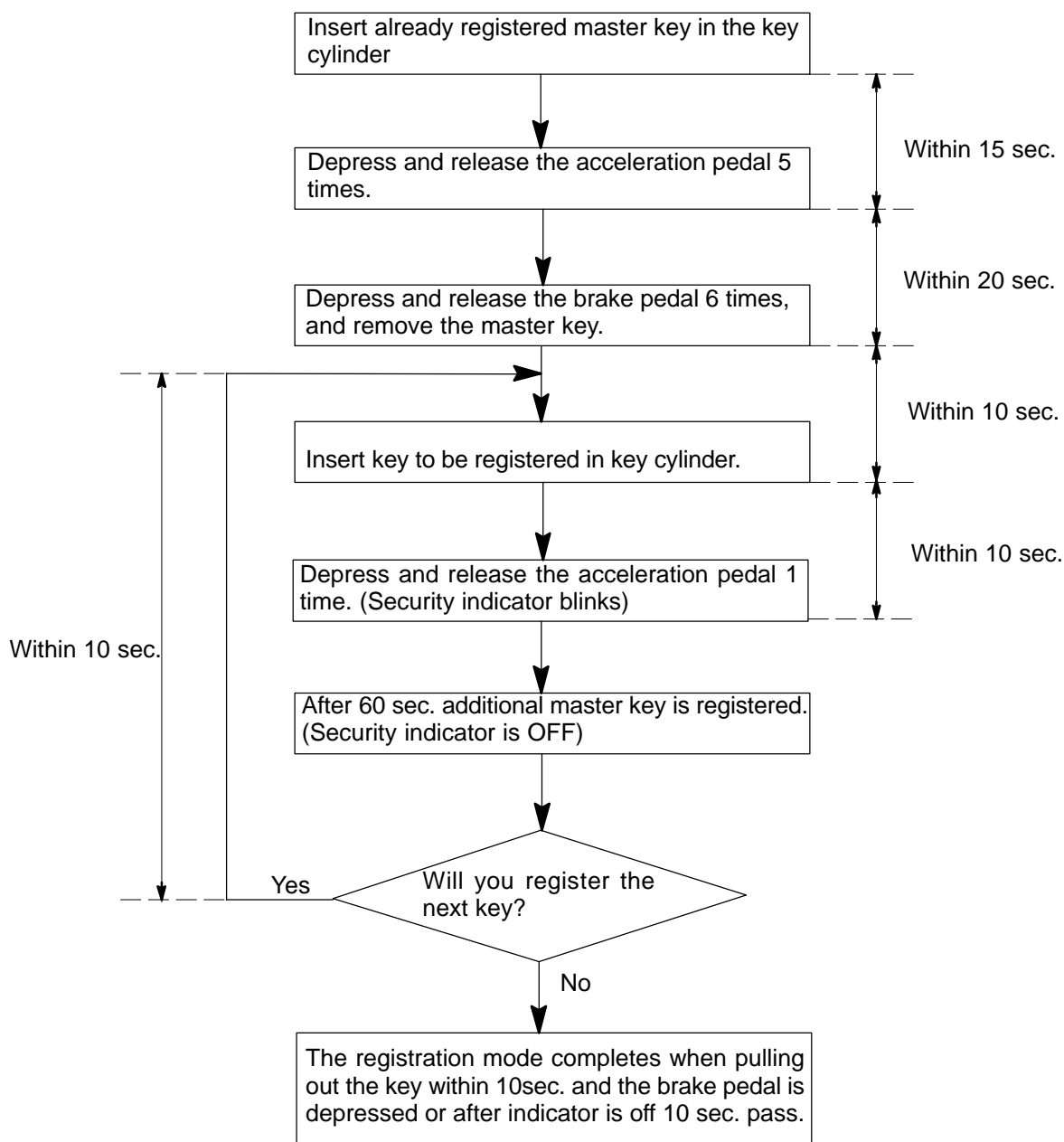

(2) Using TOYOTA hand-held tester:

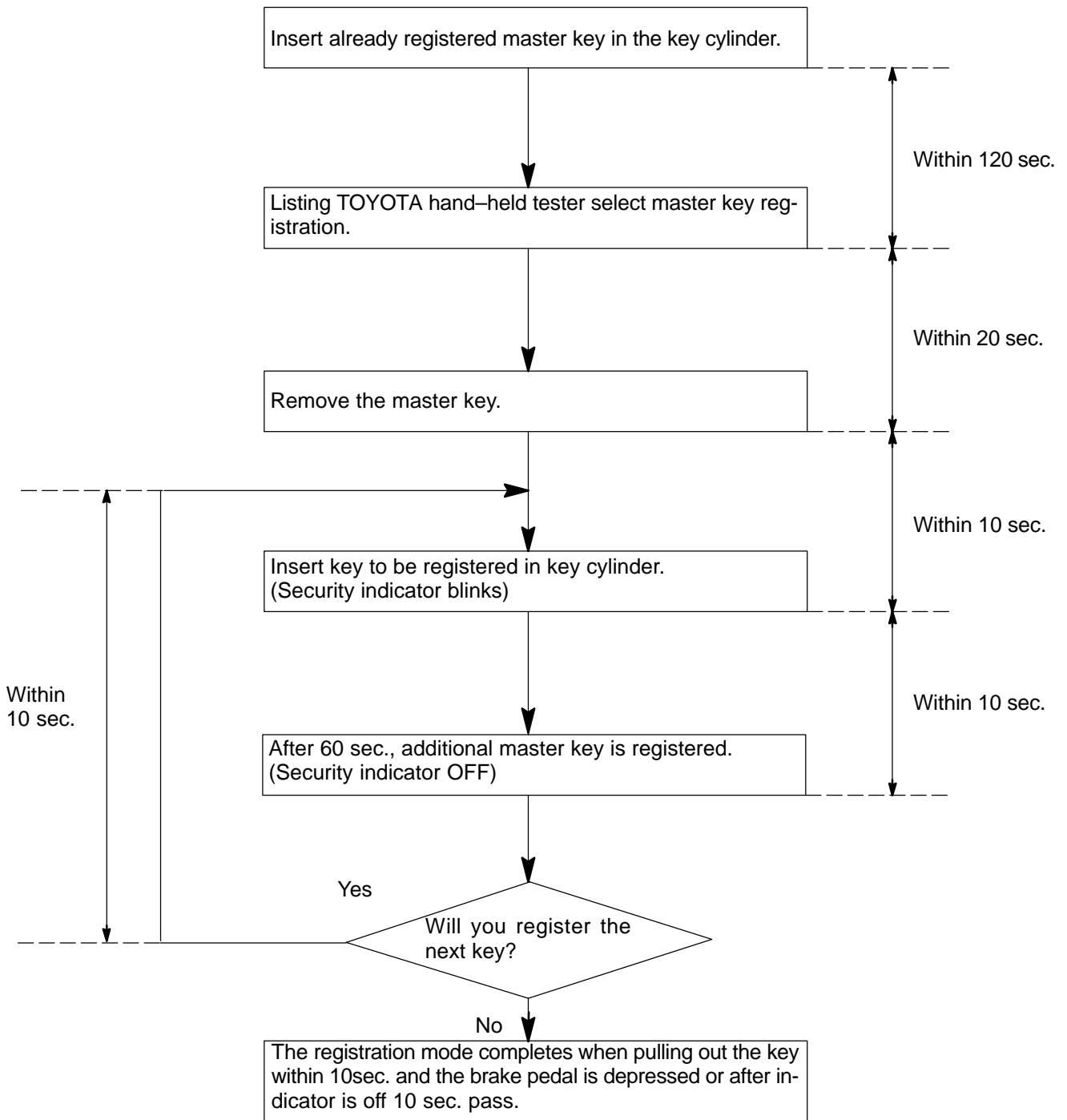

3. REGISTRATION ADDITIONAL OF SUB-KEY

There are 2 ways for registration of additional sub-key, one is depressing brake pedal and acceleration pedal and the other is using TOYOTA hand-held tester.

HINT:

- It is possible to register up to 3 sub-key codes including the already registered key code.
- When any operation time described below is over, registration mode completes.
- When the next procedure is performed while the timer is working, the timer completes counting time, then next timer starts.

(1) Depressing brake pedal and acceleration pedal:

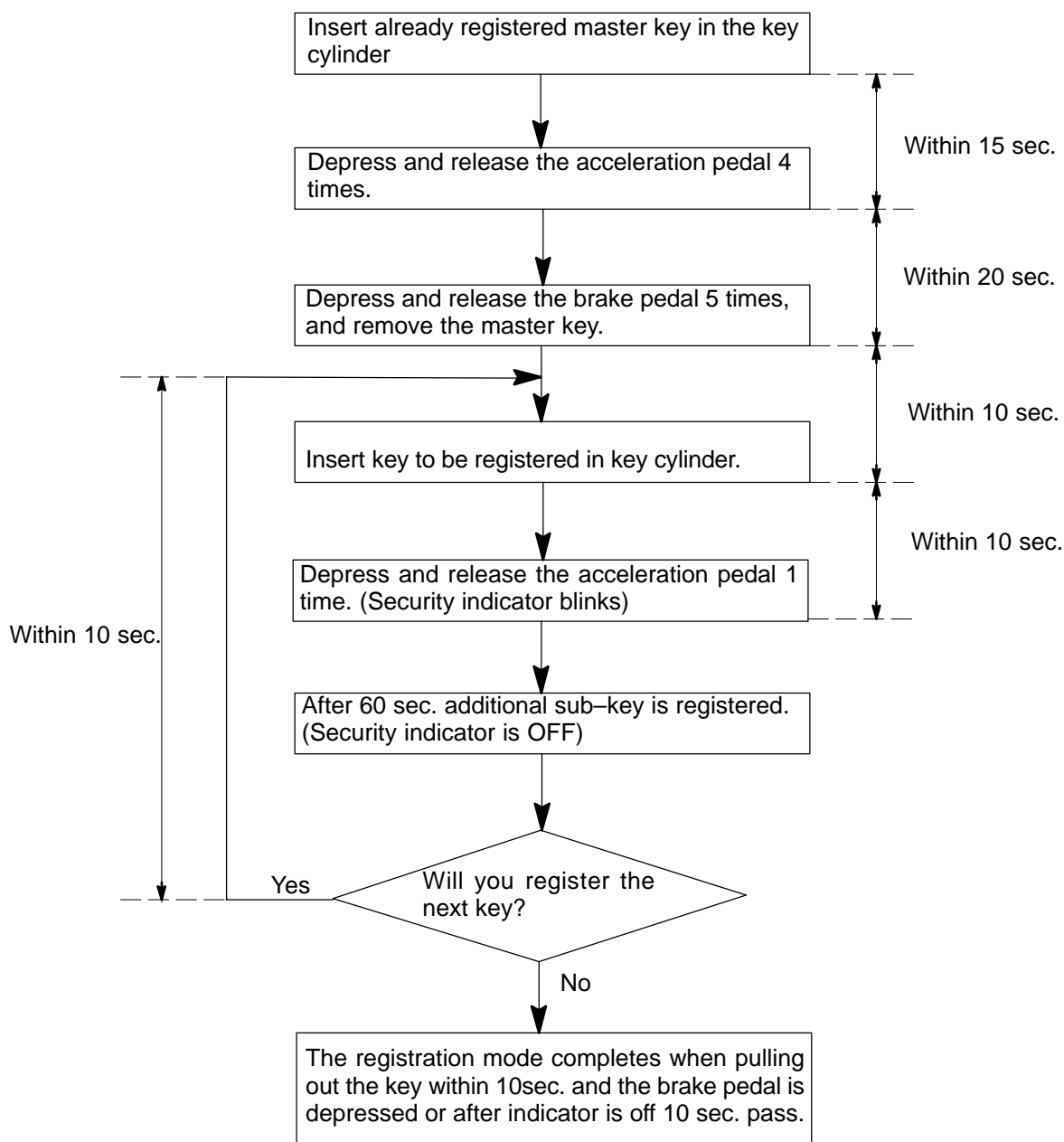

(2) Using TOYOTA hand-held tester:

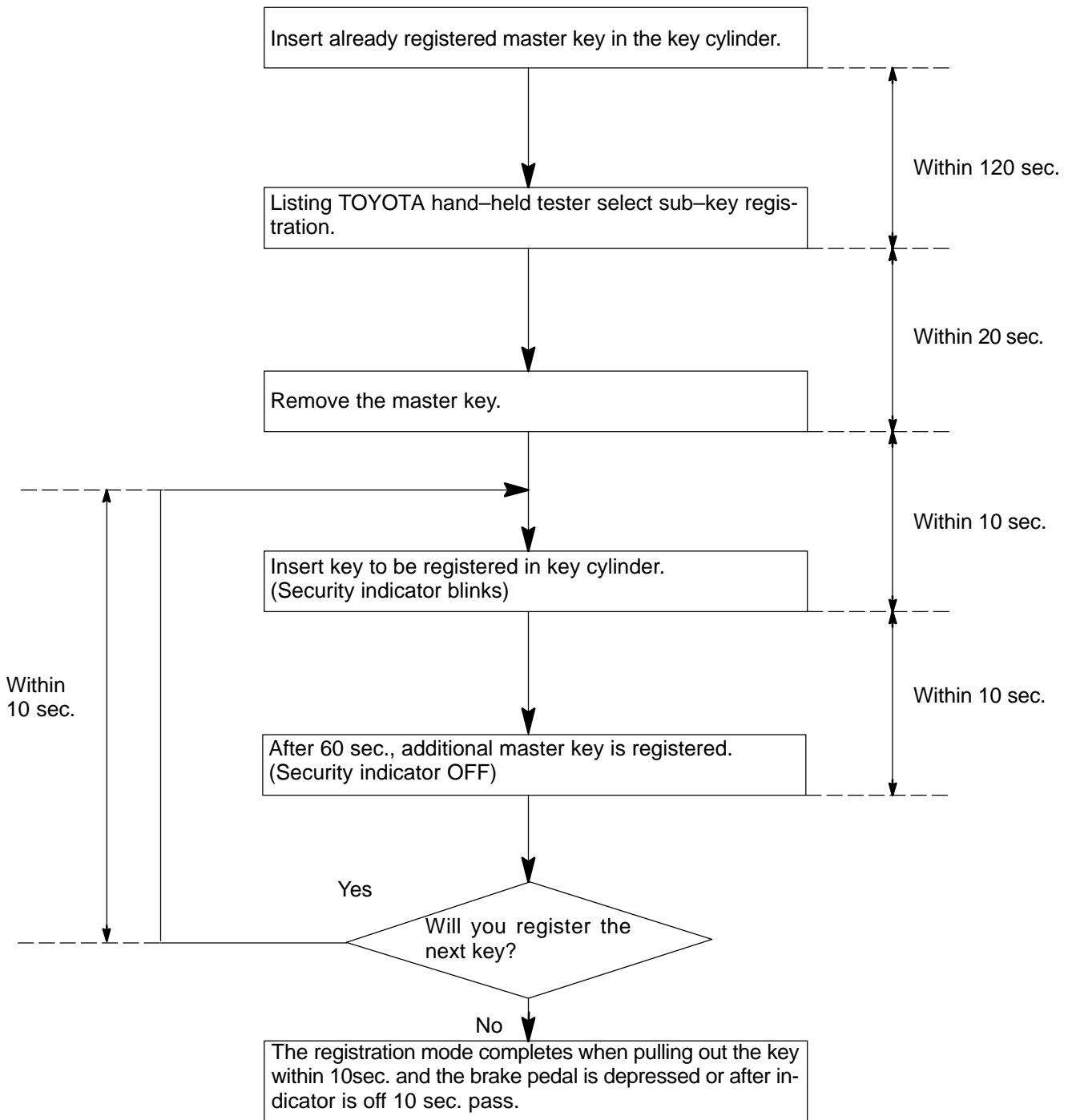

4. ERASURE OF TRANSPONDER KEY CODE

There are 2 ways for erasure of transponder key code, one is depressing brake pedal and acceleration pedal and the other is using TOYOTA hand-held tester.

NOTICE:

All other master and sub-key codes are deleted leaving the master key code to use the operation. When using the key which was used before deleting, it is necessary to register the code again.

HINT:

- When any operation time described below is over, registration mode completes.
- When the next procedure is performed while the timer is working, the timer completes counting time, then next timer starts.

(1) Depressing brake pedal and acceleration pedal:

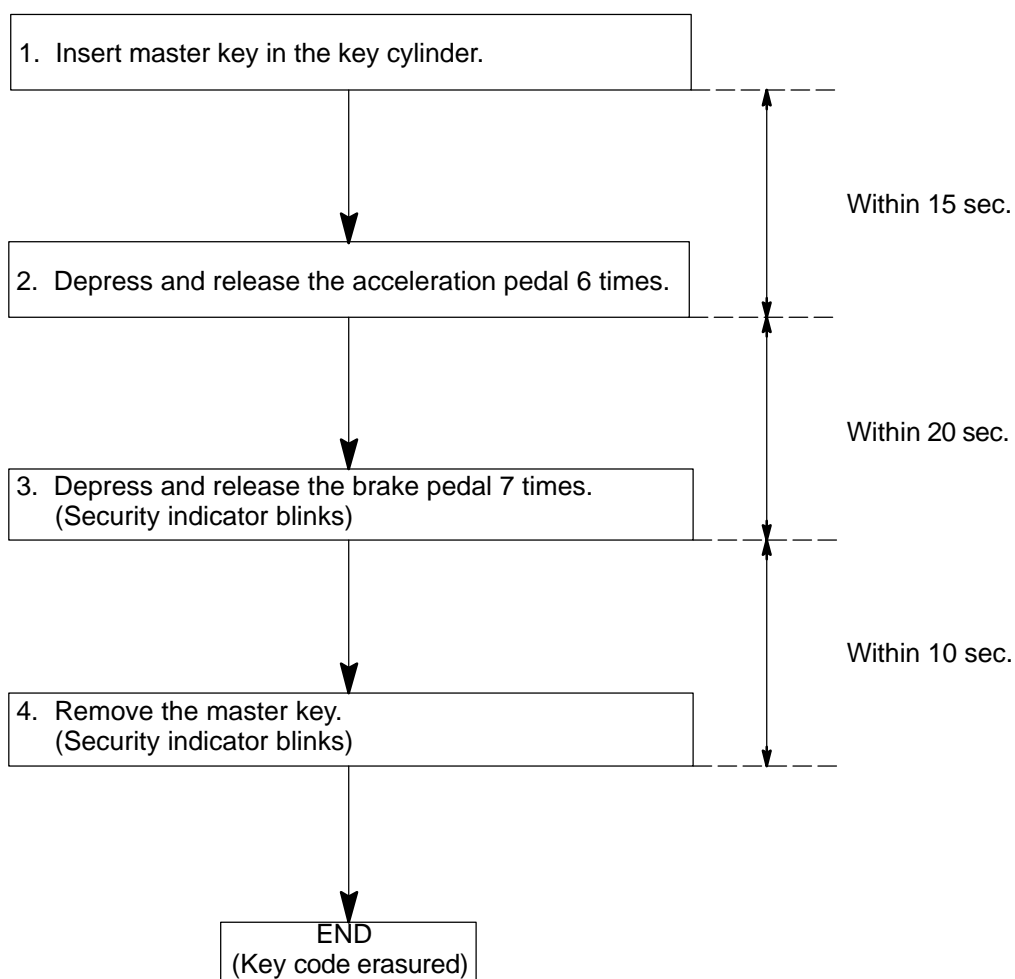

HINT:

When the key cannot be pulled out in the step 4, key code deletion is canceled. (Security indicator is OFF)

(2) Using TOYOTA hand-held tester:

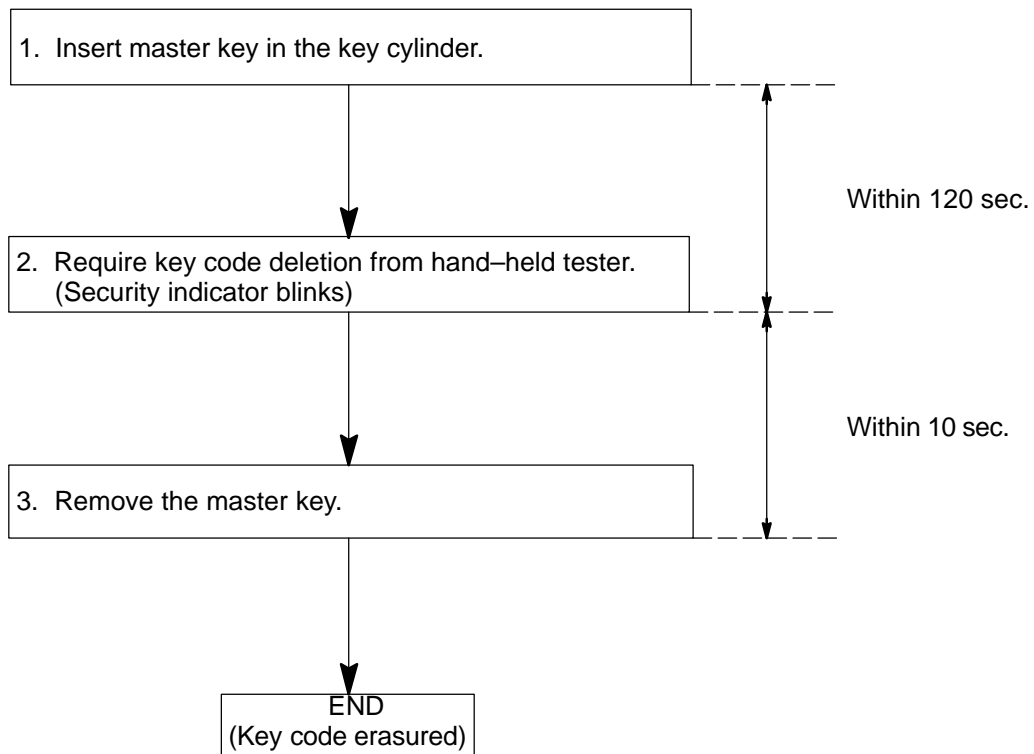

HINT:

When the key cannot be pulled out in the step 3, key code deletion is canceled.
(Security indicator is OFF)

LOCATION

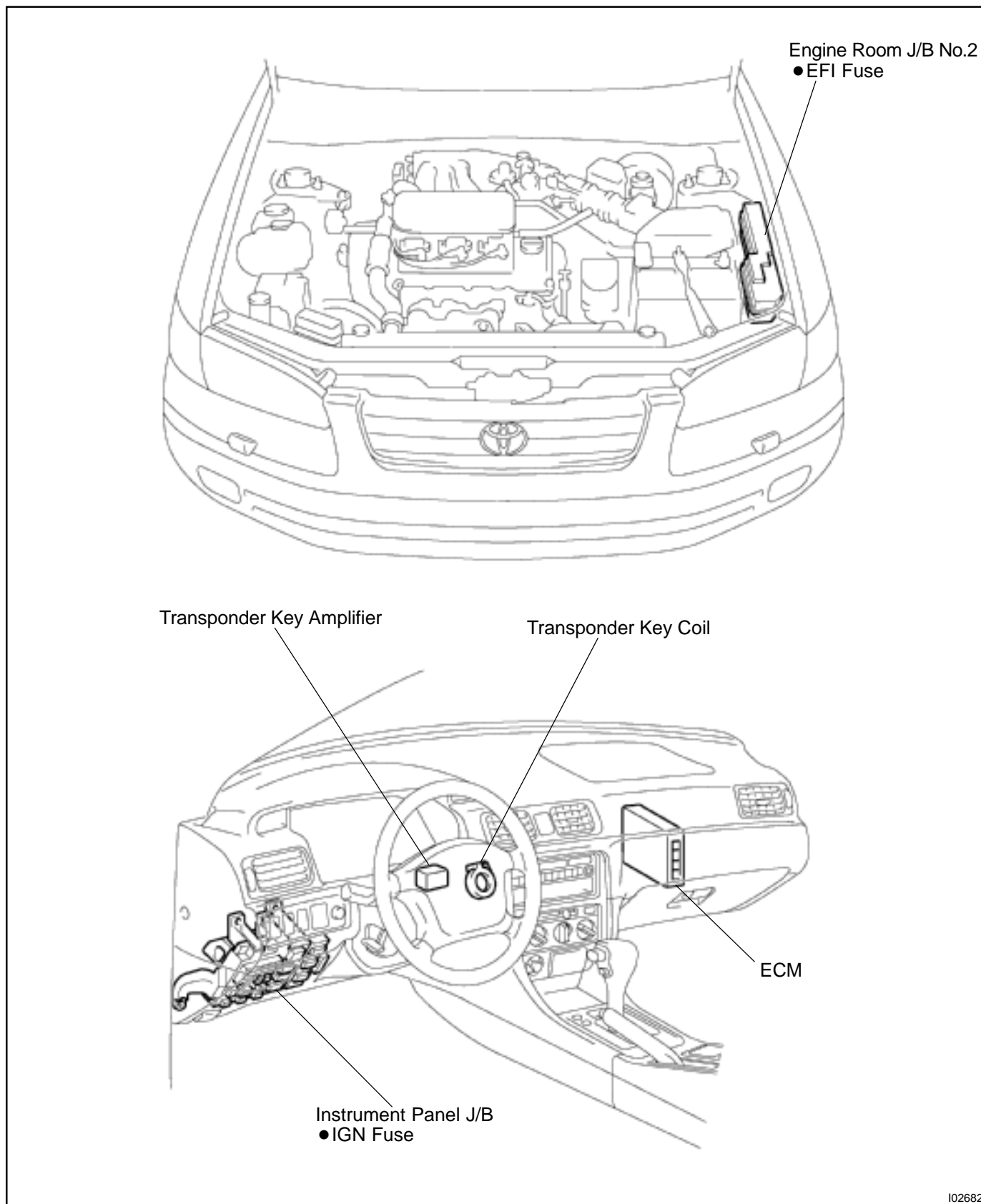

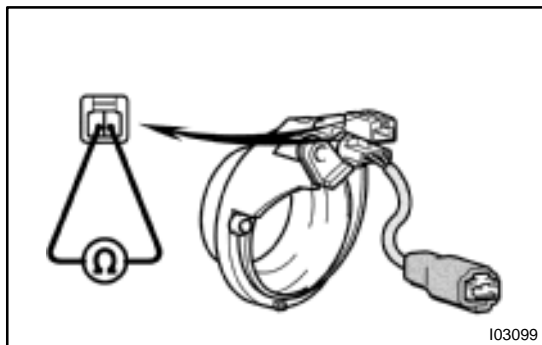

INSPECTION

INSPECTION TRANSPONDER KEY COIL CONTINUITY

Check that continuity exists between terminal 1 and 2.

If continuity is not as specified, replace the coil.