

CO/HC INSPECTION

EM07X-05

HINT:

This check is used only to determine whether or not the idle CO/HC complies with regulations.

1. INITIAL CONDITIONS

- (a) Engine at normal operating temperature
- (b) Air cleaner installed
- (c) All pipes and hoses of air induction system connected
- (d) All accessories switched OFF
- (e) All vacuum lines properly connected

HINT:

All vacuum hoses for EGR system, etc. should be properly connected.

- (f) SFI system wiring connectors fully plugged
- (g) Ignition timing checked correctly
- (h) Transmission in neutral position
- (i) Tachometer and CO/HC meter calibrated by hand

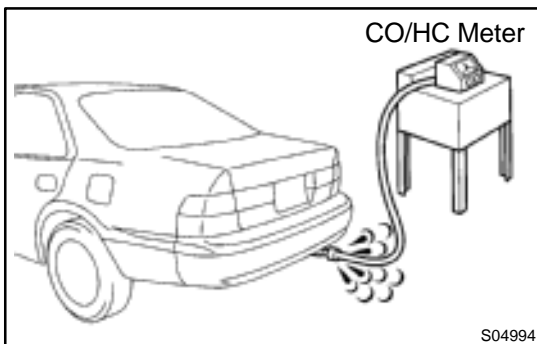

2. START ENGINE

3. RACE ENGINE AT 2,500 RPM FOR APPROX. 180 SECONDS

4. INSERT CO/HC METER TESTING PROBE AT LEAST 40 cm (1.3 ft) INTO TAILPIPE DURING IDLING

5. IMMEDIATELY CHECK CO/HC CONCENTRATION AT IDLE AND/OR 2,500 RPM

Complete the measuring within 3 minutes.

HINT:

When performing the 2 mode (2,500 rpm and idle) test, follow the measurement order prescribed by the applicable local regulations.

If the CO/HC concentration does not comply with regulations, troubleshoot in the order given below.

- (1) Check oxygen sensor operation.
(See page [DI-66](#))
- (2) See the table below for possible causes, then inspect and correct the applicable causes if necessary.

CO	HC	Symptom	Causes
Normal	High	Rough idle	<ol style="list-style-type: none"> 1. Faulty ignitions: Incorrect timing Fouled, shorted or improperly gapped plugs Open or crossed high-tension cords 2. Incorrect valve clearance 3. Leaky EGR valve 4. Leaky intake and exhaust valves 5. Leaky cylinder
Low	High	Rough idle (Fluctuating HC reading)	<ol style="list-style-type: none"> 1. Vacuum leaks: PCV hose EGR valve Intake manifold Throttle body IAC valve Brake booster line 2. Lean mixture causing misfire
High	High	Rough idle (Black smoke from exhaust)	<ol style="list-style-type: none"> 1. Restricted air filter 2. Faulty SFI system Faulty pressure regulator Defective ECT sensor Defective IAT sensor Faulty ECM Faulty injector Faulty throttle position sensor MAP sensor

COMPRESSION INSPECTION

EM07Y-05

HINT:

If there is lack of power, excessive oil consumption or poor fuel economy, measure the compression pressure.

1. WARM UP AND STOP ENGINE

Allow the engine to warm up to normal operating temperature.

2. DISCONNECT IGNITION COIL CONNECTORS

3. REMOVE SPARK PLUGS (See page IG-1)

4. INSPECT CYLINDER COMPRESSION PRESSURE

- (a) Insert a compression gauge into the spark plug hole.
- (b) Fully open the throttle.
- (c) While cranking the engine, measure the compression pressure.

HINT:

Always use a fully charged battery to obtain engine speed of 250 rpm or more.

- (d) Repeat steps (a) through (c) for each cylinder.

NOTICE:

This measurement must be done in as short a time as possible.

Compression pressure:

1,226 kPa (12.5 kgf/cm², 178 psi) or more

Minimum pressure: 981 kPa (10.0 kgf/cm², 142 psi)

Difference between each cylinder:

98 kPa (1.0 kgf/cm², 14 psi) or less

- (e) If the cylinder compression in one or more cylinders is low, pour a small amount of engine oil into the cylinder through the spark plug hole and repeat steps (a) through (c) for cylinders with low compression.

If adding oil helps the compression, it is likely that the piston rings and/or cylinder bore are worn or damaged.

If pressure stays low, a valve may be sticking or seating is improper, or there may be leakage past the gasket.

5. REINSTALL SPARK PLUGS (See page IG-1)

6. RECONNECT IGNITION COIL CONNECTORS

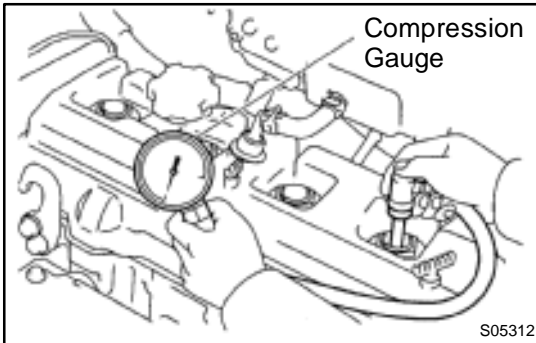

VALVE CLEARANCE INSPECTION

EM07Z-03

HINT:

Inspect and adjust the valve clearance when the engine is cold.

1. REMOVE CYLINDER HEAD COVER

- Disconnect the 4 high-tension cords from the clamps on the cylinder head cover.
- Disconnect the 4 high-tension cords from the spark plugs.
- Disconnect the PCV hose from the intake manifold.
- Disconnect the PCV hose from the cylinder head cover.
- Disconnect the engine wire clamp from the mounting bolt of the No.2 timing belt cover.
- Remove the cylinder head cover. (See page EM-33)

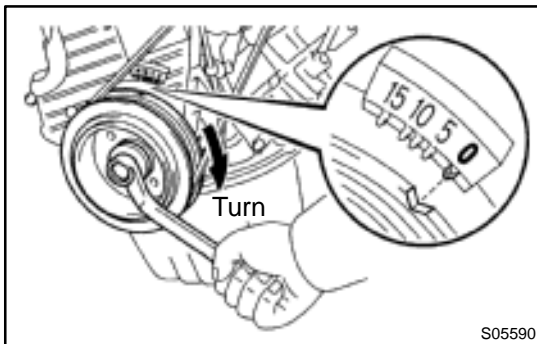
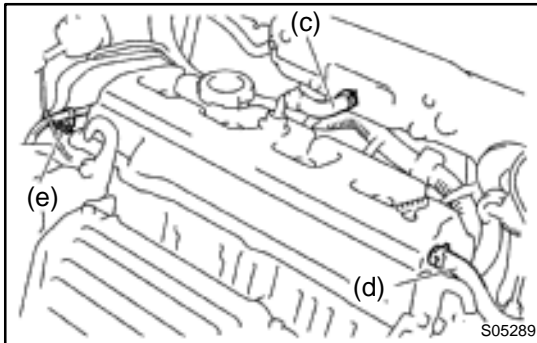

2. SET NO.1 CYLINDER TO TDC/COMPRESSION

- Turn the crankshaft pulley, and align its groove with timing mark "0" of the No.1 timing belt cover.
- Check that the valve lifters on the No.1 cylinder are loose and valve lifters on the No.4 are tight.

If not, turn the crankshaft one revolution (360°) and align the mark as above.

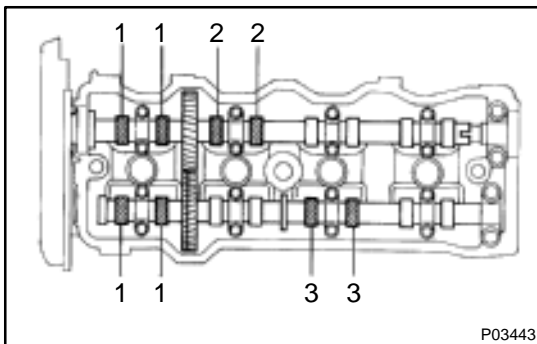

3. INSPECT VALVE CLEARANCE

- Check only the valves indicated.
 - Using a feeler gauge, measure the clearance between the valve lifter and camshaft.
 - Record the out-of-specification valve clearance measurements. They will be used later to determine the required replacement adjusting shim.

Valve clearance (Cold):

Intake	0.19 – 0.29 mm (0.007 – 0.011 in.)
Exhaust	0.28 – 0.38 mm (0.011 – 0.015 in.)

- Turn the crankshaft one revolution (360°) and align the mark as above.

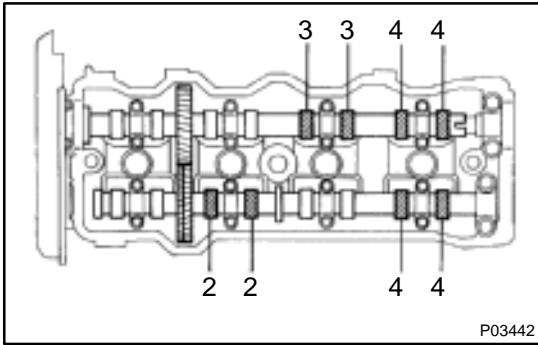

(c) Check only the valves indicated as shown. Measure the valve clearance. (See step (a))

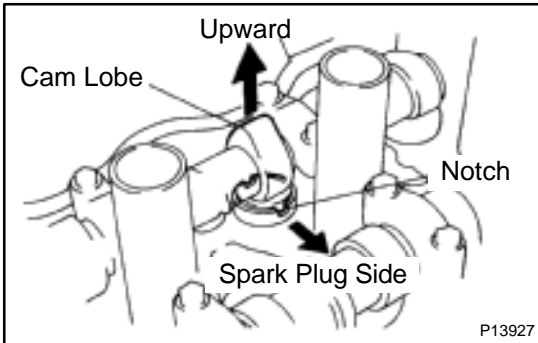

4. ADJUST VALVE CLEARANCE

- (a) Remove the adjusting shim.
- (1) Turn the crankshaft so that the cam lobe of the camshaft on the adjusting valve points upward.
 - (2) Position the notch of the valve lifter facing the spark plug side.

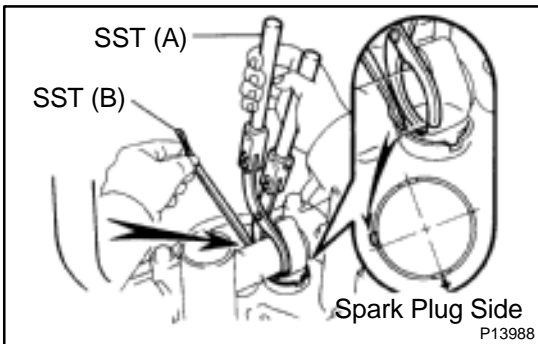

- (3) Using SST (A), press down the valve lifter and place SST (B) between the camshaft and valve lifter. Remove SST (A).

SST 09248-55040 (09248-05410, 09248-05420)

HINT:

Apply SST (B) at slight angle on the side marked with "9", at the position shown in the illustration.

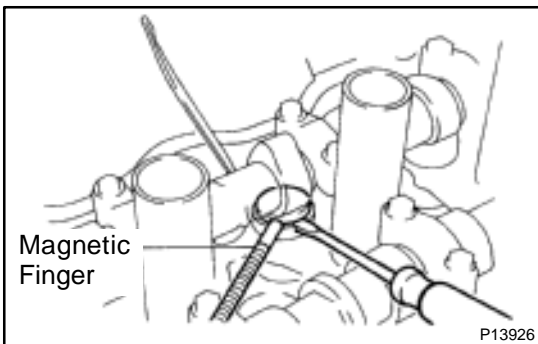

- (4) Remove the adjusting shim with a small screwdriver and magnetic finger.

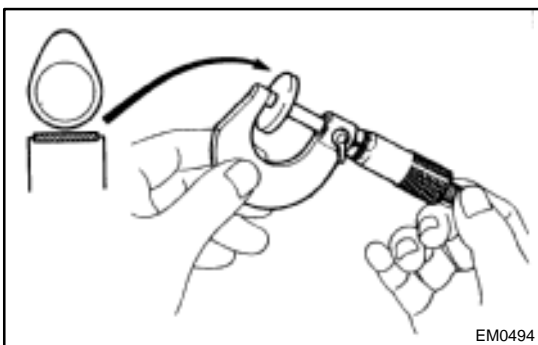

(b) Determine the replacement adjusting shim size by following the Formula or Charts:

- (1) Using a micrometer, measure the thickness of the removed shim.
- (2) Calculate the thickness of a new shim so that the valve clearance comes within specified value.

T Thickness of removed shim
 A Measured valve clearance
 N Thickness of new shim

Intake: $N = T + (A - 0.24 \text{ mm (0.009 in.)})$

Exhaust: $N = T + (A - 0.33 \text{ mm (0.013 in.)})$

- (3) Select a new shim with a thickness as close as possible to the calculated value.

HINT:

Shims are available in 17 sizes in increments of 0.05 mm (0.0020 in.), from 2.50 mm (0.0984 in.) to 3.30 mm (0.1299 in.).

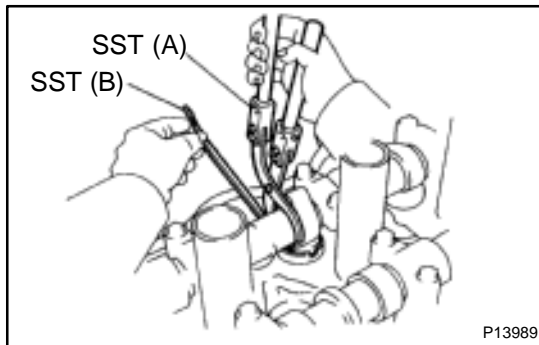

- (c) Install a new adjusting shim.
- (1) Place a new adjusting shim on the valve lifter.
 - (2) Using SST (A), press down the valve lifter and remove SST (B).
- SST 09248-55040 (09248-05410, 09248-05420)
- (d) Recheck the valve clearance.

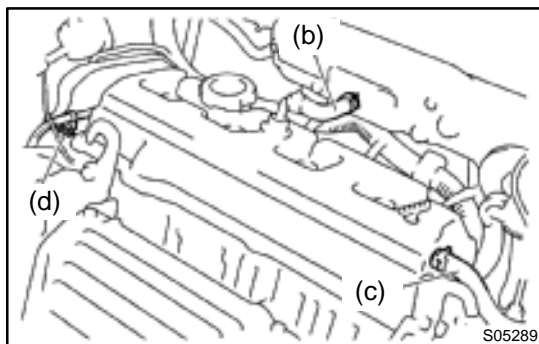
**5. REINSTALL CYLINDER HEAD COVER**

- (a) Install the cylinder head cover. (See page EM-53)
- (b) Connect the PCV hose to the intake manifold.
- (c) Connect the PCV hose to the cylinder head cover.
- (d) Install the engine wire clamp to the mounting bolt of the No.2 timing belt cover.
- (e) Install the 4 high-tension cords to the clamps on the cylinder head cover.
- (f) Connect the 4 high-tension cords to the spark plugs.

Adjusting Shim Selection Chart (Intake)

Installed shim thickness mm (in.)																			
Measured clearance mm (in.)	2.650 (0.1043)	2.620 (0.1031)	2.590 (0.1019)	2.560 (0.1007)	2.530 (0.0995)	2.500 (0.0983)	2.470 (0.0971)	2.440 (0.0959)	2.410 (0.0947)	2.380 (0.0935)	2.350 (0.0923)	2.320 (0.0911)	2.290 (0.0899)	2.260 (0.0887)	2.230 (0.0875)	2.200 (0.0863)	2.170 (0.0851)	2.140 (0.0839)	
0.000 - 0.020 (0.0000 - 0.0008)																			
0.021 - 0.040 (0.0008 - 0.0016)																			
0.041 - 0.060 (0.0016 - 0.0024)																			
0.061 - 0.080 (0.0024 - 0.0031)																			
0.081 - 0.100 (0.0032 - 0.0039)																			
0.101 - 0.120 (0.0040 - 0.0047)																			
0.121 - 0.140 (0.0048 - 0.0055)																			
0.141 - 0.160 (0.0055 - 0.0062)																			
0.161 - 0.180 (0.0063 - 0.0071)																			
0.181 - 0.199 (0.0071 - 0.0074)																			
0.199 - 0.219 (0.0075 - 0.0114)																			
0.219 - 0.239 (0.0115 - 0.0118)																			
0.239 - 0.259 (0.0119 - 0.0126)																			
0.259 - 0.279 (0.0126 - 0.0134)																			
0.279 - 0.299 (0.0134 - 0.0142)																			
0.299 - 0.319 (0.0142 - 0.0150)																			
0.319 - 0.339 (0.0150 - 0.0157)																			
0.339 - 0.359 (0.0158 - 0.0165)																			
0.359 - 0.379 (0.0166 - 0.0173)																			
0.379 - 0.399 (0.0174 - 0.0181)																			
0.399 - 0.419 (0.0181 - 0.0188)																			
0.419 - 0.439 (0.0189 - 0.0197)																			
0.439 - 0.459 (0.0197 - 0.0205)																			
0.459 - 0.479 (0.0205 - 0.0213)																			
0.479 - 0.499 (0.0213 - 0.0221)																			
0.499 - 0.519 (0.0221 - 0.0228)																			
0.519 - 0.539 (0.0229 - 0.0236)																			
0.539 - 0.559 (0.0237 - 0.0244)																			
0.559 - 0.579 (0.0244 - 0.0252)																			
0.579 - 0.599 (0.0252 - 0.0260)																			
0.599 - 0.619 (0.0260 - 0.0268)																			
0.619 - 0.639 (0.0268 - 0.0275)																			
0.639 - 0.659 (0.0276 - 0.0283)																			
0.659 - 0.679 (0.0284 - 0.0291)																			
0.679 - 0.699 (0.0292 - 0.0299)																			
0.699 - 0.719 (0.0300 - 0.0307)																			
0.719 - 0.739 (0.0307 - 0.0315)																			
0.739 - 0.759 (0.0315 - 0.0322)																			
0.759 - 0.779 (0.0323 - 0.0331)																			
0.779 - 0.799 (0.0331 - 0.0339)																			
0.799 - 0.819 (0.0339 - 0.0346)																			
0.819 - 0.839 (0.0347 - 0.0354)																			
0.839 - 0.859 (0.0355 - 0.0362)																			
0.859 - 0.879 (0.0363 - 0.0370)																			
0.879 - 0.899 (0.0370 - 0.0378)																			
0.899 - 0.919 (0.0378 - 0.0385)																			
0.919 - 0.939 (0.0386 - 0.0394)																			
0.939 - 0.959 (0.0394 - 0.0402)																			
0.959 - 0.979 (0.0402 - 0.0409)																			
0.979 - 0.999 (0.0410 - 0.0417)																			
0.999 - 1.019 (0.0418 - 0.0425)																			
1.019 - 1.039 (0.0426 - 0.0433)																			

Intake valve clearance (Cold):
0.19 – 0.29 mm (0.007 – 0.011 in.)

EXAMPLE: The 2.800 mm (0.1102 in.) shim is installed, and the measured clearance is 0.450 mm (0.0177 in.). Replace the 2.800 mm (0.1102 in.) shim with a new No.11 shim.

New shim thickness mm (in.)			
Shim No.	Thickness	Shim No.	Thickness
1	2.500 (0.0984)	10	2.950 (0.1161)
2	2.550 (0.1004)	11	3.000 (0.1181)
3	2.600 (0.1024)	12	3.050 (0.1201)
4	2.650 (0.1043)	13	3.100 (0.1220)
5	2.700 (0.1063)	14	3.150 (0.1240)
6	2.750 (0.1083)	15	3.200 (0.1260)
7	2.800 (0.1102)	16	3.250 (0.1280)
8	2.850 (0.1122)	17	3.300 (0.1299)
9	2.900 (0.1142)		

HINT: New shims have the thickness in millimeters imprinted on the face.

Adjusting Shim Selection Chart (Exhaust)

Installed shim thickness mm (in.)	Measured clearance mm (in.)	New shim thickness mm (in.)																		
		2.500 (0.0984)	2.550 (0.1004)	2.600 (0.1024)	2.650 (0.1043)	2.700 (0.1063)	2.750 (0.1083)	2.800 (0.1102)	2.850 (0.1122)	2.900 (0.1142)	2.950 (0.1161)	3.000 (0.1181)	3.050 (0.1201)	3.100 (0.1220)	3.150 (0.1240)	3.200 (0.1260)	3.250 (0.1280)	3.300 (0.1299)	3.350 (0.1319)	3.400 (0.1339)
0.000 - 0.020 (0.0000 - 0.0008)																				
0.021 - 0.040 (0.0028 - 0.0016)																				
0.041 - 0.060 (0.0016 - 0.0024)																				
0.061 - 0.080 (0.0024 - 0.0031)																				
0.081 - 0.100 (0.0032 - 0.0039)																				
0.101 - 0.120 (0.0040 - 0.0047)																				
0.121 - 0.140 (0.0048 - 0.0055)																				
0.141 - 0.160 (0.0056 - 0.0063)																				
0.161 - 0.180 (0.0063 - 0.0071)																				
0.181 - 0.200 (0.0071 - 0.0079)																				
0.201 - 0.220 (0.0079 - 0.0087)																				
0.221 - 0.240 (0.0087 - 0.0094)																				
0.241 - 0.260 (0.0095 - 0.0102)																				
0.261 - 0.279 (0.0103 - 0.0110)																				
0.280 - 0.380 (0.0110 - 0.0150)																				
0.381 - 0.400 (0.0150 - 0.0157)																				
0.401 - 0.420 (0.0158 - 0.0165)																				
0.421 - 0.440 (0.0166 - 0.0173)																				
0.441 - 0.460 (0.0174 - 0.0181)																				
0.461 - 0.480 (0.0181 - 0.0189)																				
0.481 - 0.500 (0.0189 - 0.0197)																				
0.501 - 0.520 (0.0197 - 0.0205)																				
0.521 - 0.540 (0.0205 - 0.0213)																				
0.541 - 0.560 (0.0213 - 0.0220)																				
0.561 - 0.580 (0.0221 - 0.0228)																				
0.581 - 0.600 (0.0229 - 0.0236)																				
0.601 - 0.620 (0.0237 - 0.0244)																				
0.621 - 0.640 (0.0244 - 0.0252)																				
0.641 - 0.660 (0.0252 - 0.0260)																				
0.661 - 0.680 (0.0260 - 0.0268)																				
0.681 - 0.700 (0.0268 - 0.0276)																				
0.701 - 0.720 (0.0276 - 0.0283)																				
0.721 - 0.740 (0.0284 - 0.0291)																				
0.741 - 0.760 (0.0292 - 0.0299)																				
0.761 - 0.780 (0.0300 - 0.0307)																				
0.781 - 0.800 (0.0307 - 0.0315)																				
0.801 - 0.820 (0.0315 - 0.0323)																				
0.821 - 0.840 (0.0323 - 0.0331)																				
0.841 - 0.860 (0.0331 - 0.0339)																				
0.861 - 0.880 (0.0339 - 0.0346)																				
0.881 - 0.900 (0.0347 - 0.0354)																				
0.901 - 0.920 (0.0355 - 0.0362)																				
0.921 - 0.940 (0.0363 - 0.0370)																				
0.941 - 0.960 (0.0370 - 0.0378)																				
0.961 - 0.980 (0.0378 - 0.0385)																				
0.981 - 1.000 (0.0386 - 0.0394)																				
1.001 - 1.020 (0.0394 - 0.0402)																				
1.021 - 1.040 (0.0402 - 0.0409)																				
1.041 - 1.060 (0.0410 - 0.0417)																				
1.061 - 1.080 (0.0418 - 0.0425)																				
1.081 - 1.100 (0.0426 - 0.0433)																				
1.101 - 1.120 (0.0433 - 0.0441)																				
1.121 - 1.140 (0.0441 - 0.0449)																				
1.141 - 1.160 (0.0449 - 0.0457)																				
1.161 - 1.180 (0.0457 - 0.0465)																				

**Exhaust valve clearance (Cold):
0.28 – 0.38 mm (0.011 – 0.015 in.)**

EXAMPLE: The 2.800 mm (0.1102 in.) shim is installed, and the measured clearance is 0.450 mm (0.0177 in.). Replace the 2.800 mm (0.1102 in.) shim with a new No.6 shim.

New shim thickness mm (in.)			
Shim No.	Thickness	Shim No.	Thickness
1	2.500 (0.0984)	10	2.950 (0.1161)
2	2.550 (0.1004)	11	3.000 (0.1181)
3	2.600 (0.1024)	12	3.050 (0.1201)
4	2.650 (0.1043)	13	3.100 (0.1220)
5	2.700 (0.1063)	14	3.150 (0.1240)
6	2.750 (0.1083)	15	3.200 (0.1260)
7	2.800 (0.1102)	16	3.250 (0.1280)
8	2.850 (0.1122)	17	3.300 (0.1299)
9	2.900 (0.1142)		

HINT: New shims have the thickness in millimeters imprinted on the face.

Author :

Date :

1180

V00868

P63441

IGNITION TIMING INSPECTION

EM080-03

1. WARM UP ENGINE

Allow the engine to warm up to normal operating temperature.

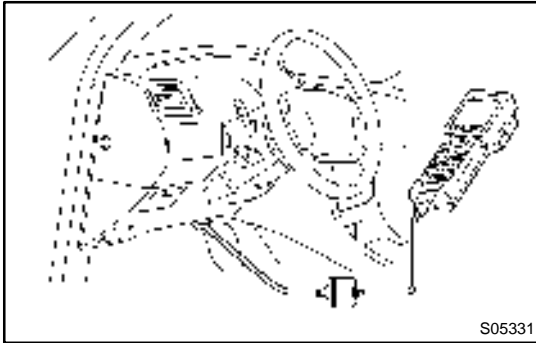

2. CONNECT TOYOTA HAND-HELD TESTER OR OBDII SCAN TOOL

- Remove the fuse cover on the instrument panel.
- Connect a TOYOTA hand-held tester or OBDII scan tool to the DLC3.
- Please refer to the TOYOTA hand-held tester or OBDII scan tool operator's manual for further details.

3. CONNECT TIMING LIGHT TO ENGINE

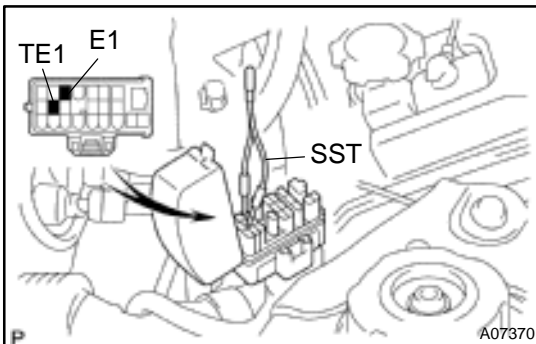

4. INSPECT IGNITION TIMING

- Using SST, connect terminals TE1 and E1 of the DLC1.
SST 09843-18020

HINT:

After engine rpm is kept at 1,000 – 1,300 rpm for 5 seconds, check that it returns to idle speed.



- Using a timing light, check the ignition timing.

**Ignition timing: 8 – 12° BTDC @ idle
(Transmission in neutral position)**

- Remove the SST from the DLC1.
SST 09843-18020

5. FURTHER CHECK IGNITION TIMING

**Ignition timing: 0 – 10° BTDC @ idle
(Transmission in neutral position)**

HINT:

The timing mark moves in a range between 0° and 10°.

6. DISCONNECT TIMING LIGHT FROM ENGINE

7. DISCONNECT TOYOTA HAND-HELD TESTER OR OBDII SCAN TOOL

IDLE SPEED INSPECTION

EM081-05

1. INITIAL CONDITIONS

- (a) Engine at normal operating temperature
- (b) Air cleaner installed
- (c) All pipes and hoses of air induction system connected
- (d) All vacuum lines properly connected
- (e) SFI system wiring connectors fully plugged
- (f) All operating accessories switched OFF
- (g) Ignition timing check correctly
- (h) Transmission in neutral position
- (i) Air conditioning switched OFF

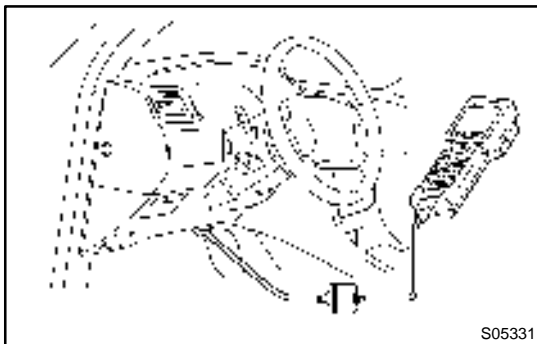

2. CONNECT TOYOTA HAND-HELD TESTER OR OBDII SCAN TOOL

- (a) Remove the fuse cover on the instrument panel.
- (b) Connect a TOYOTA hand-held tester or OBDII scan tool to the DLC3.
- (c) Please refer to the TOYOTA hand-held tester or OBDII scan tool operator's manual for further details.

3. INSPECT IDLE SPEED

- (a) Race the engine at 2,500 rpm for approx. 90 seconds.
- (b) Check the idle speed.

Idle speed (w/ Cooling fan OFF): 700 ± 50 rpm

If the idle speed is not as specified, check the IAC valve and air intake system.

4. DISCONNECT TOYOTA HAND-HELD TESTER OR OBDII SCAN TOOL

BALANCE SHAFT BACKLASH ON-VEHICLE INSPECTION

EM082-04

1. REMOVE OIL PAN AND OIL STRAINER
(See page LU-7)

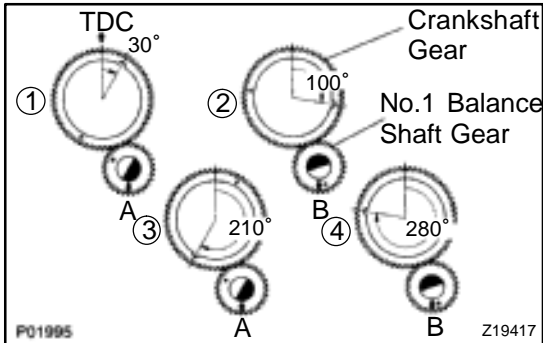

2. INSPECT BACKLASH OF CRANKSHAFT GEAR AND NO.1 BALANCE SHAFT GEAR

NOTICE:

Backlash between the crankshaft gear and No.1 balance shaft gear varies with the rotation of the balance shaft and the deviation of the crankshaft gear. Accordingly, it is necessary to measure the backlash at the 4 points shown in the illustration on the left.

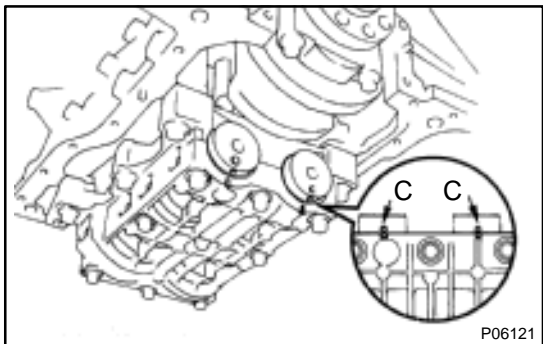

- (a) Turn the crankshaft 2 or 3 times to settle the crankshaft gear and No.1 balance shaft gear.
- (b) When No.1 piston is at TDC, check that the punch marks C shown in the illustration of the balance shafts are aligned with the grooves of the No.2 housing.

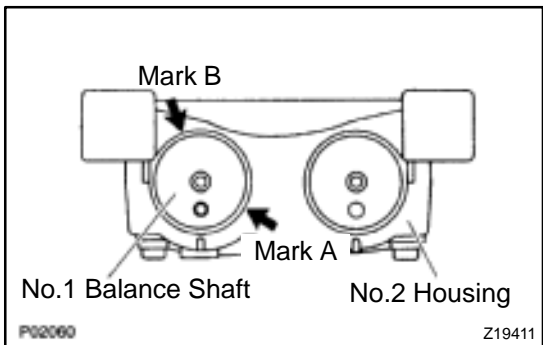

- (c) Check that punch marks A and B are at the positions on the No.1 balance shaft indicated in the illustration.

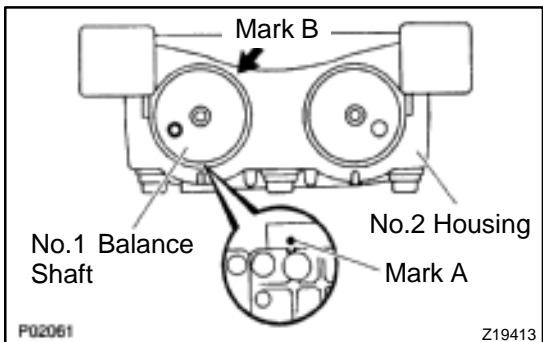

- (d) First turn the crankshaft clockwise, and align the groove of the No.2 balance shaft housing with punch mark A of the No.1 balance shaft.

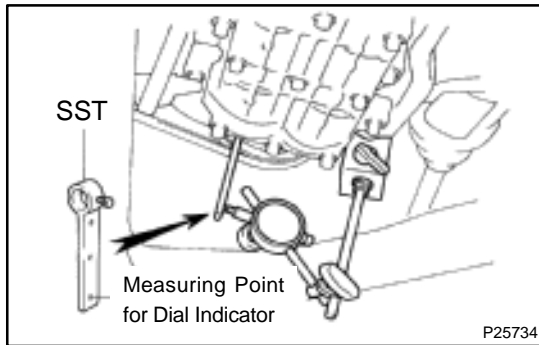

- (e) Set SST and a dial indicator as shown in the illustration.
SST 09224-74010

HINT:

Make sure that the stem of the dial indicator is perpendicular to the SST and that it is placed in the middle of the 3rd indentation.

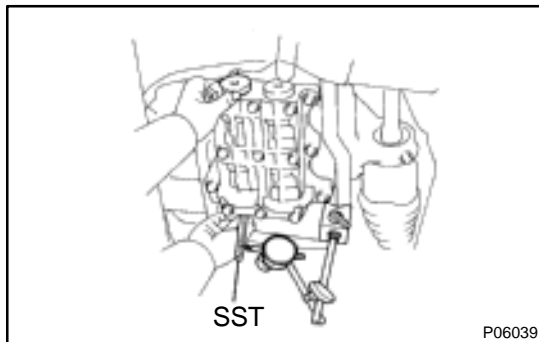

- (f) Lightly turn the No.1 balance shaft by hand until resistance is felt, and measure the backlash.

HINT:

Turn the No.1 balance shaft 4 or 5 times to provide a steady backlash reading.

To prevent excessive backlash due to thrust clearance, measure the backlash while pressing on the rear of the No.1 balance shaft.

Standard backlash (at punch mark A):
0.025 – 0.065 mm (0.0010 – 0.0026 in.)

NOTICE:

Do not turn the No.1 balance shaft strongly.

- (g) Remove the dial indicator and SST.

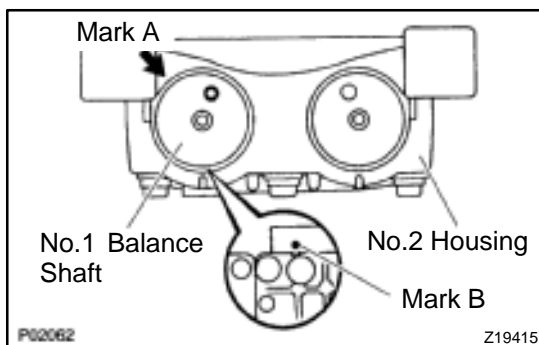

- (h) Turn the crankshaft clockwise to align the groove of the No.2 housing with punch mark B.

- (i) Set the dial indicator. (See step (e))

- (j) Measure the backlash. (See step (f))

Standard backlash (at punch mark B):
0.025 – 0.085 mm (0.0010 – 0.0033 in.)

- (k) Remove the dial indicator.

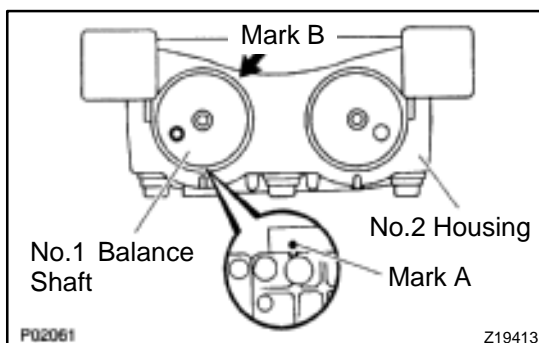

- (l) Turn the crankshaft clockwise again to align the groove of the No.2 housing with punch mark A.

- (m) Set the dial indicator. (See step (e))

- (n) Measure the backlash. (See step (f))

Standard backlash (at punch mark A):
0.025 – 0.065 mm (0.0010 – 0.0026 in.)

- (o) Remove the dial indicator.

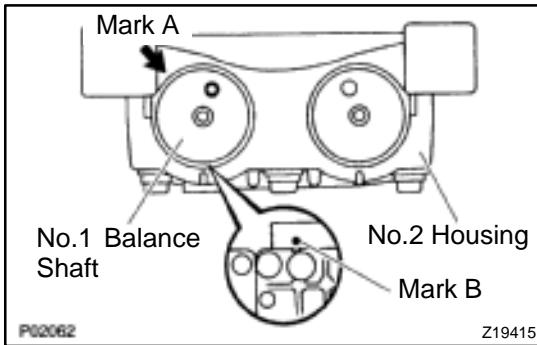

- (p) Turn the crankshaft clockwise again to align the groove of the No.2 housing with punch mark B.
- (q) Set the dial indicator. (See step (e))
- (r) Measure the backlash. (See step (f))

Standard backlash (at punch mark B):
0.025 – 0.085 mm (0.0010 – 0.0033 in.)

- (s) Remove the dial indicator.

If even one of the 4 points measured above exceeds the backlash specification, adjust the backlash with new spacers.

NOTICE:

Use the same size spacers for both the left and right sides.

HINT:

Varying the spacer thickness by 0.02 mm (0.0008 in.) changes the backlash by about 0.014 mm (0.0006 in.).

If the backlash is greater than the permitted maximum, select a thinner shim.

If the backlash is less than the specification, select a thicker shim.

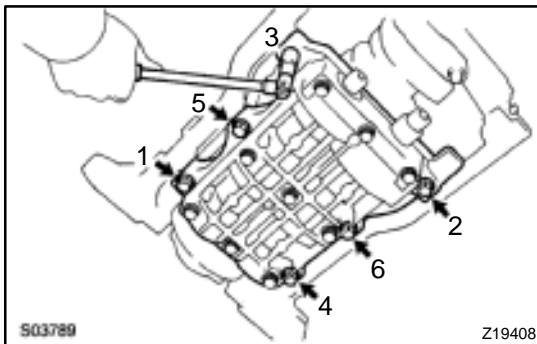

3. REPLACE NEW SPACERS

- (a) Uniformly loosen the 6 bolts in the sequence shown.
- (b) Replace the spacers with new ones.

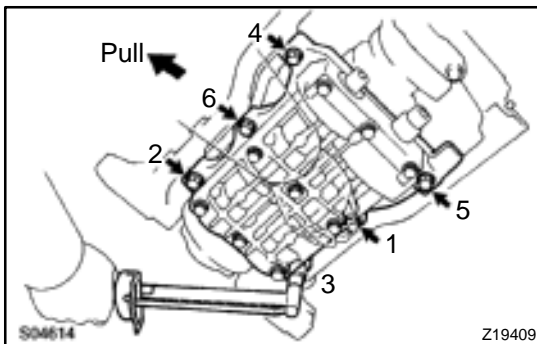

4. TIGHTEN BALANCE SHAFT ASSEMBLY

While pulling the center part of the engine balancer in the direction of the arrow, uniformly tighten the 6 bolts in several passes, in the sequence shown.

Torque: 49 N·m (500 kgf·cm, 36 ft·lbf)

- 5. INSPECT AND ADJUST BACKLASH OF CRANKSHAFT GEAR AND NO.1 BALANCE SHAFT GEAR (See step 2)**
- 6. REINSTALL OIL STRAINER AND OIL PAN (See page LU-13)**

TIMING BELT COMPONENTS

EM083-03

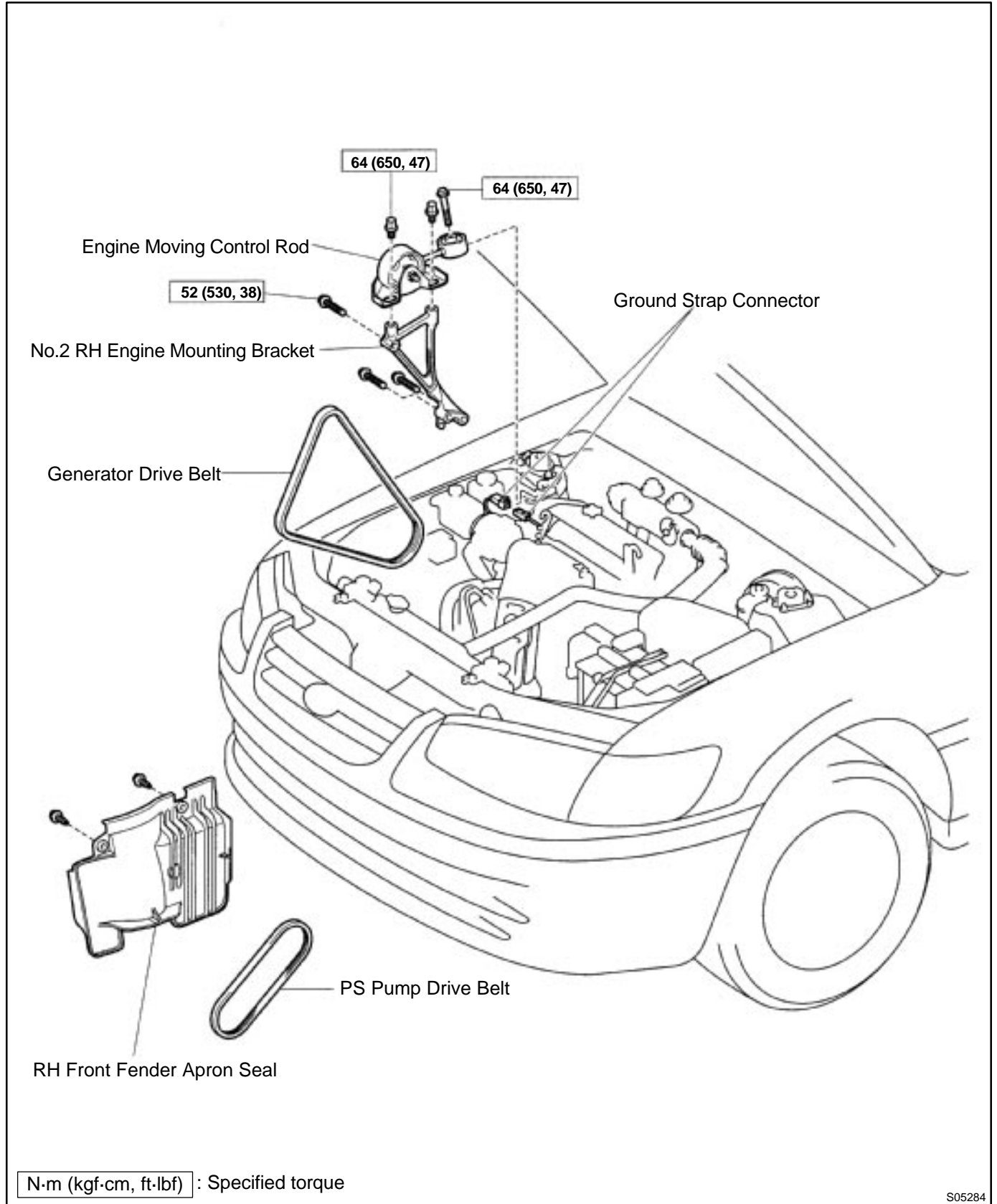

S05284

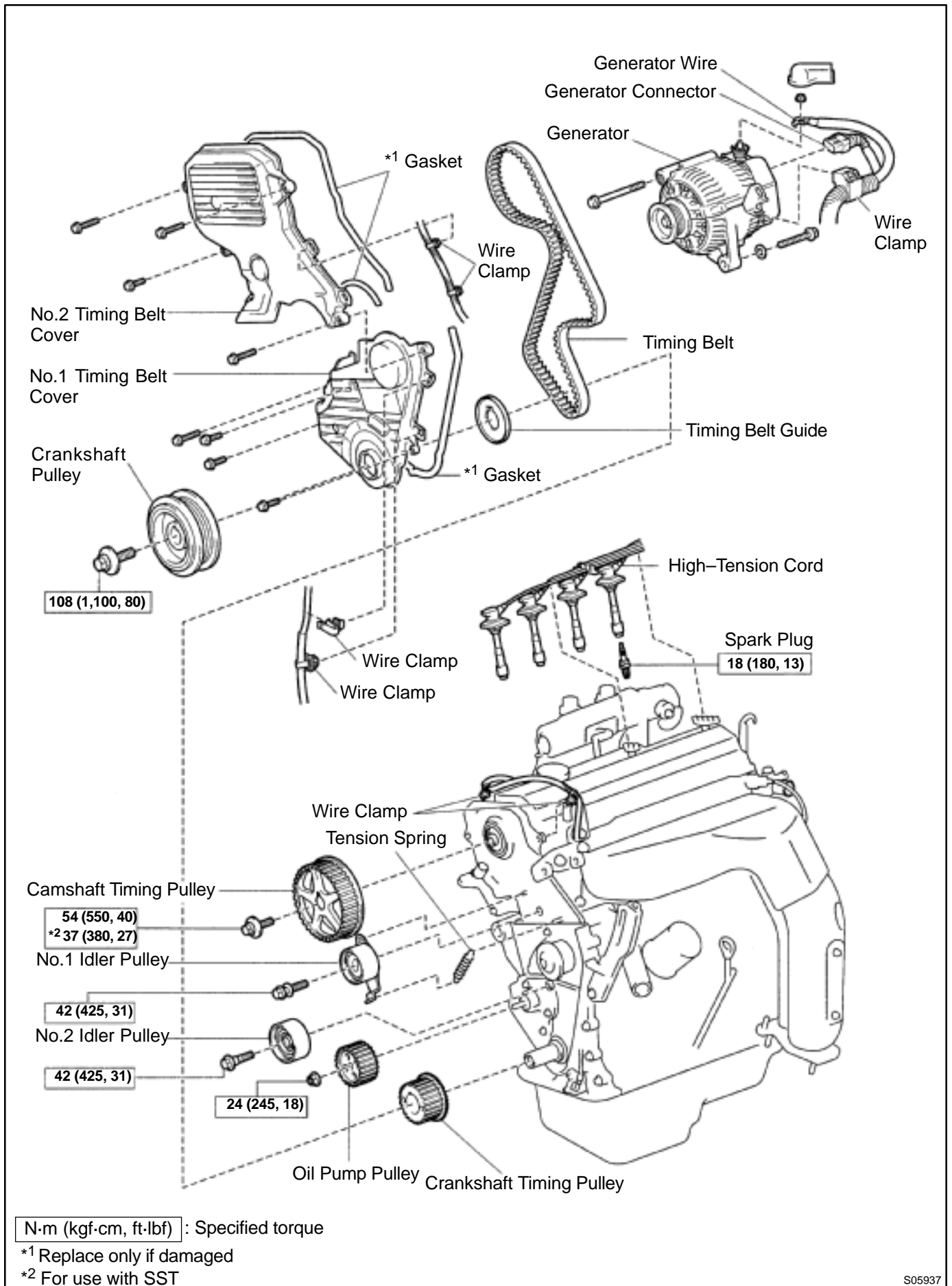

S05937

REMOVAL

1. REMOVE GENERATOR (See page CH-6)
2. REMOVE RH FRONT WHEEL
3. REMOVE RH FRONT FENDER APRON SEAL

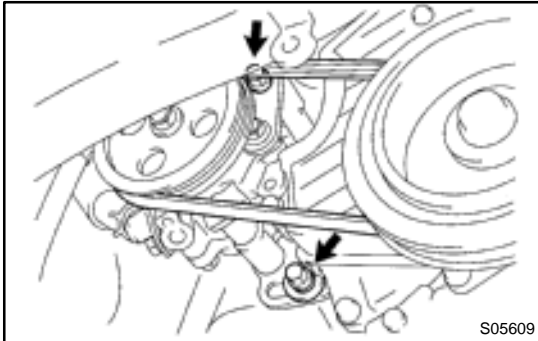

4. REMOVE PS PUMP DRIVE BELT
Loosen the 2 bolts, and remove the drive belt.
5. DISCONNECT GROUND STRAP CONNECTOR

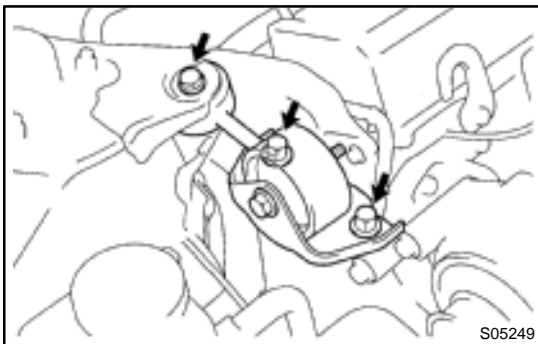

6. REMOVE ENGINE MOVING CONTROL ROD
Remove the 3 bolts and control rod.

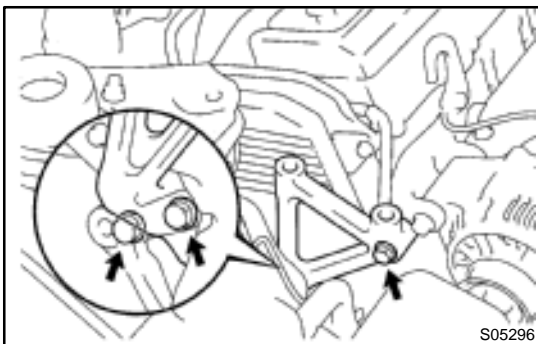

7. REMOVE NO.2 RH ENGINE MOUNTING BRACKET
Remove the 3 bolts and mounting bracket.

8. REMOVE SPARK PLUGS

- (a) Disconnect the 4 high-tension cords from the clamps on the cylinder head cover.
- (b) Disconnect the 4 high-tension cords from the spark plug.
- (c) Remove the 4 spark plugs.

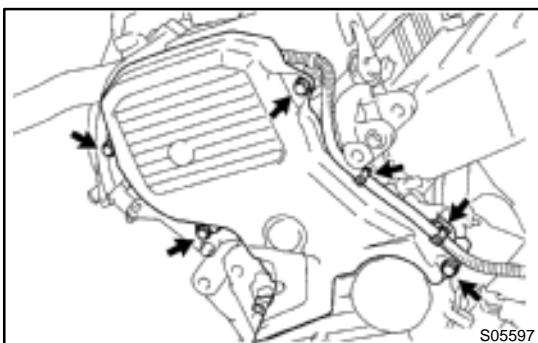

9. REMOVE NO.2 TIMING BELT COVER
 - (a) Disconnect the 2 engine wire clamps from the timing belt cover.
 - (b) Remove the 4 bolts and timing belt cover.

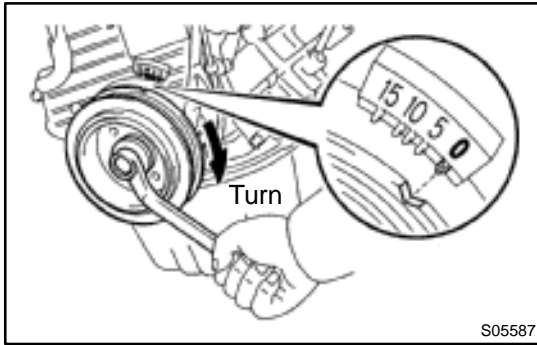
**10. SET NO.1 CYLINDER TO TDC/COMPRESSION**

- (a) Turn the crankshaft pulley, and align its groove with timing mark "0" of the No.1 timing belt cover.

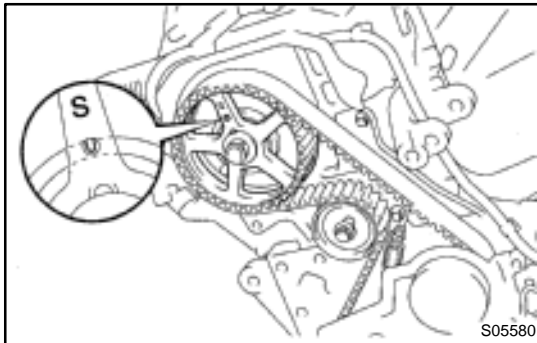

- (b) Check that the hole of the camshaft timing pulley is aligned with the timing mark of the bearing cap. If not, turn the crankshaft 1 revolution (360°).

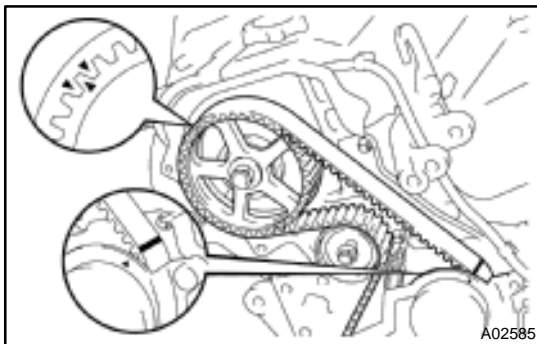
**11. REMOVE TIMING BELT FROM CAMSHAFT TIMING PULLEY****HINT:**

When re-using timing belt:

Affix the matching marks on the timing belt and the camshaft timing pulley, and the timing belt and the No. 1 timing belt cover.

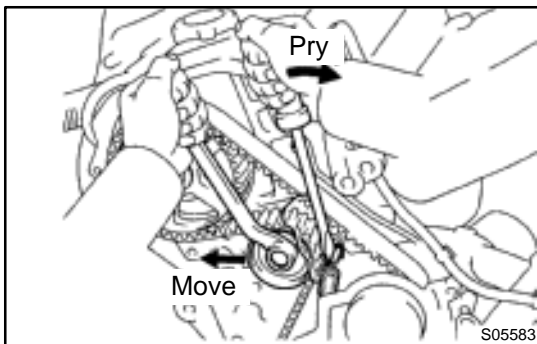

- (a) Loosen the mounting bolt of the No.1 idler pulley, and shift the pulley toward the left as far as it will go, and temporarily tighten it.
- (b) Remove the timing belt from the camshaft timing pulley.

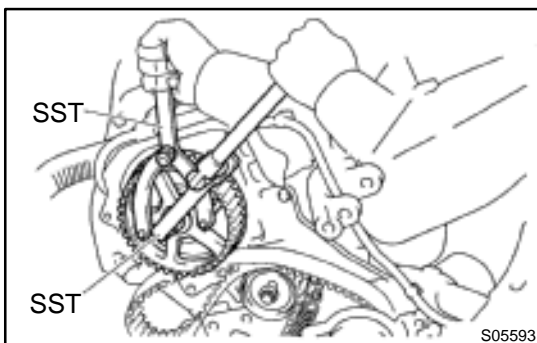
**12. REMOVE CAMSHAFT TIMING PULLEY**

- (a) Using SST, loosen the pulley bolt.
SST 09249-63010, 09960-10010 (09962-01000, 09963-01000)
- (b) Remove the bolt and timing pulley.

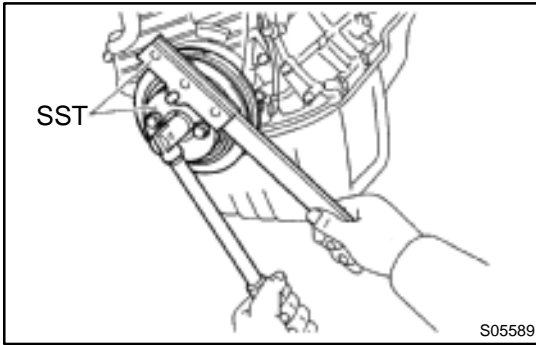

13. REMOVE CRANKSHAFT PULLEY

- (a) Using SST (and bolt), loosen the pulley bolt.
SST 09213-54015 (91651-60855), 09330-00021

HINT:

Either of 2 types of pulley may be used, each with its own bolt size, type A (91651-60885) and type B (part No. 91121-40665).

When using bolt type B, a plate washer must be inserted between the bolt and SST.

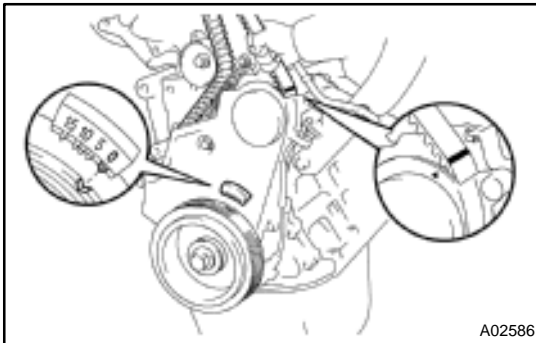

HINT:

When re-using timing belt:

After loosening the crankshaft pulley bolt and matching the ditch of the crankshaft pulley with the "0" of the timing mark of No.1 timing belt cover, check that matching mark meets.

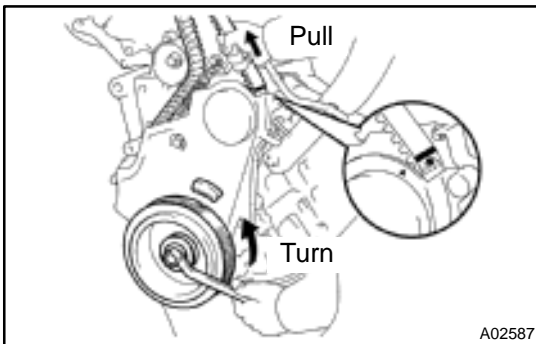

When matchmark is misaligned clockwise:

If the matchmark does not align, align as follows:

- (1) Align the matchmark by pulling the timing belt up on the water pump pulley side while turning the crankshaft pulley counterclockwise.

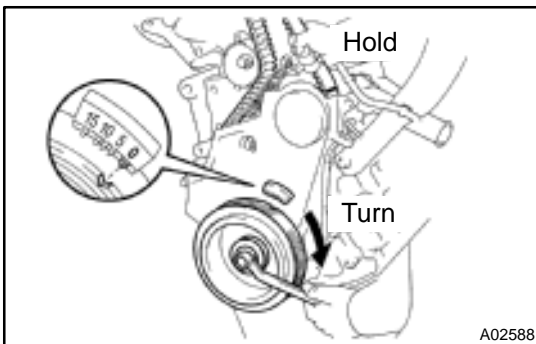

- (2) After aligning the matchmark, hold the timing belt. And turn the crankshaft pulley clockwise, and align its groove with timing mark "0" of the No.1 timing belt cover.

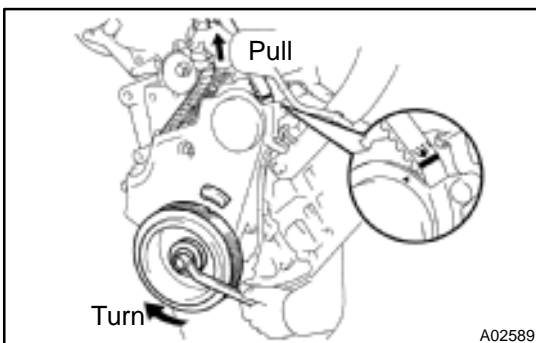

When matchmark is misaligned counterclockwise:

If the matchmark does not align, align as follows:

- (1) Align the matchmark by pulling the timing belt up on the No.1 idler pulley side while turning the crankshaft pulley clockwise.

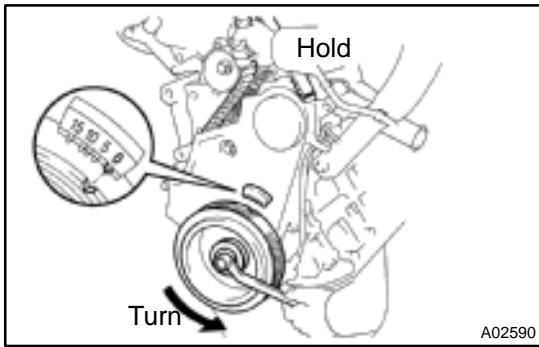

(2) After aligning the matchmark, hold the timing belt. And turn the crankshaft pulley counterclockwise, and align its groove with timing mark "0" of the No.1 timing belt cover.

(b) Remove the pulley bolt.

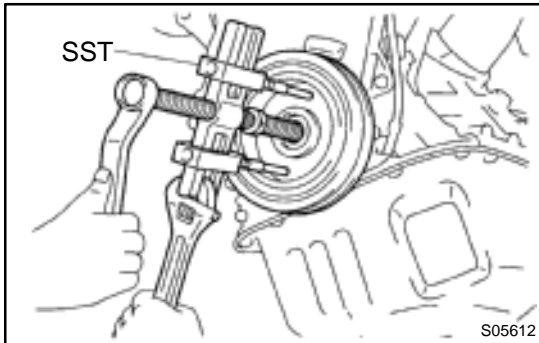

(c) Using SST, remove the pulley.

SST 09950-50012 (09951-05010, 09952-05010, 09953-05010, 09953-05020, 09954-05020, 09954-05010)

HINT:

Either of 2 types of pulley may be used, each with its own bolt size, type A(09954-05020) and type B (09954-05010).

When re-using timing belt:

Remove the pulley without turning it.

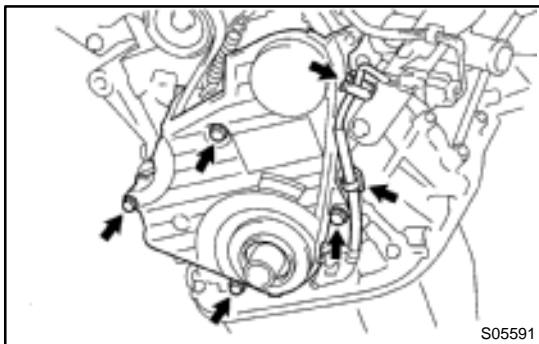

14. REMOVE NO.1 TIMING BELT COVER

(a) Disconnect the crankshaft position sensor wire from the clamp on the timing belt cover.

(b) Disconnect the clamp of the crankshaft position sensor wire from the timing belt cover.

(c) Remove the 4 bolts and timing belt cover.

15. REMOVE TIMING BELT GUIDE

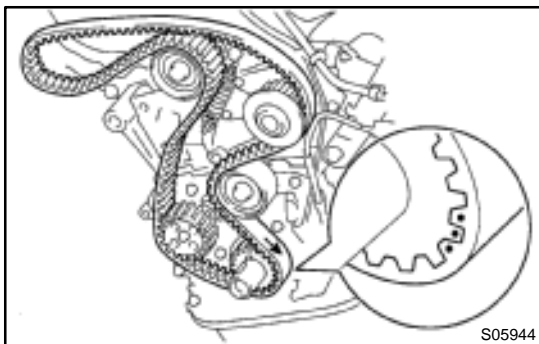

16. REMOVE TIMING BELT

HINT:

When re-using timing belt:

Draw a direction arrow on the timing belt (in the direction of engine revolution), and place matchmarks on the timing belt and crankshaft timing pulley.

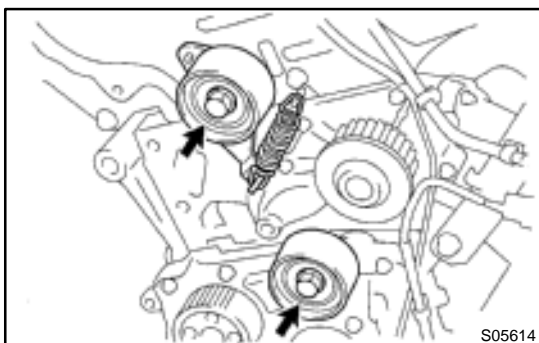

17. REMOVE NO.1 IDLER PULLEY AND TENSION SPRING

Remove the bolt, pulley and tension spring.

18. REMOVE NO.2 IDLER PULLEY

Remove the bolt and pulley.

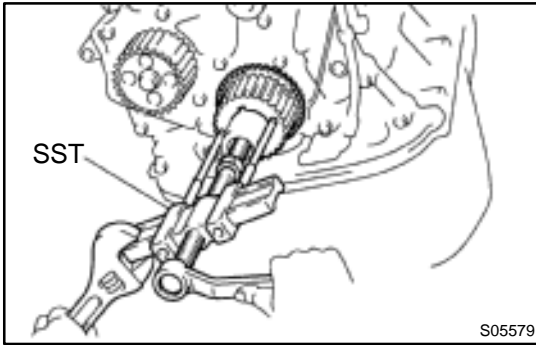
**19. REMOVE CRANKSHAFT TIMING PULLEY**

If the pulley cannot be removed by hand, use SST to remove the timing pulley.

SST 09950-50012 (09951-05010, 09952-05010, 09953-05010, 09953-05020, 09954-05010)

NOTICE:

Do not scratch the angle sensor of the timing pulley.

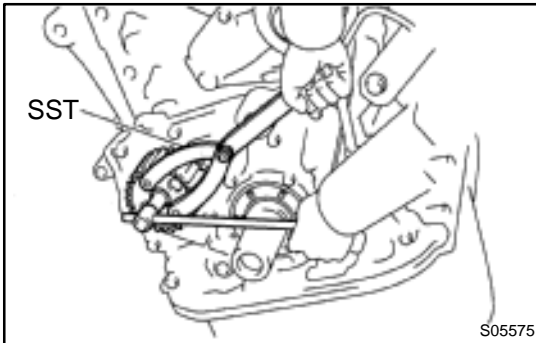
**20. REMOVE OIL PUMP PULLEY**

(a) Using SST, loosen the pulley nut.

SST 09960-10010 (09962-01000, 09963-00500)

(b) Remove the nut and pulley.

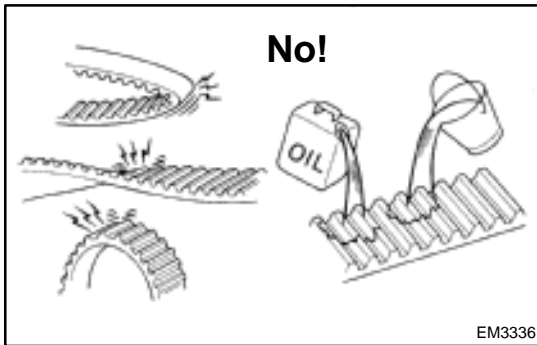

INSPECTION

1. INSPECT TIMING BELT

NOTICE:

Do not bend, twist or turn the timing belt inside out. Do not allow the timing belt to come into contact with oil, water or steam.

Do not utilize timing belt tension when installing or removing the mounting bolt of the camshaft timing pulley.

If there are any defects as shown in the illustration, check these points:

- (a) Premature parting
 - Check for proper installation.
 - Check the timing cover gasket for damage and proper installation.
- (b) If the belt teeth are cracked or damaged, check to see if either camshaft or water pump is locked.
- (c) If there is noticeable wear or cracks on the belt face, check to see if there are nicks on the side of the idler pulley lock.
- (d) If there is wear or damage on only one side of the belt, check the belt guide and the alignment of each pulley.
- (e) If there is noticeable wear on the belt teeth, check the timing cover for damage and check gasket has been installed correctly and for foreign material on the pulley teeth.

If necessary, replace the timing belt.

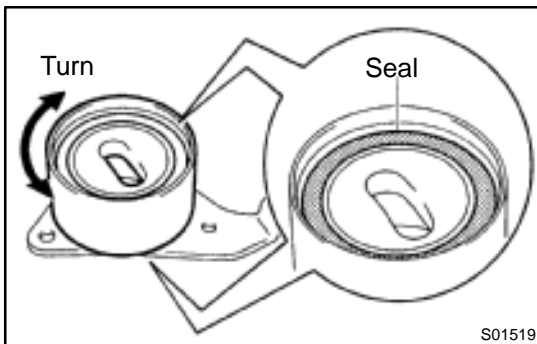

2. INSPECT IDLER PULLEYS

- (a) Visually check the seal portion of the idler pulley for oil leakage.

If leakage is found, replace the idler pulley.

- (b) Check that the idler pulley turns smoothly.
- If necessary, replace the idler pulley.

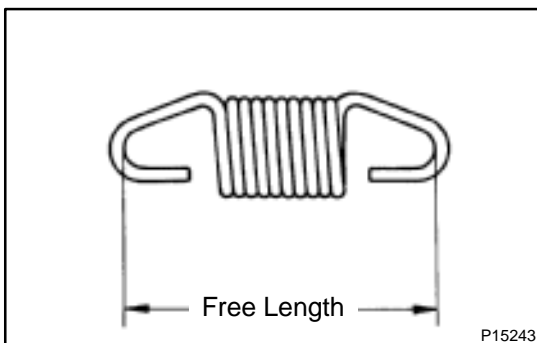

3. INSPECT TENSION SPRING

- (a) Measure the free length of tension spring.

Free length: 42.0 mm (1.654 in.)

If the free length is not as specified, replace the tension spring.

- (b) Measure the tension of the tension spring at the specified installed length.

Installed tension (at 50.5 mm (1.988 in.):

32 – 37 N (3.25 – 3.75 kgf, 7.2 – 8.3 lbf)

If the installed tension is not as specified, replace the tension spring.

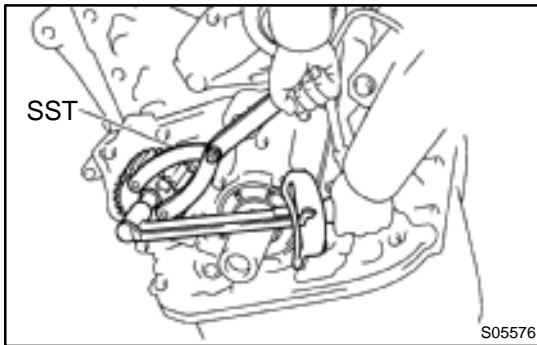

INSTALLATION

1. INSTALL OIL PUMP PULLEY

- Align the cutouts of the pulley and shaft, and slide on the pulley.
- Using SST, install the pulley nut.
SST 09960-10010 (09962-01000, 09963-00500)
Torque: 24 N·m (245 kgf-cm, 18 ft-lbf)

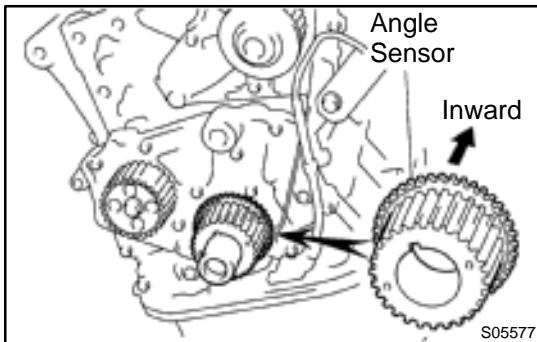

2. INSTALL CRANKSHAFT TIMING PULLEY

- Align the timing pulley set key with the key groove of the pulley.
- Slide on the timing pulley, facing the angle sensor inward.

NOTICE:

Do not scratch the angle sensor of the timing pulley.

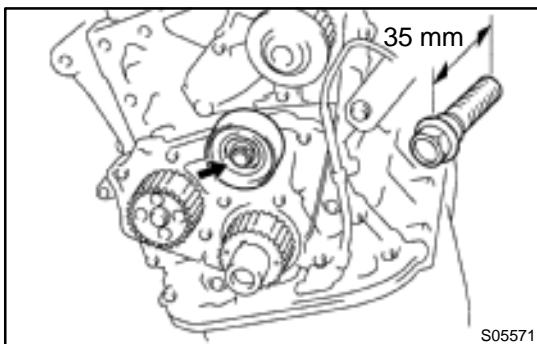

3. INSTALL NO.2 IDLER PULLEY

- Install the pulley with the bolt.
Torque: 42 N·m (425 kgf-cm, 31 ft-lbf)

HINT:

Use the 35 mm (1.38 in.) long bolt.

- Check that the idler pulley moves smoothly.

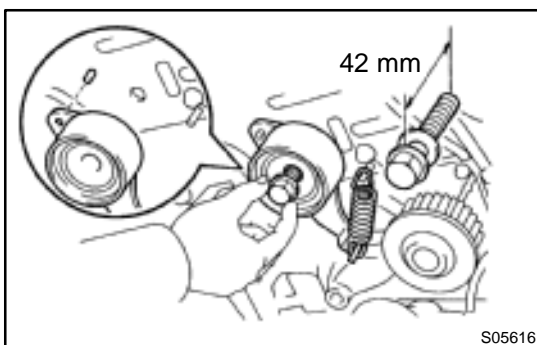

4. TEMPORARILY INSTALL NO.1 IDLER PULLEY AND TENSION SPRING

- Align the bracket pin hole with the pivot pin.
- Install the pulley with the bolt. Do not tighten the bolt yet.

HINT:

Use the 42 mm (1.65 in.) long bolt.

- Install the tension spring.

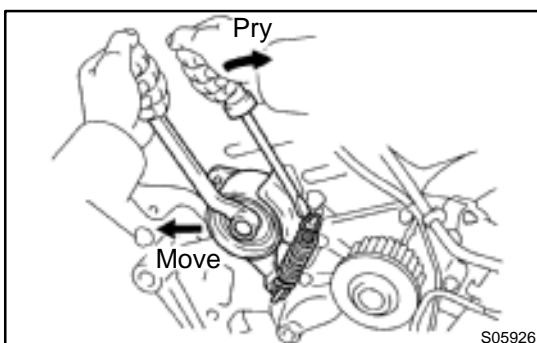

- Pry the pulley toward the left as far as it will go, and tighten the bolt.
- Check that the idler pulley moves smoothly.

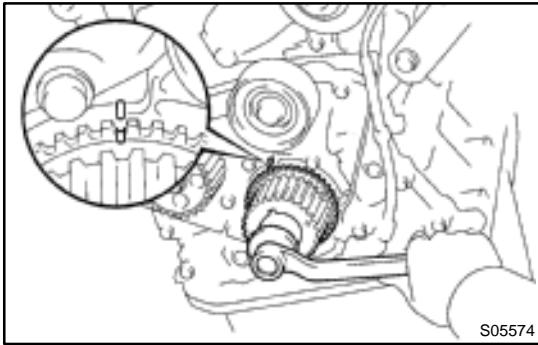

5. TEMPORARILY INSTALL TIMING BELT

NOTICE:

The engine should be cold.

- (a) Using the crankshaft pulley bolt, turn the crankshaft and align the timing marks of the crankshaft timing pulley and oil pump body.

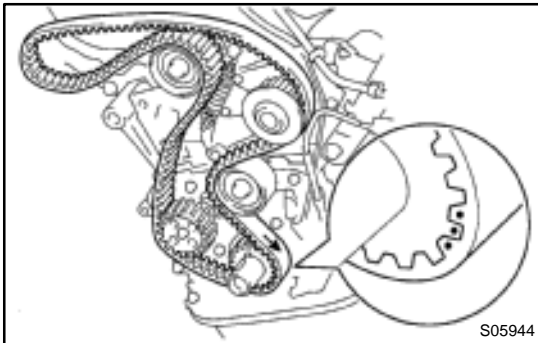

- (b) Remove any oil or water on the crankshaft pulley, oil pump pulley, water pump pulley, No.1 idler pulley and No.2 idler pulley, and keep them clean.
- (c) Install the timing belt on the crankshaft timing pulley, oil pump pulley, No.1 idler pulley, water pump pulley and No.2 idler pulley.

HINT:

When re-using timing belt:

Align the points marked during removal, and install the belt with the arrow pointing in the direction of engine revolution.

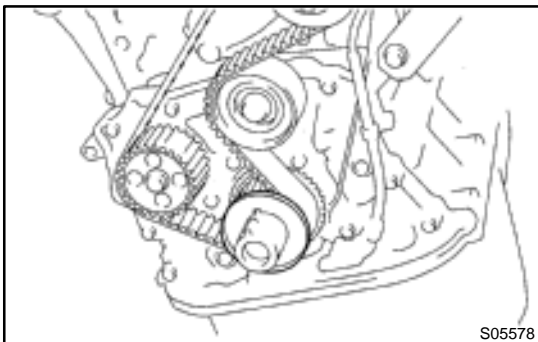

6. INSTALL TIMING BELT GUIDE

Install the guide, facing the cup side outward.

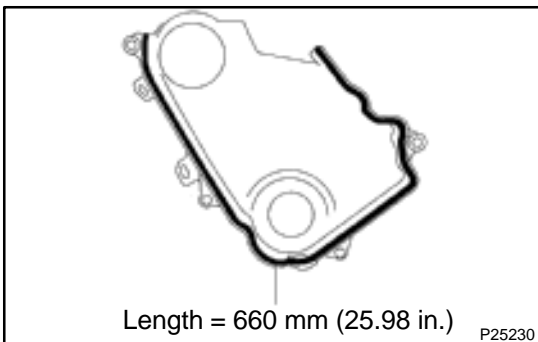

7. INSTALL NO.1 TIMING BELT COVER

- (a) Check that the timing belt cover gasket has no cracks or peeling, etc.

If the gasket has cracks or peeling, etc., replace it using these steps:

- (1) Using a screwdriver and gasket scraper, remove all the old gasket material.
- (2) Thoroughly clean all components to remove all the loose material.
- (3) Remove the backing paper from a new gasket and install the gasket evenly to the part of the timing belt cover shaded black in the illustration.
- (4) After installing the gasket, press down on it so that the adhesive firmly sticks to the timing belt cover.

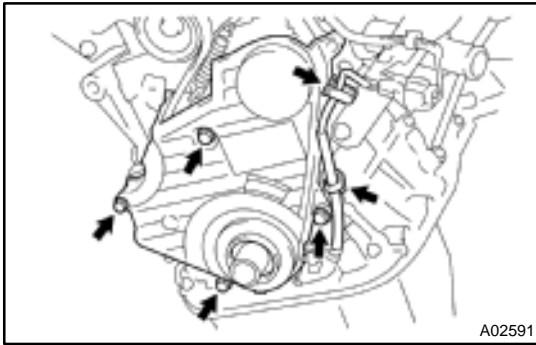

- (b) Install the timing belt cover with the 4 bolts.
- (c) Install the clamp of the crankshaft position sensor wire to the timing belt cover.
- (d) Install the crankshaft position sensor wire to the clamp on the timing belt cover.

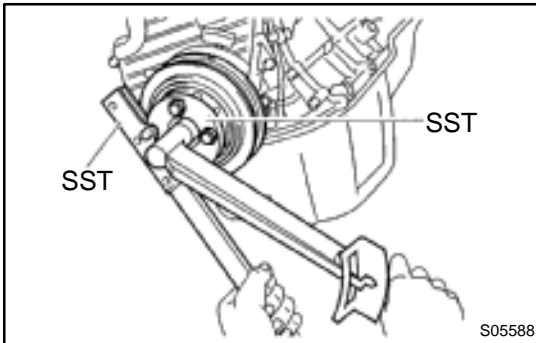

8. INSTALL CRANKSHAFT PULLEY

- (a) Align the pulley set key with the key groove of the pulley, and slide on the pulley.
- (b) Using SST (and bolt), install the pulley bolt.
SST 09213-54015 (91651-60855), 09330-00021
Torque: 108 N·m (1,100 kgf·cm, 80 ft·lbf)

HINT:

Either of 2 types of pulley may be used, each with its own bolt size, type A (91651-60855) and type B (part No. 91121-40665).

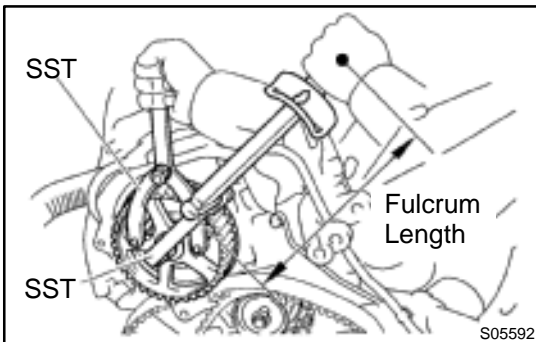

9. INSTALL CAMSHAFT TIMING PULLEY

- (a) Align the camshaft knock pin with the knock pin groove of the pulley, and slide on the timing pulley.
- (b) Using SST, install the pulley bolt.
SST 09249-63010, 09960-10010 (09962-01000, 09963-01000)

Torque:

54 N·m (550 kgf·cm, 40 ft·lbf)

37 N·m (380 kgf·cm, 27 ft·lbf) for use with SST

HINT:

Use a torque wrench with a fulcrum length of 340 mm (13.39 in.).

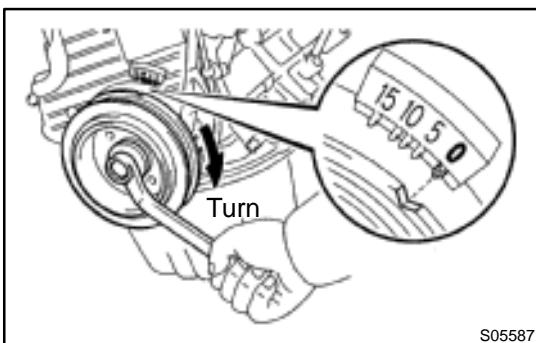

10. SET NO.1 CYLINDER TO TDC/COMPRESSION

- (a) Turn the crankshaft pulley, and align its groove with timing mark "0" of the No.1 timing belt cover.

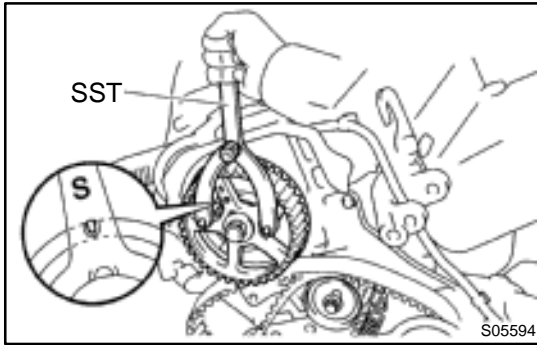

- (b) Using SST, turn the camshaft, and align the hole of the camshaft timing pulley with the timing mark of the bearing cap.
SST 09960-10010 (09962-01000, 09963-01000)

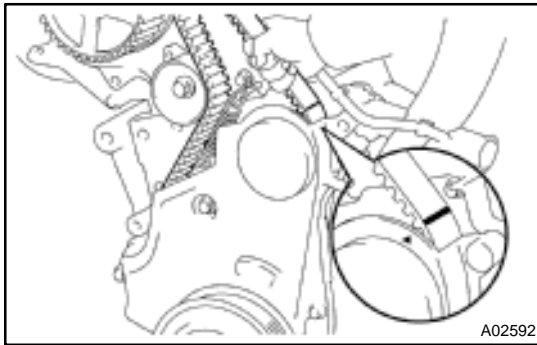

11. CONNECT TIMING BELT TO CAMSHAFT TIMING PULLEY

HINT:

When re-using timing belt:

Check that the matching marks of the timing belt and the No.1 timing belt cover meet.

If the matchmark does not align, shift the meshing of the timing belt and crankshaft timing pulley until they align.

(See page EM-17)

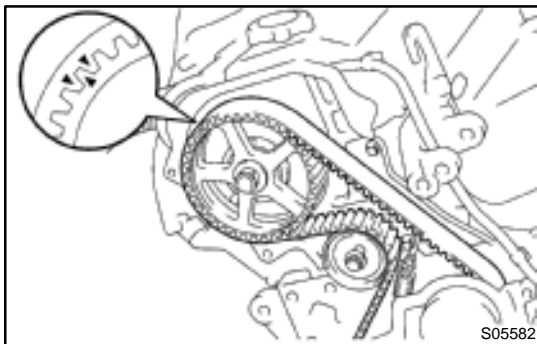

When re-using timing belt:

Align the matchmarks of the timing belt and camshaft timing pulley.



- (a) Remove any oil or water on the camshaft timing pulley, and keep it clean.
(b) Connect the timing belt to the camshaft timing pulley, and checking the tension between the crankshaft timing pulley and camshaft timing pulley.

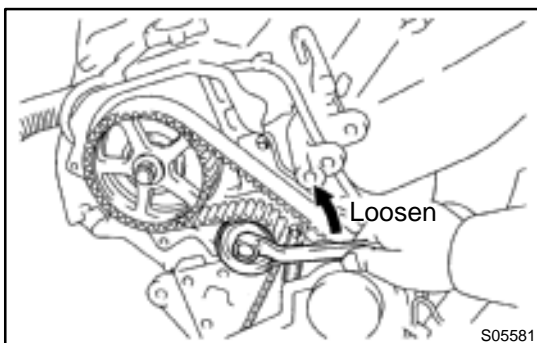

12. CHECK VALVE TIMING

- (a) Loosen the No.1 idler pulley bolt 1/2 turn.

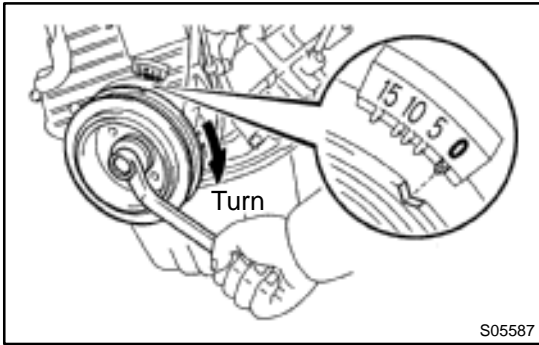

(b) Slowly turn the crankshaft pulley 2 revolutions TDC to TDC.

NOTICE:
Always turn the crankshaft pulley clockwise.

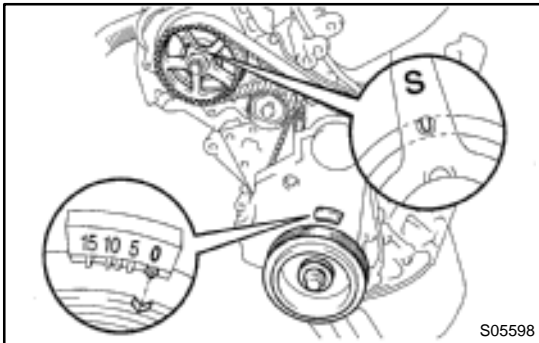

(c) Check that each pulley aligns with the timing marks as shown in the illustration.

If the timing marks do not align, remove the timing belt and reinstall it.

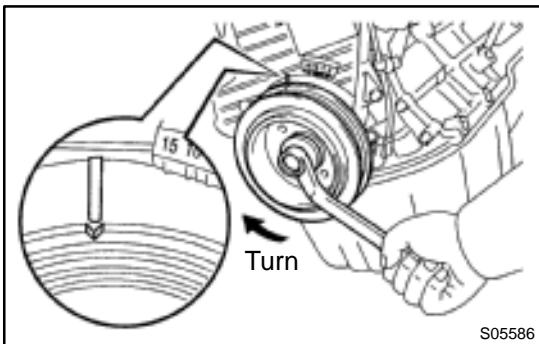

(d) Slowly turn the crankshaft pulley 1 and 7/8 revolutions, and align its groove with the mark at 45° BTDC (for No.1 cylinder) of the No.1 timing belt cover.

NOTICE:
Always turn the crankshaft pulley clockwise.

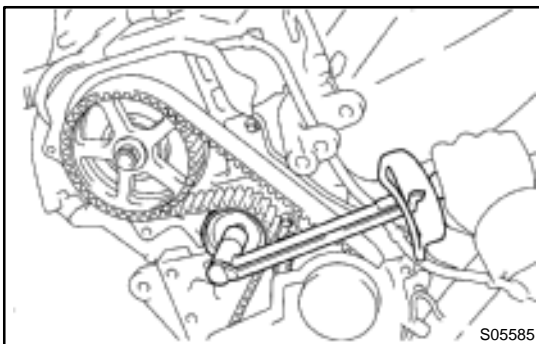

(e) Tighten the mounting bolt of the No.1 idler pulley.
Torque: 42 N·m (425 kgf·cm, 31 ft·lbf)

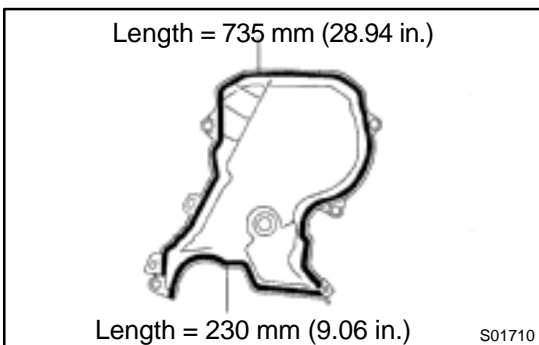

13. INSTALL NO.2 TIMING BELT COVER

(a) Check that the timing belt cover gaskets have no cracks or peeling, etc.

If the gasket has cracks or peeling, etc., replace it using these steps:

- (1) Using a screwdriver and gasket scraper, remove all the old gasket material.
- (2) Thoroughly clean all components to remove all the loose material.

- (3) Remove the backing paper from a new gasket and install the gasket evenly to the part of the timing belt cover shaded black in the illustration.
- (4) After installing the gasket, press down on it so that the adhesive firmly sticks to the timing belt cover.

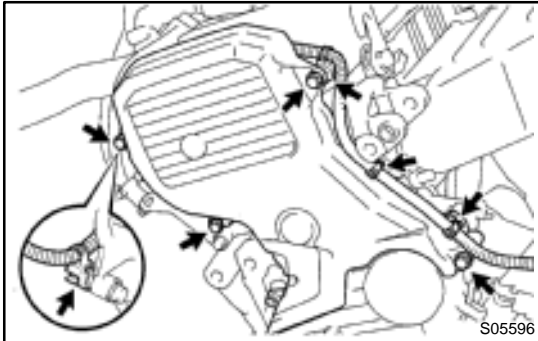

- (b) Install the belt cover with the 4 bolts.
- (c) Install the engine wire clamp.

14. INSTALL SPARK PLUGS

- (a) Install the 4 spark plugs.
- (b) Connect the 4 high-tension cords to the spark plugs.
- (c) Install the 4 high-tension cords to the clamps on the cylinder head cover.

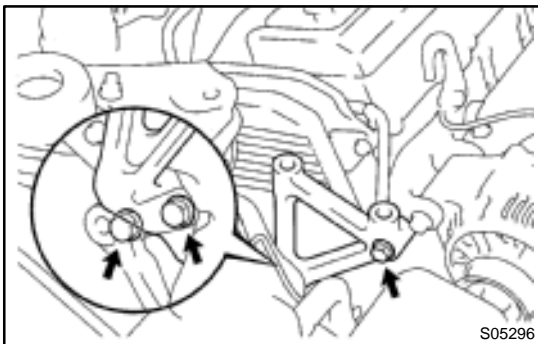

15. INSTALL NO.2 RH ENGINE MOUNTING BRACKET

- (a) Install the mounting bracket with the 3 bolts.
- (b) Alternately tighten the 3 bolts in several passes.
Torque: 52 N·m (530 kgf-cm, 38 ft-lbf)

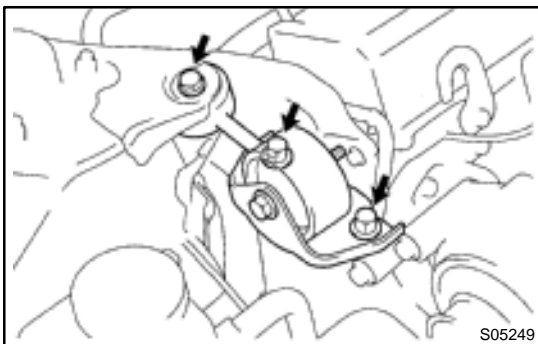

16. INSTALL ENGINE MOVING CONTROL ROD

- (a) Temporarily install the control rod with the 3 bolt.
- (b) Alternately tighten the 3 bolts in several passes.
Torque: 64 N·m (650 kgf-cm, 47 ft-lbf)

17. CONNECT GROUND STRAP CONNECTOR

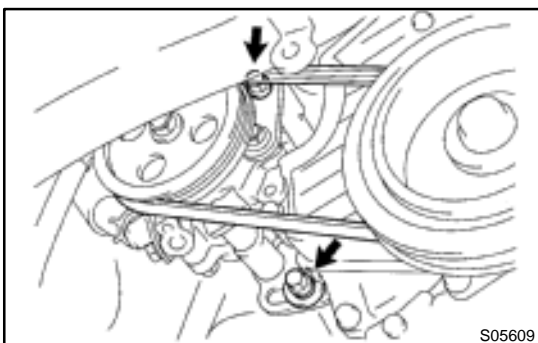

18. INSTALL PS PUMP DRIVE BELT

Install the drive belt with the 2 bolts.

19. INSTALL RH FRONT FENDER APRON SEAL

20. INSTALL RH FRONT WHEEL

21. INSTALL GENERATOR (See page CH-16)



EM087-03

COMPONENTS

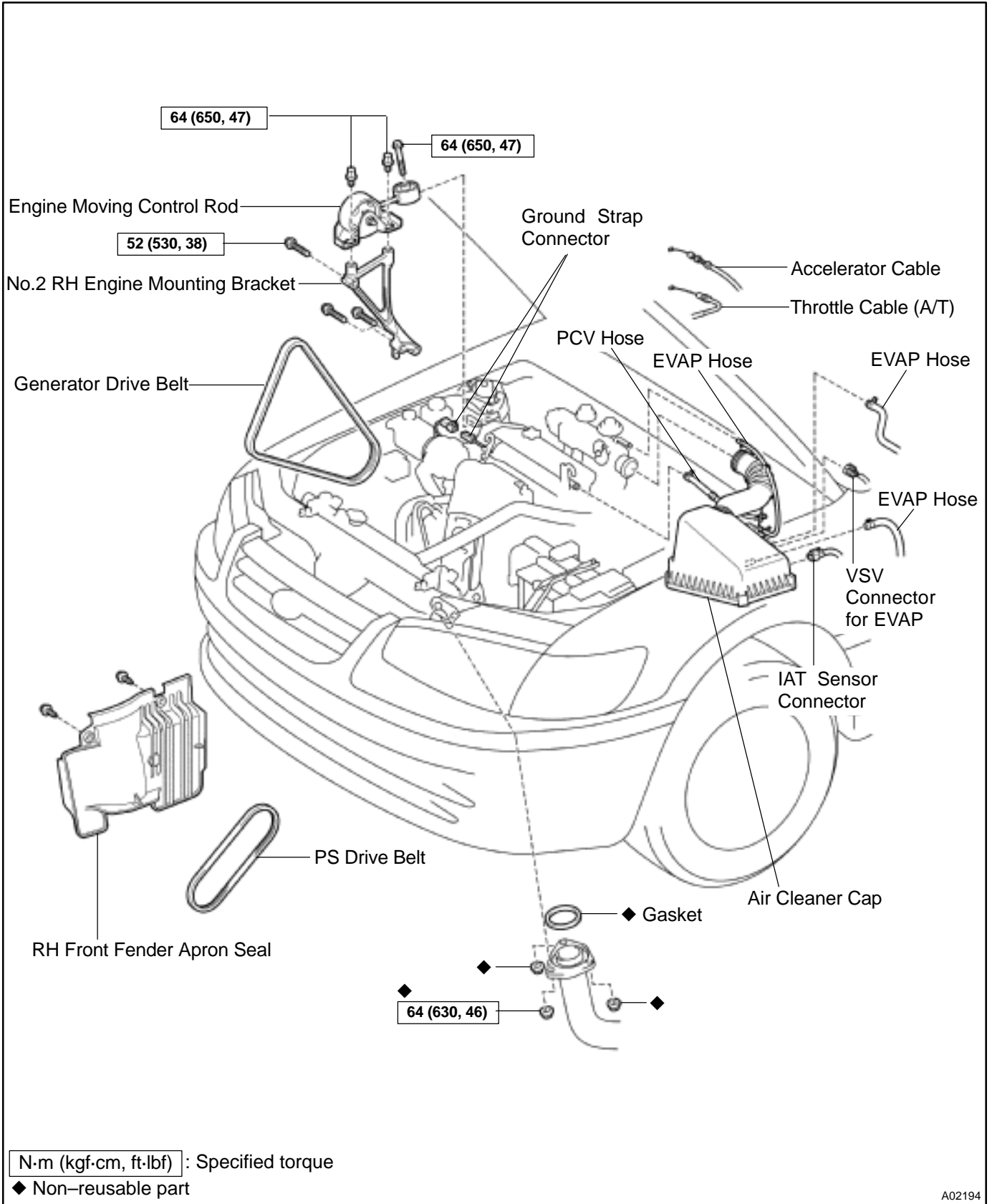

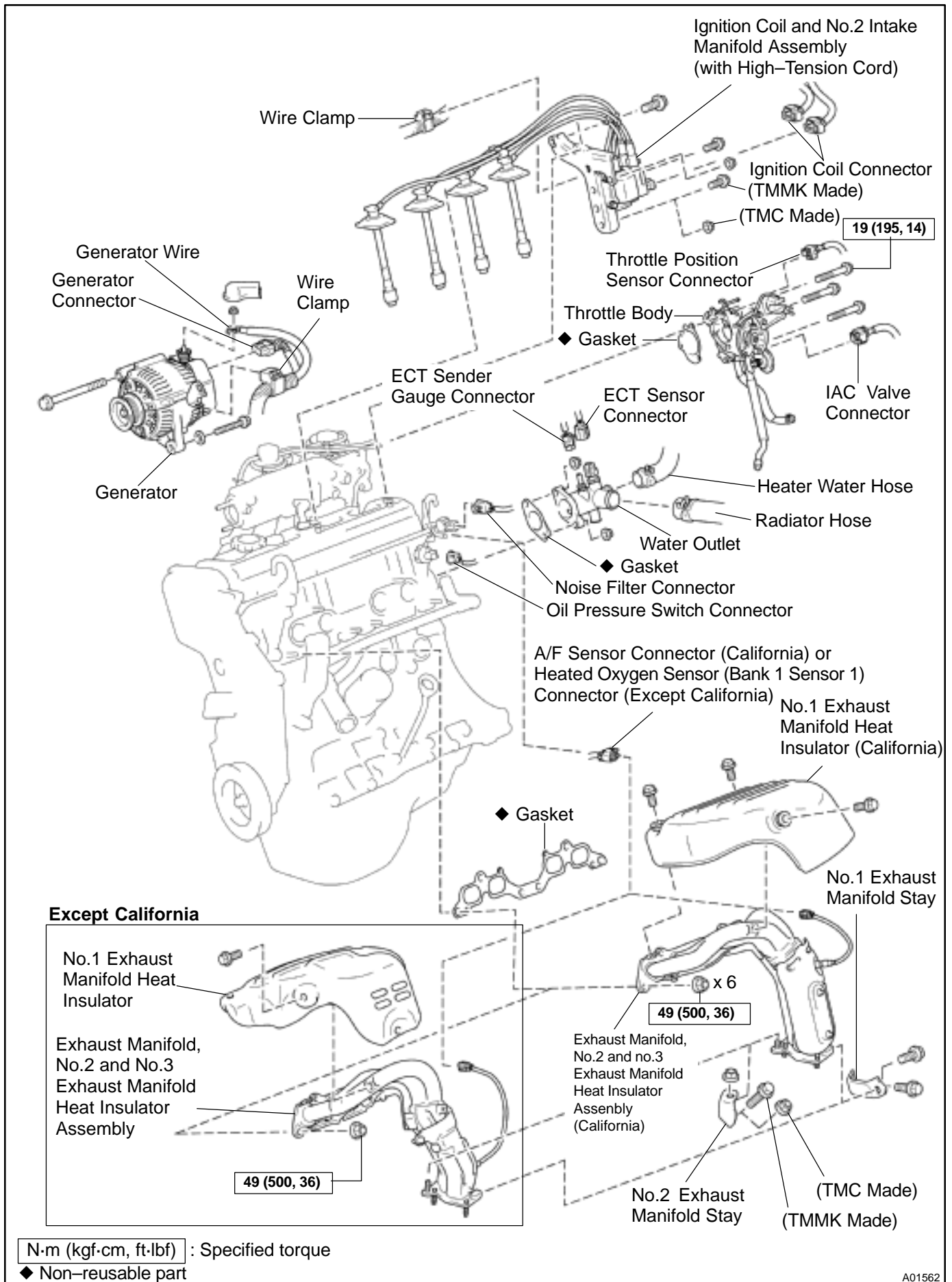

A01562

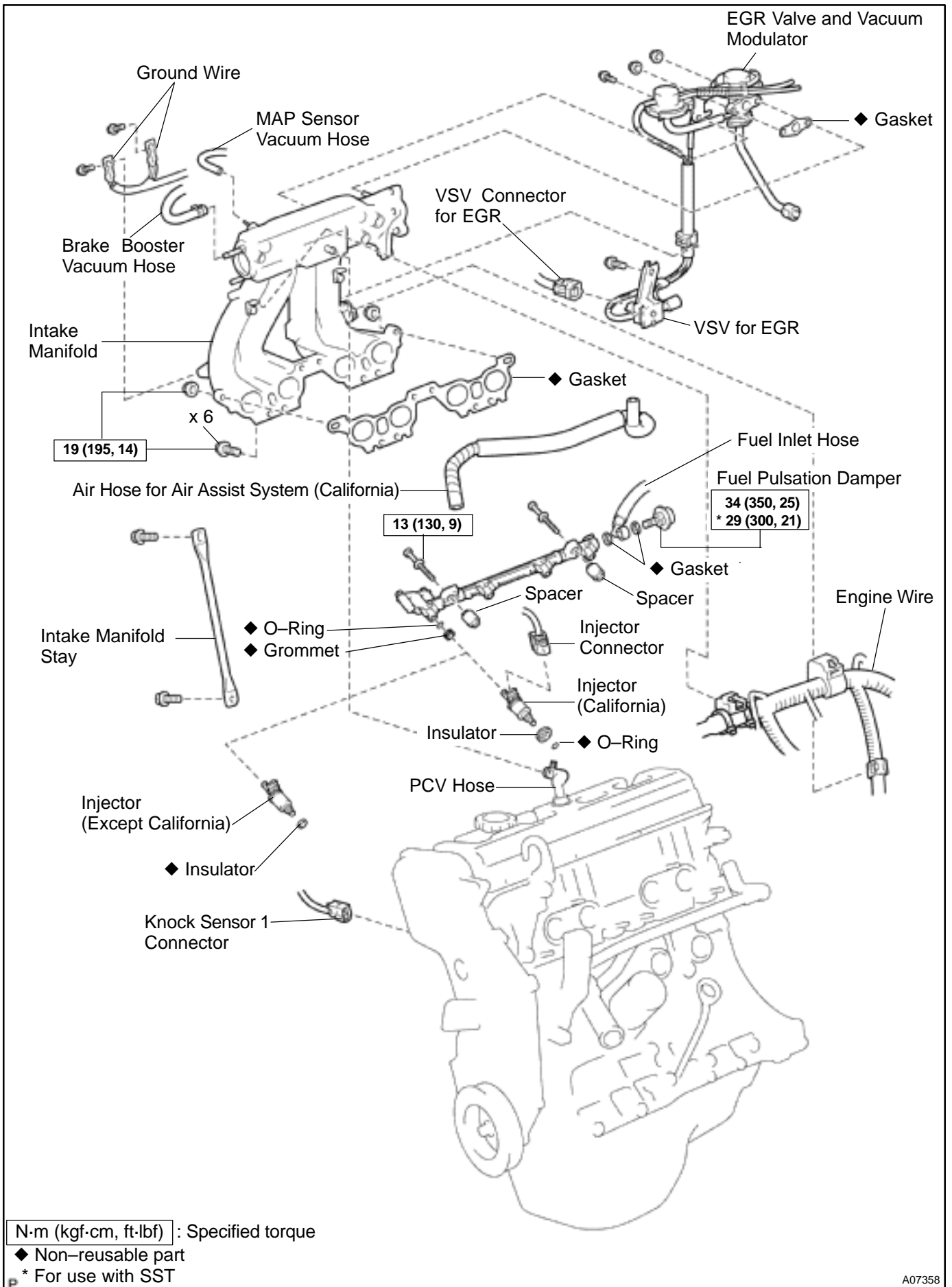

A07358

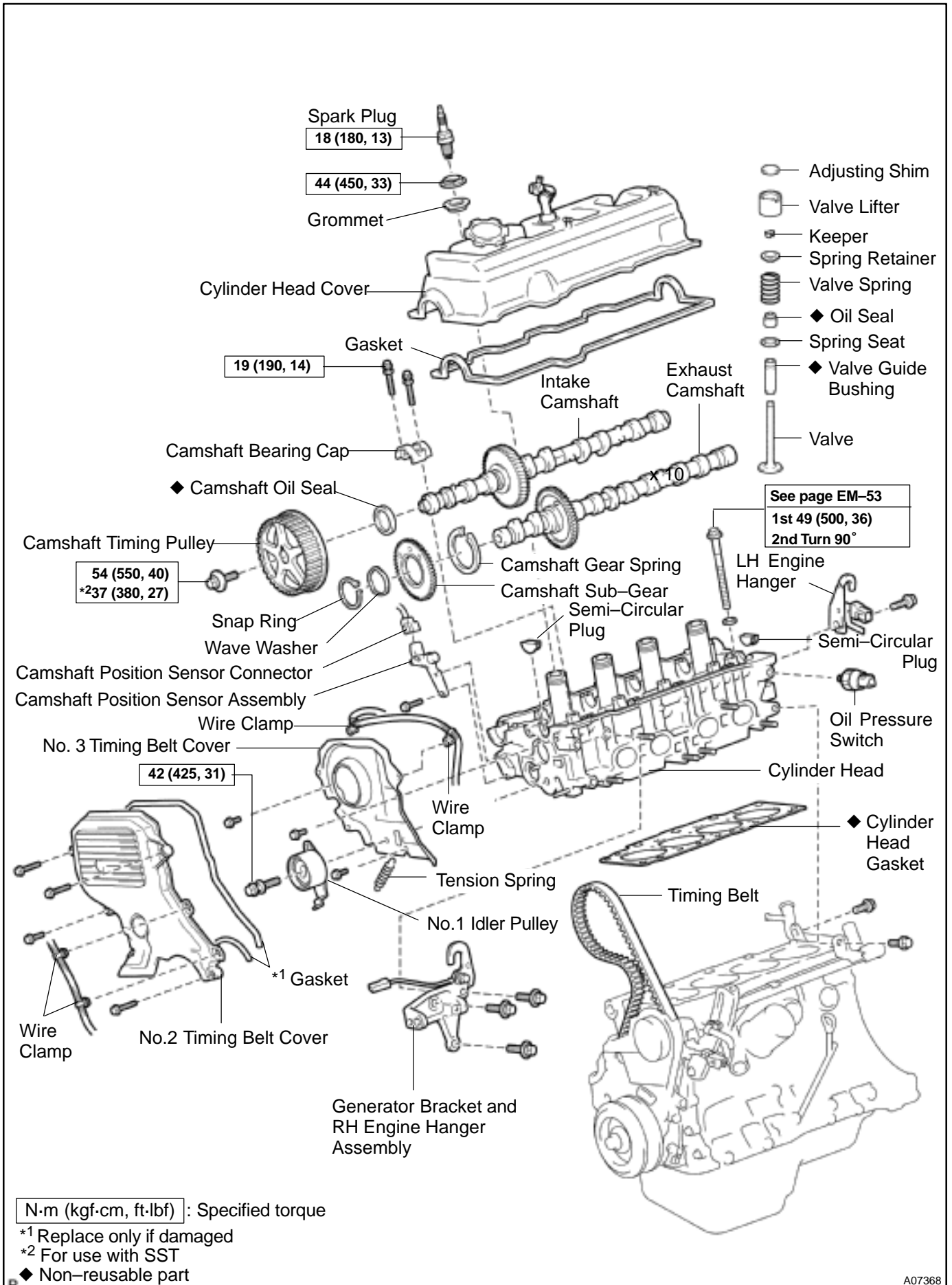

N·m (kgf·cm, ft·lbf) : Specified torque
 *1 Replace only if damaged
 *2 For use with SST
 ◆ Non-reusable part

REMOVAL

1. DRAIN ENGINE COOLANT
2. REMOVE AIR CLEANER CAP (See page EM-69)
3. REMOVE GENERATOR (See page CH-6)

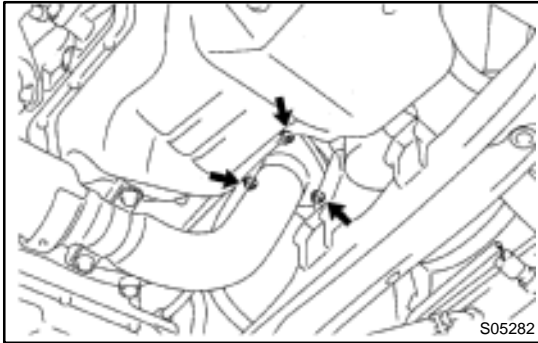

4. REMOVE EXHAUST MANIFOLD

- (a) Remove the 3 nuts holding the front exhaust pipe to the exhaust manifold.
- (b) Remove the 3 (California) or 5 (Except California) bolts and No.1 exhaust manifold heat insulator.

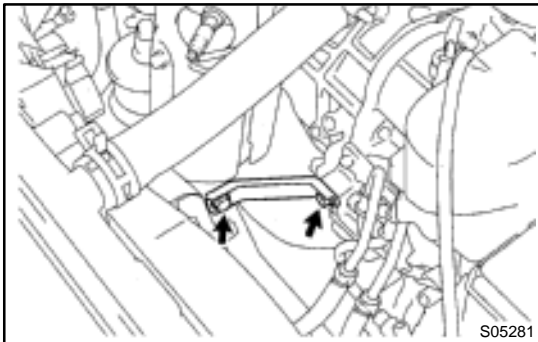

- (c) Remove the 2 bolts and No.1 exhaust manifold stay.

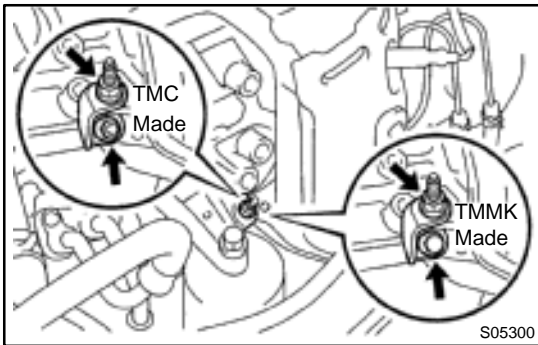

- (d) TMC Made:
Remove the 2 nuts and No.2 exhaust manifold stay.
- (e) TMMK Made:
Remove the bolt, nut and No.2 exhaust manifold stay.

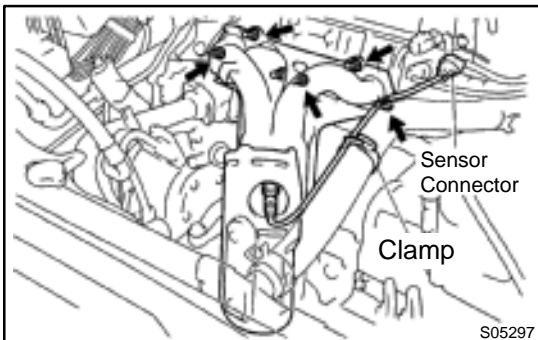

- (f) Remove the wire clamp.
- (g) California:
Disconnect the A/F sensor connector.
- (h) Except California:
Disconnect the oxygen sensor (bank 1 sensor 1) connector.
- (i) Remove the 6 nuts, the exhaust manifold, No.2 and No.3 exhaust manifold heat insulators assembly.

- (j) California:
Disconnect the A/F sensor connector for the wiring side from the bracket on the LH engine hanger.
 - (k) Except California:
Disconnect the heated oxygen sensor (bank 1 sensor 1) connector for the wiring side from the bracket on the LH engine hanger.
5. **REMOVE THROTTLE BODY (See page SF-32)**

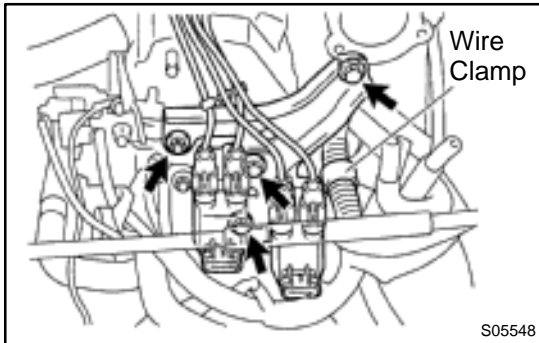

6. **REMOVE IGNITION COILS, NO.2 INTAKE MANIFOLD STAY AND HIGH-TENSION CORDS ASSEMBLY**
- (a) Disconnect the 2 ignition coil connectors.
 - (b) Disconnect the 4 high-tension cords from the 2 clamps on the cylinder head cover.
 - (c) Disconnect the 4 high-tension cords from the spark plugs.
 - (d) Disconnect the wire clamp from the manifold stay.
 - (e) TMC Made:
Remove the 2 nuts, 2 bolts, 2 ignition coils, manifold stay and 4 high-tension cords assembly.
 - (f) TMMK Made:
Remove the nut, 3 bolts, 2 ignition coils, manifold stay and 4 high-tension cords assembly.
7. **DISCONNECT OIL PRESSURE SWITCH CONNECTOR**
8. **DISCONNECT NOISE FILTER CONNECTOR**

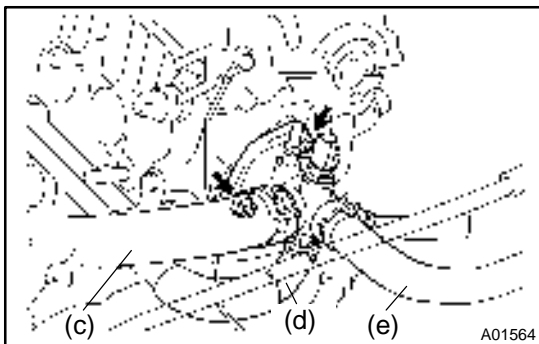

9. **REMOVE WATER OUTLET**
- (a) Disconnect the ECT sensor connector.
 - (b) Disconnect the ECT sender gauge connector.
 - (c) Disconnect the radiator hose from the water outlet.
 - (d) Disconnect the water bypass pipe hose from the water outlet.
 - (e) Disconnect the heater water hose from the water outlet.
 - (f) Remove the 2 nuts, water outlet and gasket.

10. **REMOVE INTAKE MANIFOLD STAY**

Remove the bolt, nut and intake manifold stay.

11. **REMOVE EGR VALVE AND VACUUM MODULATOR**

- (a) Disconnect the VSV connector for the EGR.
- (b) Disconnect the hose clamp from the bracket on the intake manifold.
- (c) Remove the bolt, and disconnect the VSV for EGR from the intake manifold.

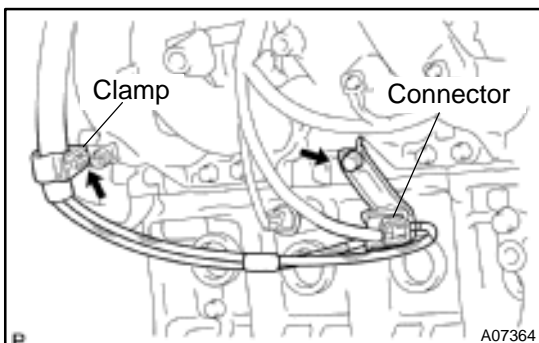

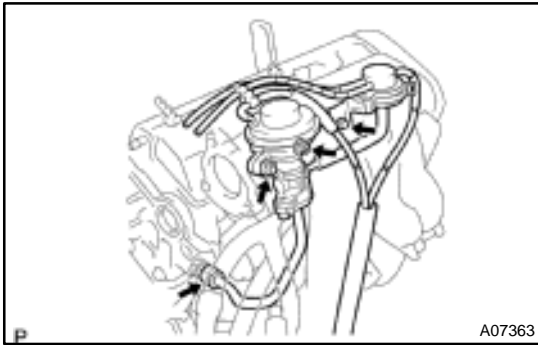

- (d) Loosen the union nut of the EGR pipe, and remove the bolt, 2 nuts, the EGR valve, vacuum modulator, vacuum hoses assembly and gasket.

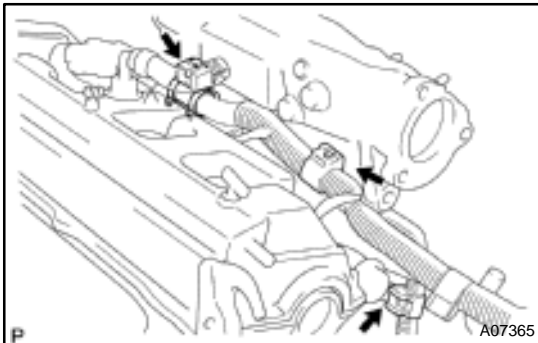

12. DISCONNECT ENGINE WIRE FROM INTAKE MANIFOLD

- (a) Disconnect the engine wire clamp from the bracket on the LH side of the intake manifold.
 (b) Disconnect the 2 engine wire clamps from the 2 brackets on the front side of the intake manifold.

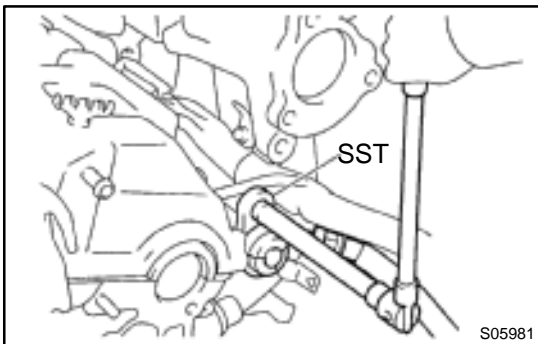

13. DISCONNECT FUEL INLET HOSE FROM DELIVERY PIPE

- (a) Using SST, loosen the fuel pulsation damper.
 SST 09612-24014 (09617-24011)
 (b) Remove the fuel pulsation damper and 2 gaskets, and disconnect the fuel inlet hose from the delivery pipe.

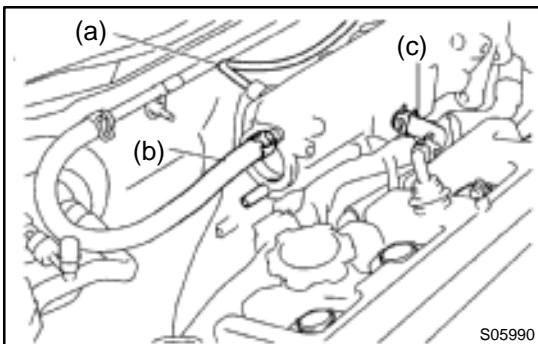

14. REMOVE INTAKE MANIFOLD

- (a) Disconnect the MAP sensor vacuum hose from the gas filter.
 (b) Disconnect the brake booster vacuum hose from the intake manifold.
 (c) Disconnect the PCV hose from the intake manifold.

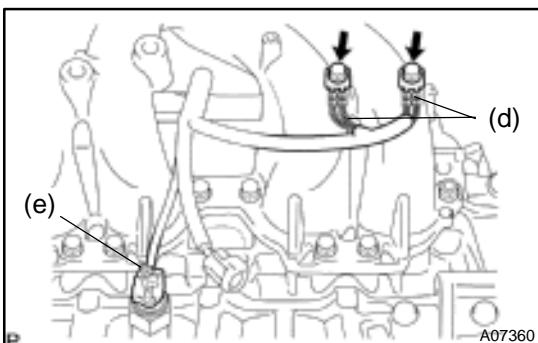

- (d) Remove the 2 bolts, and disconnect the 2 ground wires from the intake manifold.
 (e) Disconnect the knock sensor 1 connector.

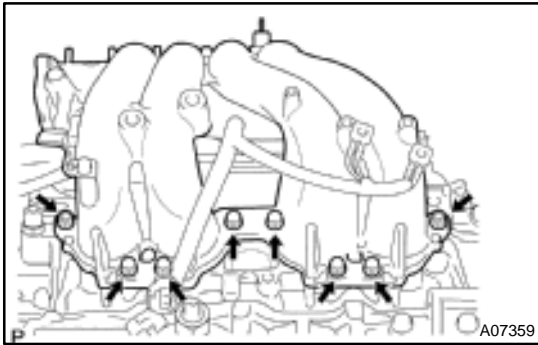

(f) Remove the 6 bolts, 2 nuts, intake manifold and gasket.

15. California:

REMOVE AIR HOSE FOR AIR ASSIST SYSTEM

Disconnect the air hose from the cylinder head port, and remove the air hose.

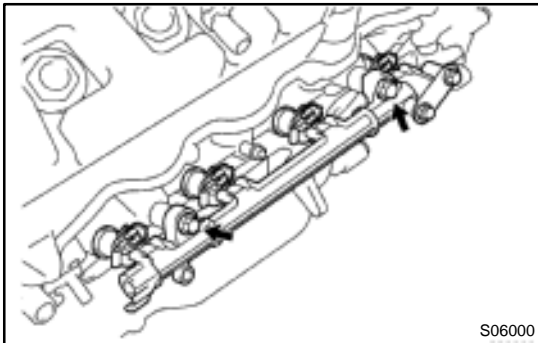

16. REMOVE DELIVERY PIPE AND INJECTORS

(a) Disconnect the 4 injector connectors.

(b) Remove the 2 bolts and delivery pipe together with the 4 injectors.

NOTICE:

Be careful not to drop the injectors when removing the delivery pipe.

(c) Remove the 4 insulators (except California) and 2 spacers from the cylinder head.

(d) Pull out the 4 injectors from the delivery pipe.

(e) California:

Remove the 2 O-rings, insulator and grommet from each injector.

(f) Except California:

Remove the O-ring and grommet from each injector.

17. DISCONNECT TIMING BELT FROM CAMSHAFT TIMING PULLEY (See page EM-17)

18. REMOVE CAMSHAFT TIMING PULLEY (See page EM-17)

19. REMOVE NO.1 IDLER PULLEY AND TENSION SPRING

Remove the bolt, pulley and tension spring.

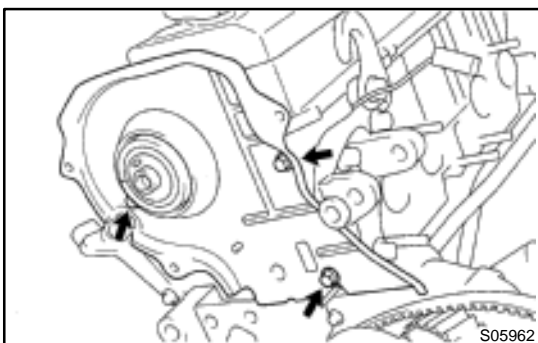

20. REMOVE NO.3 TIMING BELT COVER

Remove the 3 bolts and timing and cover.

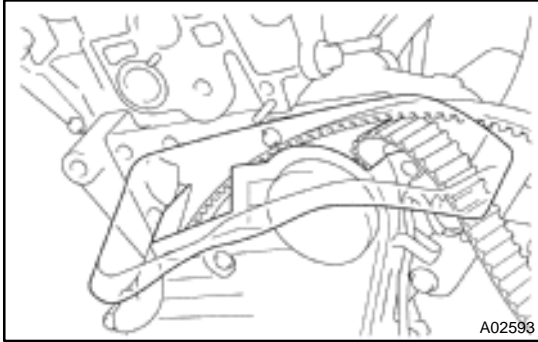
**NOTICE:**

Support the timing belt, so the meshing of the crankshaft timing pulley and timing belt does not shift.

Be careful not to drop anything inside the timing belt cover.

Do not allow the belt to come into contact with oil, water or dust.

21. REMOVE ENGINE HANGERS AND GENERATOR BRACKET

- (a) Remove the 3 bolts, the generator bracket and RH engine hanger assembly.
- (b) Remove the bolt and LH engine hanger.

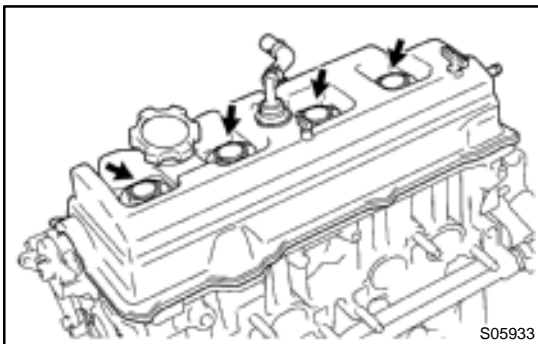
22. REMOVE OIL PRESSURE SWITCH**23. REMOVE CYLINDER HEAD COVER**

Remove the 4 nuts, grommets, head cover and gasket.

HINT:

Arrange the grommets in the correct order, so that they can be reinstalled into their original positions. This minimizes any possibility of oil leakage due to reuse of the grommets in different positions.

24. REMOVE CAMSHAFTS**NOTICE:**

Since the thrust clearance of the camshaft is small, the camshaft must be kept level while it is being removed. If the camshaft is not kept level, the portion of the cylinder head receiving the shaft thrust may crack or be damaged, causing the camshaft to seize or break. To avoid this, the following steps should be carried out.

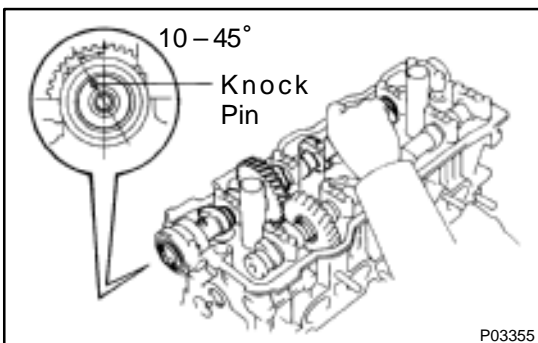

- (a) Remove the exhaust camshaft.
 - (1) Set the knock pin of the intake camshaft at 10 – 45° BTDC of camshaft angle.

HINT:

The above angle allows No.2 and No.4 cylinder cam lobes of the exhaust camshaft to push their valve lifters evenly.

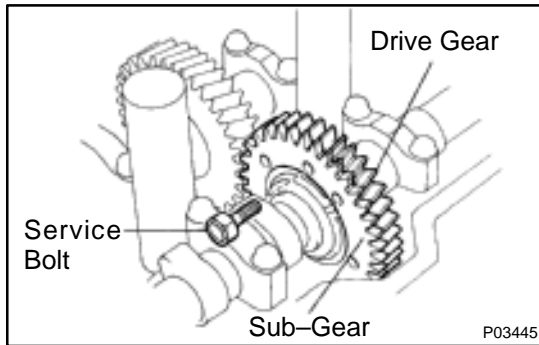

- (2) Secure the exhaust camshaft sub-gear to drive gear with a service bolt.

Recommended service bolt:

Thread diameter	6 mm
Thread pitch	1.0 mm
Bolt length	16 – 20 mm (0.63 – 0.79 in.)

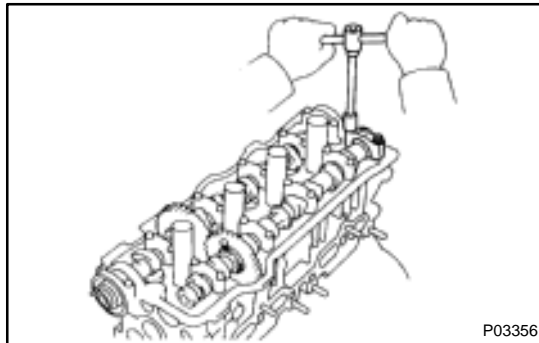

HINT:

When removing the camshaft, make sure that the torsional spring force of the sub-gear has been eliminated by the above operation.

- (3) Remove the 2 bolts and rear bearing cap.

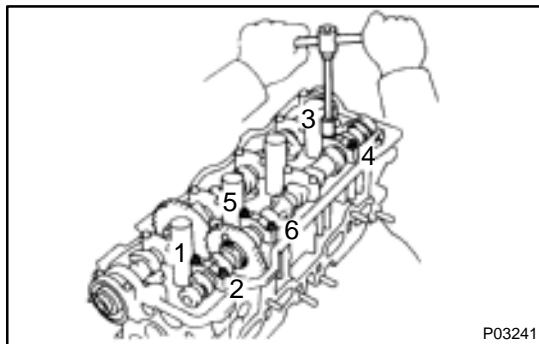

- (4) Uniformly loosen and remove the 6 bolts on the No.1, No.2 and No.4 bearing caps in several passes, in the sequence shown.

NOTICE:

Do not remove the No.3 bearing cap bolts at this stage.

- (5) Remove the No.1, No.2 and No.4 bearing caps.

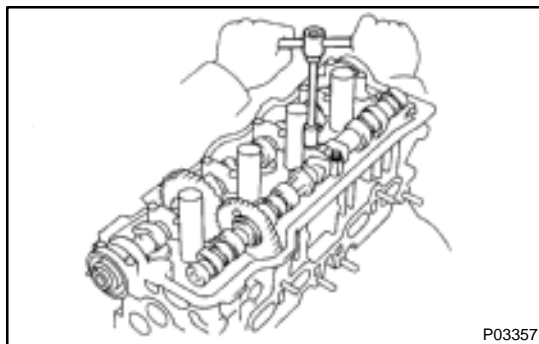

- (6) Alternately loosen and remove the 2 bolts on the No.3 bearing cap.

HINT:

As the 2 No.3 bearing cap bolts are loosened, make sure that the camshaft is lifted out straight and level.

If the camshaft is not being lifted out straight and level, retighten the 2 No.3 bearing cap bolts. Then reverse the order of above steps from (6) to (1) and reset the knock pin of the intake camshaft at 10 – 45° BTDC, and repeat steps from (2) to (6) once again.

NOTICE:

Do not pry on or attempt to force the camshaft with a tool or other object.

- (7) Remove the No.3 bearing cap and exhaust camshaft.

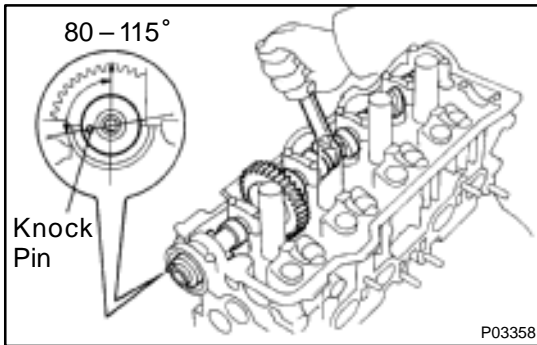

(b) Remove the intake camshaft.

- (1) Set the knock pin of the intake camshaft at 80 – 115° BTDC of camshaft angle.

HINT:

The above angle allows the No.1 and No.3 cylinder cam lobes of intake camshaft to push their valve lifters evenly.

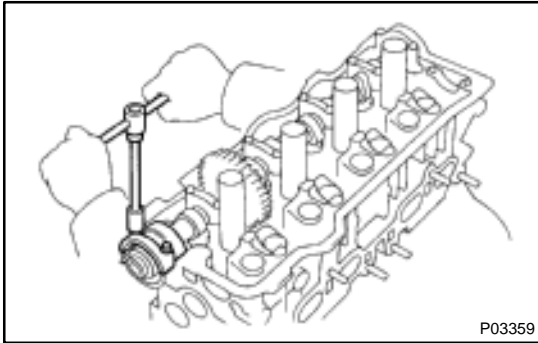

- (2) Remove the 2 bolts, front bearing cap and oil seal.

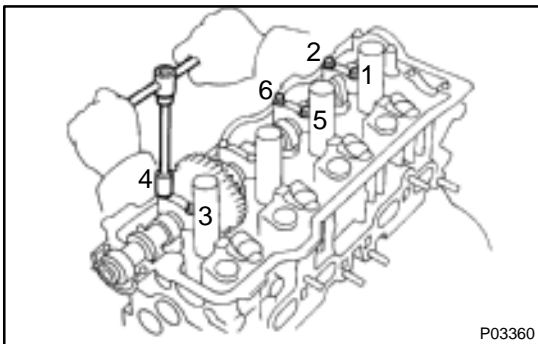

- (3) Uniformly loosen and remove the 6 bolts on the No.1, No.3 and No.4 bearing caps in several passes, in the sequence shown.

NOTICE:

Do not remove the No.2 bearing cap bolts at this stage.

- (4) Remove the No.1, No.3 and No.4 bearing caps.

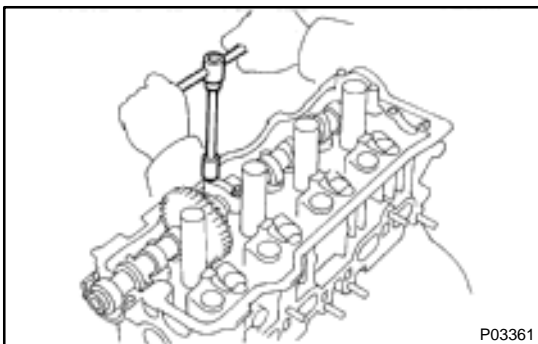

- (5) Alternately loosen and remove the 2 bolts on the No.2 bearing cap.

HINT:

As the 2 No.2 bearing cap bolts are loosened, make sure that the camshaft is lifted out straight and level, after breaking adhesion on the front bearing cap.

If the camshaft is not being lifted out straight and level, re-tighten the 2 No.2 bearing cap bolts. Reverse the order of above steps from (5) to (1) and reset the knock pin of the intake camshaft at 80 – 115° BTDC, and repeat steps from (2) to (5) once again.

NOTICE:

Do not pry on or attempt to force the camshaft with a tool or other object.

- (6) Remove the No.2 bearing cap and camshaft.

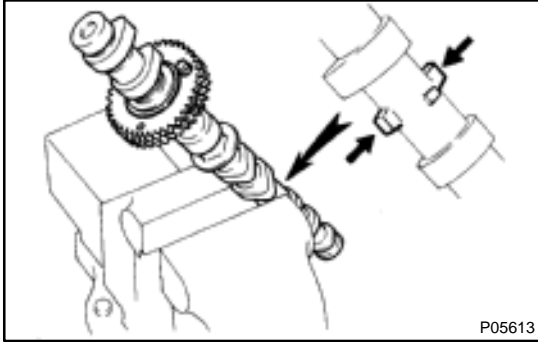

25. DISASSEMBLE EXHAUST CAMSHAFT

(a) Mount the camshaft in a vise.

NOTICE:

Be careful not to damage the camshaft.

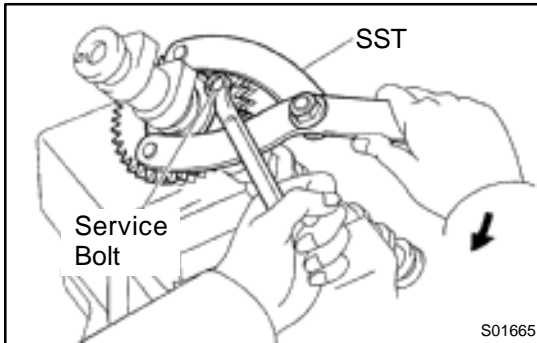

(b) Using SST, turn the sub-gear clockwise, and remove the service bolt.

SST 09960-10010 (09962-01000, 09963-00500)

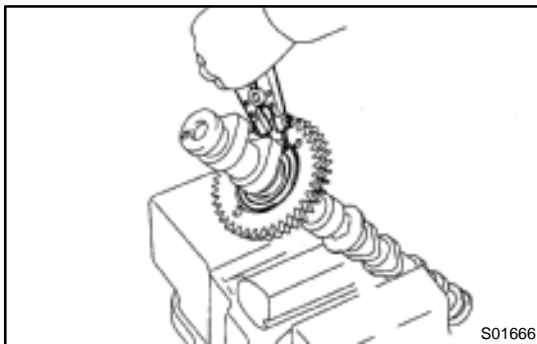

(c) Using snap ring pliers, remove the snap ring.

(d) Remove the wave washer, camshaft sub-gear and gear spring.

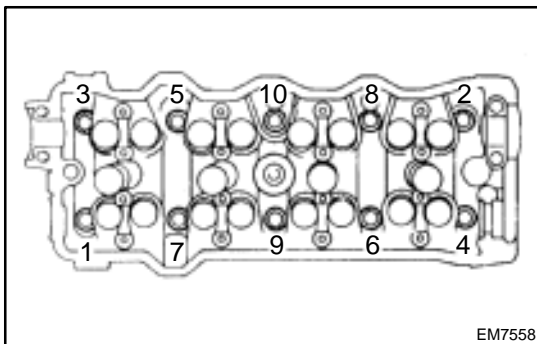

26. REMOVE CYLINDER HEAD

(a) Disconnect the camshaft position sensor connector.

(b) Remove the 2 bolts holding the water bypass pipe to the cylinder head.

(c) Uniformly loosen and remove the 10 cylinder head bolts in several passes, in the sequence shown.

NOTICE:

Cylinder head warpage or cracking could result from removing bolts in incorrect order.

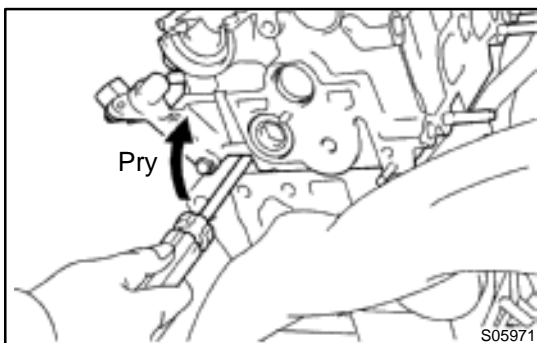

(d) Lift the cylinder head from the dowels on the cylinder block, and place the cylinder head on wooden blocks on a bench.

HINT:

If the cylinder head is off, pry between the cylinder head and cylinder block with a screwdriver.

NOTICE:

Be careful not to damage the contact surfaces of the cylinder head and cylinder block.

DISASSEMBLY

1. REMOVE CAMSHAFT POSITION SENSOR ASSEMBLY

Remove the bolt and sensor assembly.

2. REMOVE VALVE LIFTERS AND SHIMS

HINT:

Arrange the valve lifters and shims in the correct order.

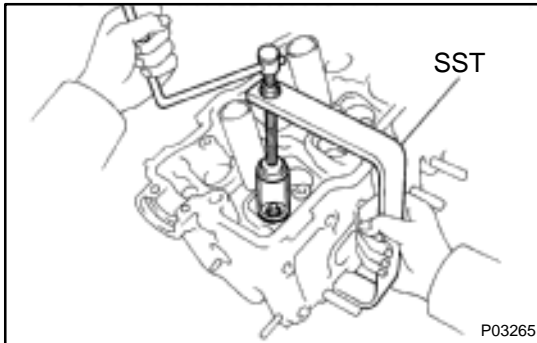

3. REMOVE VALVES

- (a) Using SST, compress the valve spring and remove the 2 keepers.

SST 09202-70020 (09202-00010)

- (b) Remove the spring retainer, valve spring, valve and spring seat.

HINT:

Arrange the valves, valve springs, spring seats and spring retainers in the correct order.

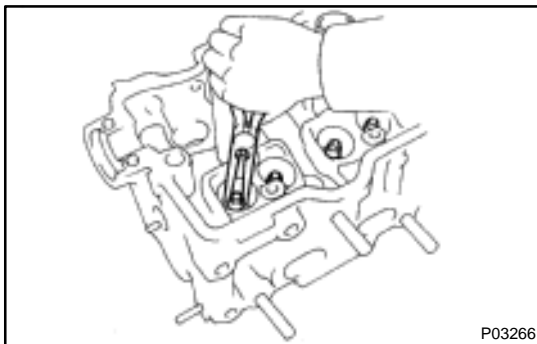

- (c) Using needle-nose pliers, remove the oil seal.

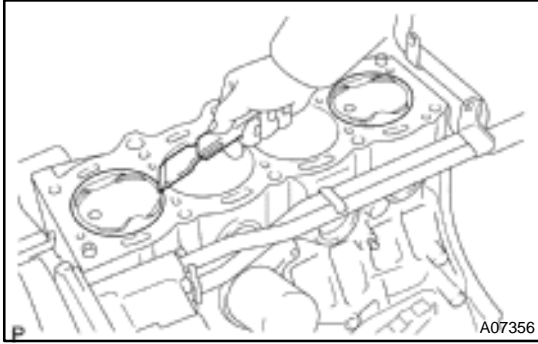

INSPECTION

1. CLEAN TOP SURFACES OF PISTONS AND CYLINDER BLOCK

- (a) Turn the crankshaft, and bring each piston to top dead center (TDC). Using a gasket scraper, remove all the carbon from the piston top surface.

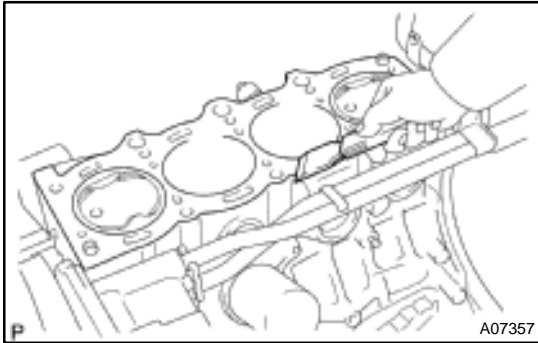

- (b) Using a gasket scraper, remove all the gasket material from the cylinder block surface.

- (c) Using compressed air, blow carbon and oil from the bolt holes.

CAUTION:

Protect your eyes when using high-pressure compressed air.

2. INSPECT TOP SURFACE OF CYLINDER BLOCK FOR FLATNESS (See page EM-97)

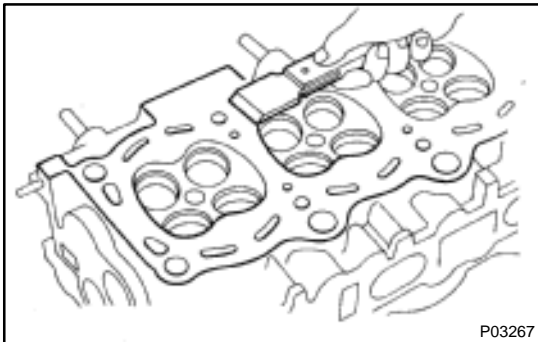

3. CLEAN CYLINDER HEAD

- (a) Using a gasket scraper, remove all the gasket material from the cylinder block contact surface.

NOTICE:

Be careful not to scratch the cylinder block contact surface.

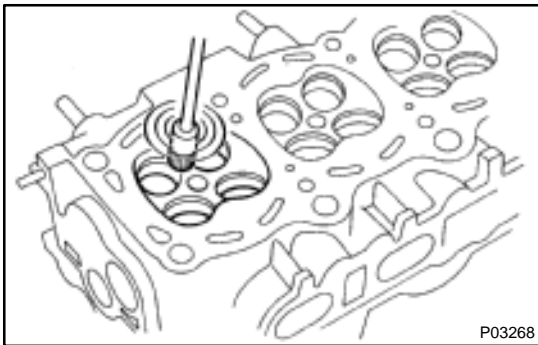

- (b) Using a wire brush, remove all the carbon from the combustion chamber.

NOTICE:

Be careful not to scratch the cylinder block contact surface.

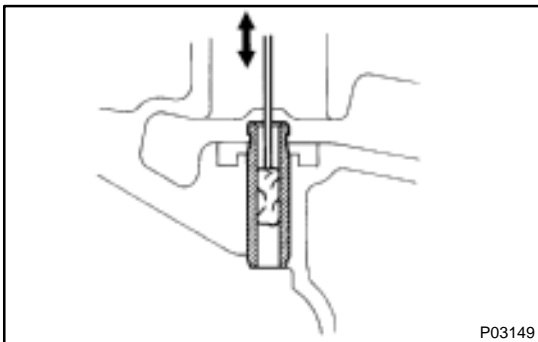

- (c) Using a valve guide bushing brush and solvent, clean all the guide bushings.

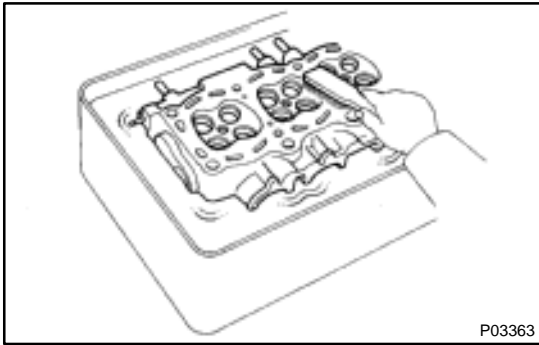

- (d) Using a soft brush and solvent, thoroughly clean the cylinder head.

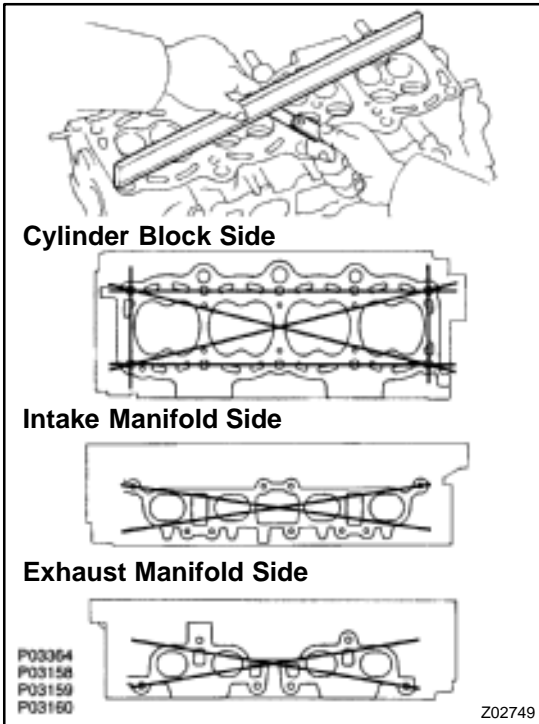

4. INSPECT CYLINDER HEAD

- (a) Inspect for flatness.
Using a precision straight edge and feeler gauge, measure the surfaces contacting the cylinder block and the manifolds for warpage.

Maximum warpage:

Cylinder block side	0.05 mm (0.0020 in.)
Manifold side	0.08 mm (0.0031 in.)

If warpage is greater than maximum, replace the cylinder head.

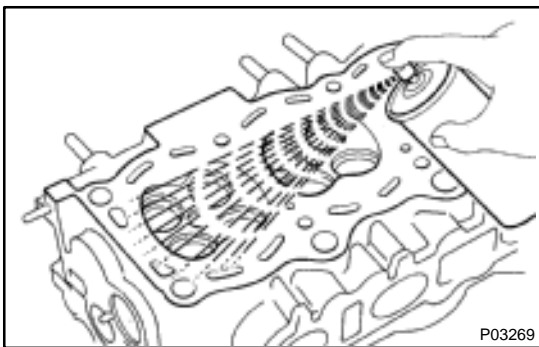

- (b) Inspect for cracks.
Using a dye penetrant, check the combustion chamber, intake ports, exhaust ports and cylinder block surface for cracks.

If cracked, replace the cylinder head.

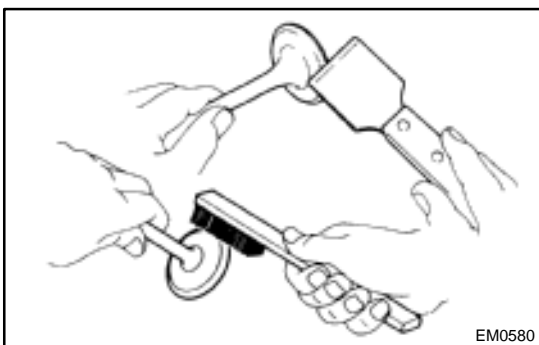

5. CLEAN VALVES

- (a) Using a gasket scraper, chip off any carbon from the valve head.
- (b) Using a wire brush, thoroughly clean the valve.

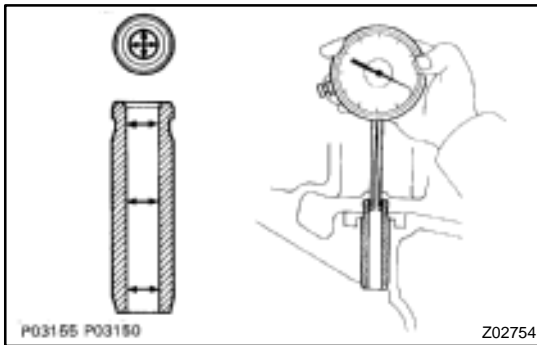
**6. INSPECT VALVE STEMS AND GUIDE BUSHINGS**

- (a) Using a caliper gauge, measure the inside diameter of the guide bushing.

Bushing inside diameter:

6.010 – 6.030 mm (0.2366 – 0.2374 in.)

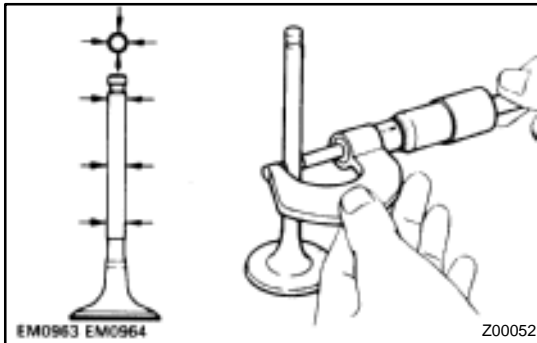

- (b) Using a micrometer, measure the diameter of the valve stem.

Valve stem diameter:

Intake	5.970 – 5.985 mm (0.2350 – 0.2356 in.)
Exhaust	5.965 – 5.980 mm (0.2348 – 0.2354 in.)

- (c) Subtract the valve stem diameter measurement from the guide bushing inside diameter measurement.

Standard oil clearance:

Intake	0.025 – 0.060 mm (0.0010 – 0.0024 in.)
Exhaust	0.030 – 0.065 mm (0.0012 – 0.0026 in.)

Maximum oil clearance:

Intake	0.08 mm (0.0031 in.)
Exhaust	0.10 mm (0.0039 in.)

If the clearance is greater than maximum, replace the valve and guide bushing. (See page EM-50)

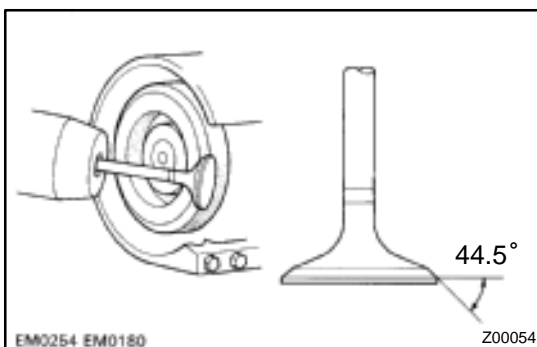
**7. INSPECT AND GRIND VALVES**

- (a) Grind the valve enough to remove pits and carbon.
 (b) Check that the valve is ground to the correct valve face angle.

Valve face angle: 44.5°

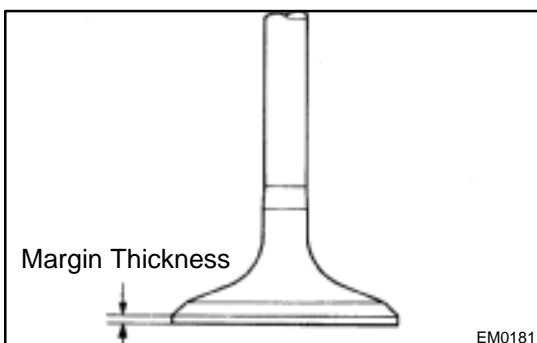

- (c) Check the valve head margin thickness.

Standard margin thickness:

0.8 – 1.2 mm (0.031 – 0.047 in.)

Minimum margin thickness: 0.5 mm (0.020 in.)

If the margin thickness is less than minimum, replace the valve.

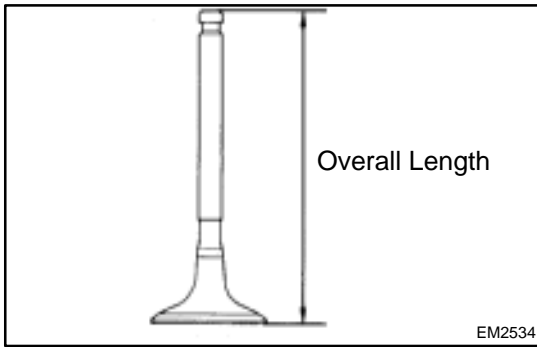

- (d) Check the valve overall length.

Standard overall length:

Intake	97.40 – 97.80 mm (3.8346 – 3.8504 in.)
Exhaust	98.25 – 98.65 mm (3.8681 – 3.8839 in.)

Minimum overall length:

Intake	97.1 mm (3.823 in.)
Exhaust	98.0 mm (3.858 in.)

If the overall length is less than minimum, replace the valve.

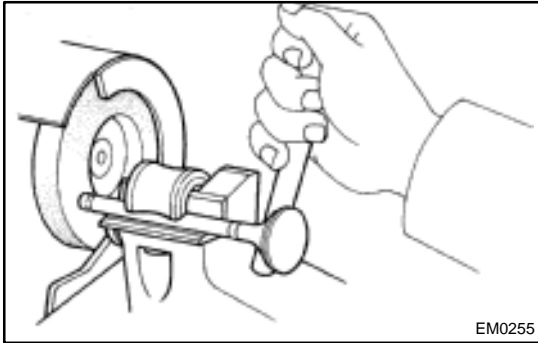

- (e) Check the surface of the valve stem tip for wear.

If the valve stem tip is worn, resurface the tip with a grinder or replace the valve.

NOTICE:

Do not grind off more than the minimum length.

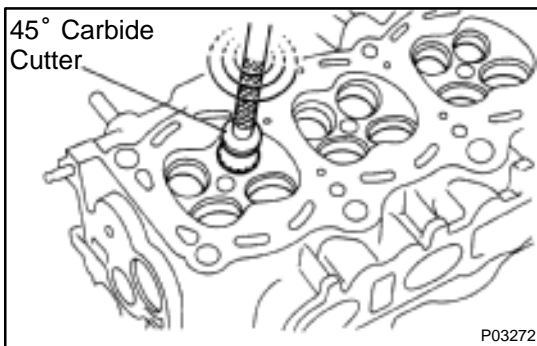
**8. INSPECT AND CLEAN VALVE SEATS**

- (a) Using a 45° carbide cutter, resurface the valve seats. Remove only enough metal to clean the seats.

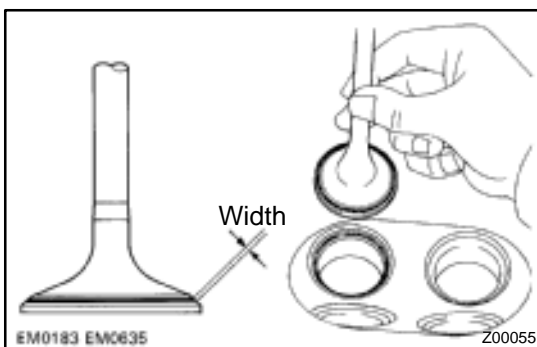

- (b) Check the valve seating position.

Apply a light coat of prussian blue (or white lead) to the valve face. Lightly press the valve against the seat. Do not rotate valve.

- (c) Check the valve face and seat for the following:

If blue appears 360° around the face, the valve is concentric. If not, replace the valve.

If blue appears 360° around the valve seat, the guide and face are concentric. If not, resurface the seat.

Check that the seat contact is in the middle of the valve face with the following width:

1.0 – 1.4 mm (0.039 – 0.055 in.)

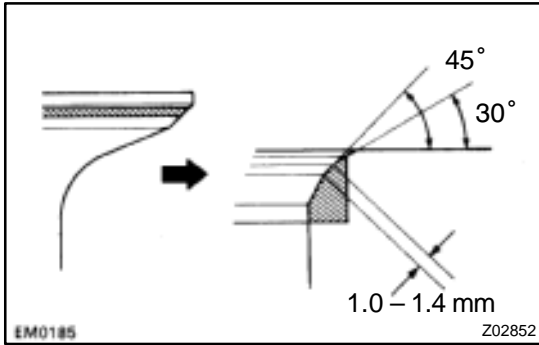

If not, correct the valve seats as follows:

- (1) If the seating is too high on the valve face, use 30° and 45° cutters to correct the seat.

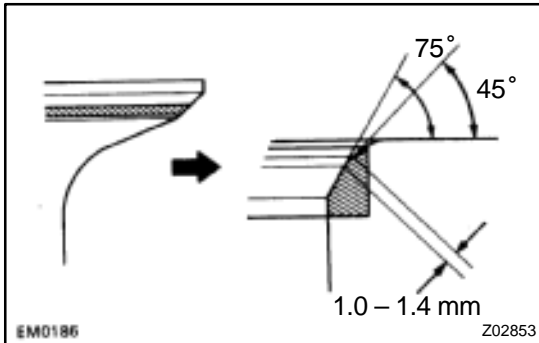

- (2) If the seating is too low on the valve face, use 75° and 45° cutters to correct the seat.

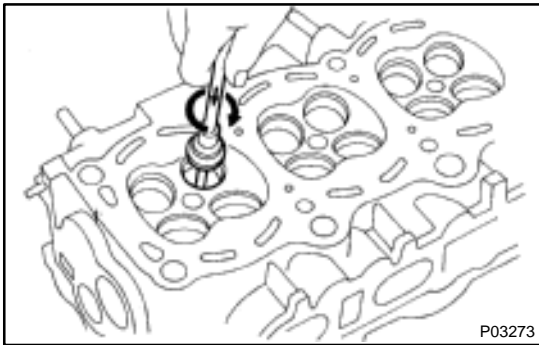

- (d) Hand-lap the valve and valve seat with an abrasive compound.
- (e) After hand-lapping, clean the valve and valve seat.

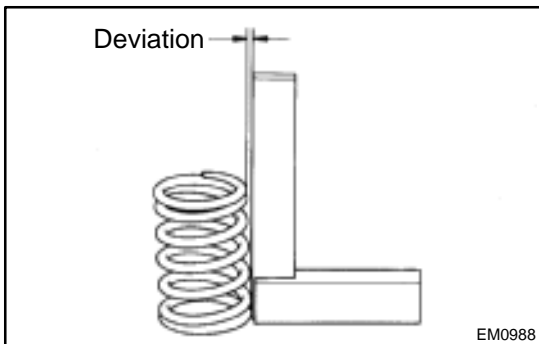

9. INSPECT VALVE SPRINGS

- (a) Using a steel square, measure the deviation of the valve spring.

Maximum deviation: 2.0 mm (0.079 in.)

If the deviation is greater than maximum, replace the valve spring.

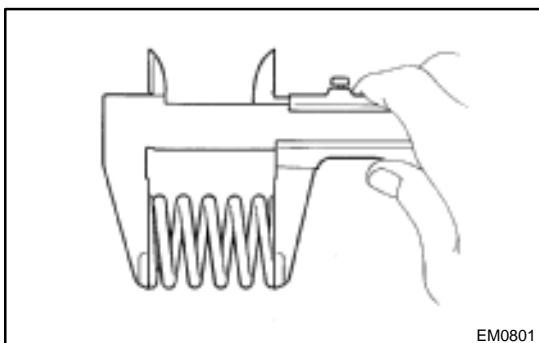

- (b) Using a vernier caliper, measure the free length of the valve spring.

Free length: 40.95 – 42.80 mm (1.6122 – 1.6850 in.)

If the free length is not as specified, replace the valve spring.

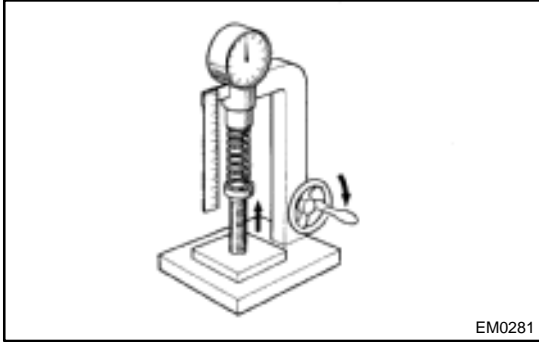

(c) Using a spring tester, measure the tension of the valve spring at the specified installed length.

Installed tension:

164 – 189 N (16.7 – 19.3 kgf, 36.8 – 42.5 lbf)

at 34.7 mm (1.366 in.)

If the installed tension is not as specified, replace the valve spring.

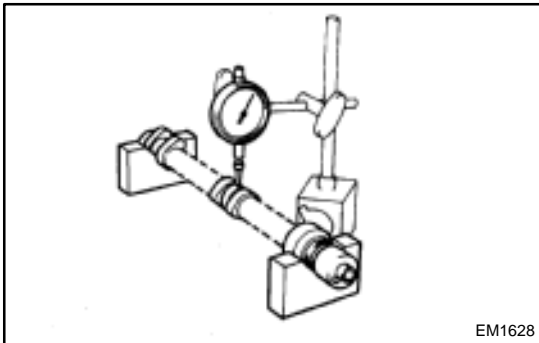

10. INSPECT CAMSHAFTS

(a) Inspect the circle runout.

(1) Place the camshaft on V-blocks.

(2) Using a dial indicator, measure the circle runout at the center journal.

Maximum circle runout: 0.04 mm (0.0016 in.)

If the circle runout is greater than maximum, replace the camshaft.

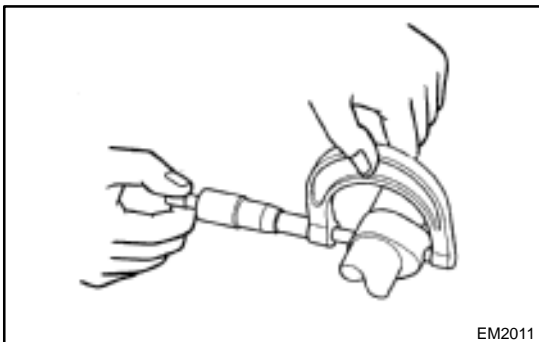

(b) Using a micrometer, measure the cam lobe height.

Standard cam lobe height:

Intake	42.01 – 42.11 mm (1.6539 – 1.6579 in.)
Exhaust	40.06 – 40.16 mm (1.5772 – 1.5811 in.)

Minimum cam lobe height:

Intake	41.90 mm (1.6496 in.)
Exhaust	39.95 mm (1.5728 in.)

If the cam lobe height is less than minimum, replace the camshaft.

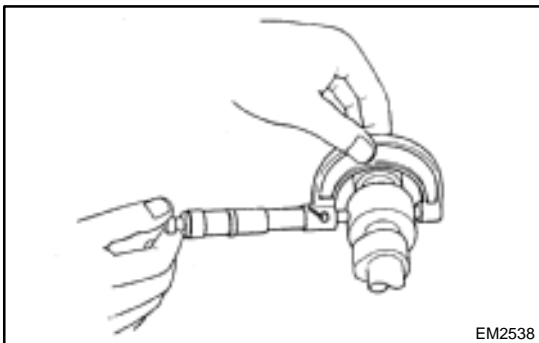

(c) Using a micrometer, measure the journal diameter.

Journal diameter:

26.959 – 26.975 mm (1.0614 – 1.0620 in.)

If the journal diameter is not as specified, check the oil clearance.

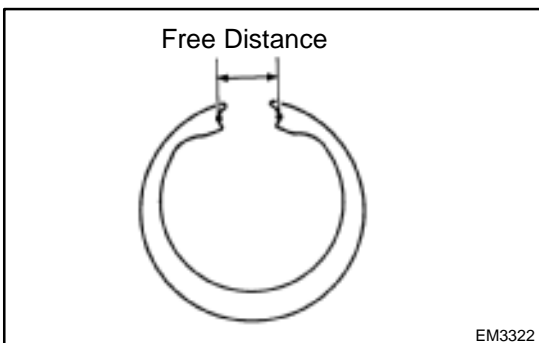

(d) Using vernier calipers, measure the free distance between the gear spring ends.

Free distance: 22.5 – 22.9 mm (0.886 – 0.902 in.)

If the free distance is not as specified, replace the gear spring.

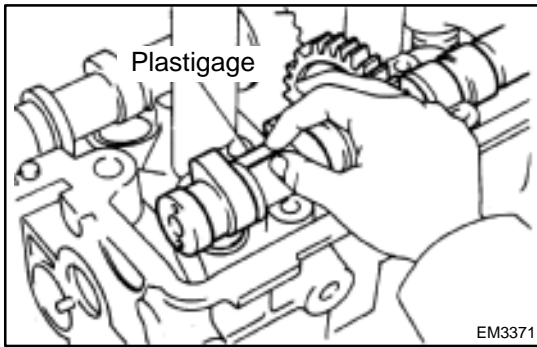

- (e) Inspect the journal oil clearance.
- (1) Clean the bearing caps and camshaft journals.
 - (2) Check that bearings for flaking and scoring.
- If the bearings are damaged, replace the bearing caps and cylinder head as a set.
- (3) Place the camshafts on the cylinder head.
 - (4) Lay a strip of Plastigage across each of the camshaft journals.

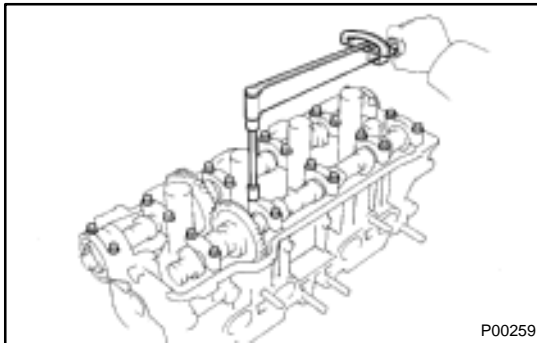

- (5) Install the bearing caps. (See page EM-53)

NOTICE:

Do not turn the camshaft.

- (6) Remove the bearing caps.

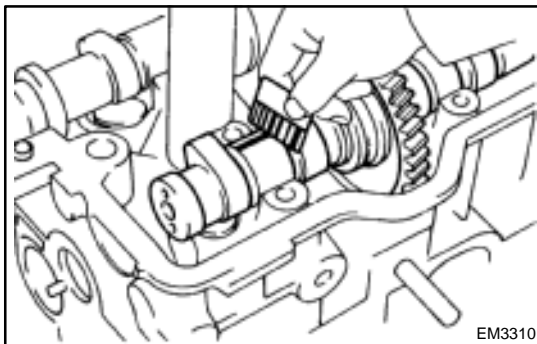

- (7) Measure the Plastigage at its widest point.

Standard oil clearance:

0.025 – 0.062 mm (0.0010 – 0.0024 in.)

Maximum oil clearance: 0.10 mm (0.0039 in.)

If the oil clearance is greater than maximum, replace the camshaft. If necessary, replace the bearing caps and cylinder head as a set.

- (8) Completely remove the Plastigage.

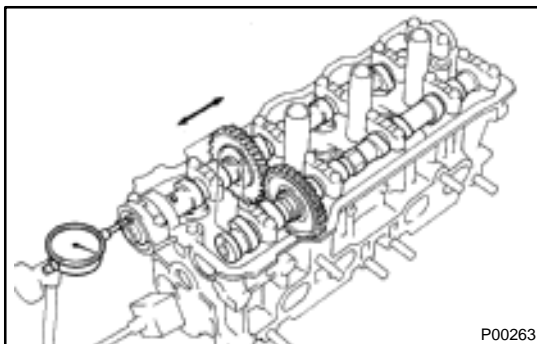

- (f) Inspect the camshaft thrust clearance.
- (1) Install the camshaft. (See page EM-53)
 - (2) Using a dial indicator, measure the thrust clearance while moving the camshaft back and forth.

Standard thrust clearance:

Intake	0.045 – 0.100 mm (0.0018 – 0.0039 in.)
Exhaust	0.030 – 0.085 mm (0.0012 – 0.0033 in.)

Maximum thrust clearance:

Intake	0.12 mm (0.0047 in.)
Exhaust	0.10 mm (0.0039 in.)

If the thrust clearance is greater than maximum, replace the camshaft. If necessary, replace the bearing caps and cylinder head as a set.

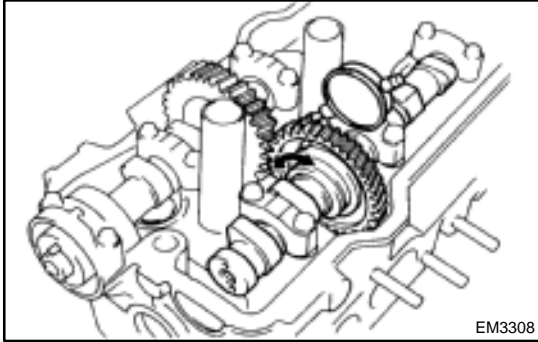

- (g) Inspect the camshaft gear backlash.
- (1) Install the camshafts without installing the exhaust cam sub-gear. (See page EM-53)
 - (2) Using a dial indicator, measure the backlash.

Standard backlash:

0.020 – 0.200 mm (0.0008 – 0.0079 in.)

Maximum backlash: 0.30 mm (0.0188 in.)

If the backlash is greater than maximum, replace the camshafts.

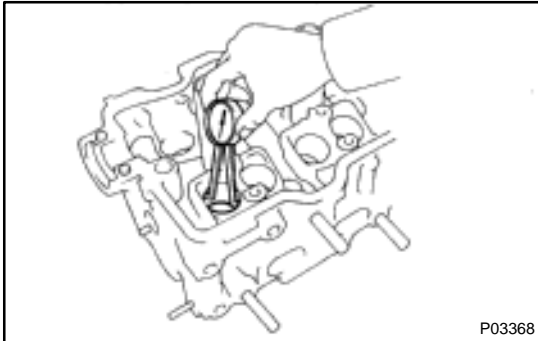

11. INSPECT VALVE LIFTERS AND LIFTER BORES

- (a) Using a caliper gauge, measure the lifter bore diameter of the cylinder head.

Lifter bore diameter:

31.000 – 31.018 mm (1.2205 – 1.2212 in.)

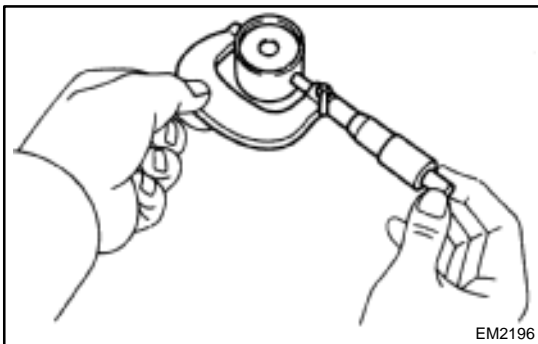

- (b) Using a micrometer, measure the lifter diameter.

Lifter diameter:

30.966 – 30.976 mm (1.2191 – 1.2195 in.)

- (c) Subtract the lifter diameter measurement from the lifter bore diameter measurement.

Standard oil clearance:

0.024 – 0.052 mm (0.0009 – 0.0020 in.)

Maximum oil clearance: 0.07 mm (0.0028 in.)

If the oil clearance is greater than maximum, replace the lifter. If necessary, replace the cylinder head.

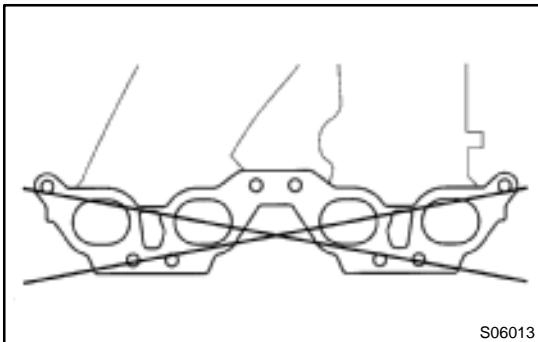

12. INSPECT INTAKE MANIFOLD

Using a precision straight edge and feeler gauge, measure the surface contacting the cylinder head for warpage.

Maximum warpage: 0.30 mm (0.0118 in.)

If warpage is greater than maximum, replace the manifold.

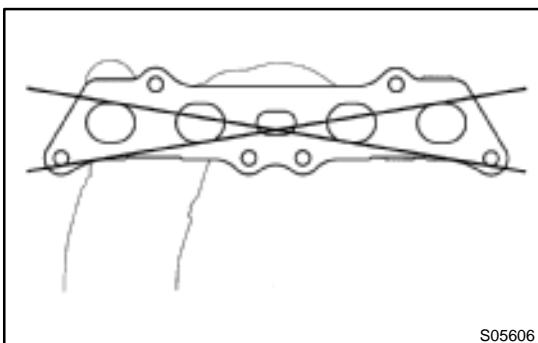

13. INSPECT EXHAUST MANIFOLD

Using a precision straight edge and feeler gauge, measure the surface contacting the cylinder head for warpage.

Maximum warpage: 0.30 mm (0.0118 in.)

If warpage is greater than maximum, replace the manifold.

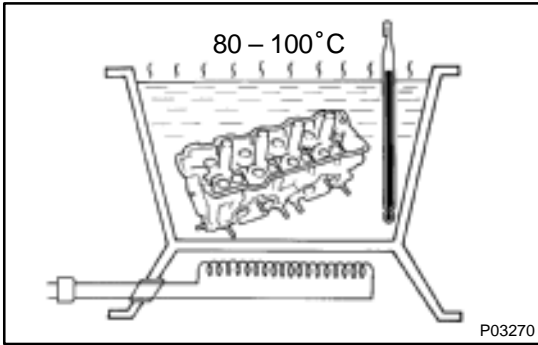

REPLACEMENT

REPLACE VALVE GUIDE BUSHINGS

(a) Gradually heat the cylinder head to 80 – 100°C (176 – 212°F).

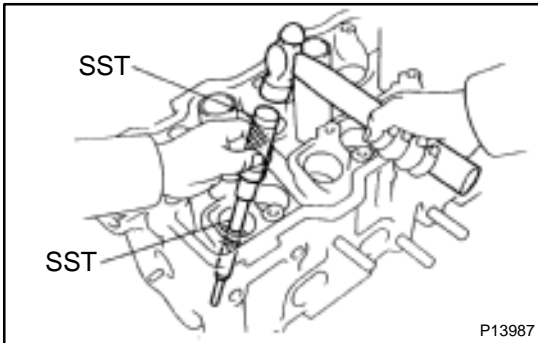

(b) Using SST and a hammer, tap out the guide bushing.
 SST 09201-10000 (09201-01060),
 09950-70010 (09951-07100)

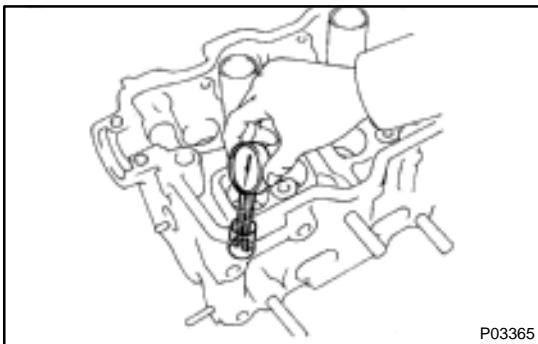

(c) Using a caliper gauge, measure the bushing bore diameter of the cylinder head.

Both intake and exhaust

Bushing bore diameter mm (in.)	Bushing size
10.985 – 11.012 (0.4325 – 0.4335)	Use STD
11.035 – 11.062 (0.4344 – 0.4355)	Use O/S 0.05

(d) Select a new guide bushing (STD or O/S 0.05).

If the bushing bore diameter of the cylinder head is greater than 11.012 mm (0.4335 in.), machine the bushing bore to the following dimension:

11.035 – 11.062 mm (0.4344 – 0.4355 in.)

If the bushing bore diameter of the cylinder head is greater than 11.062 mm (0.4355 in.), replace the cylinder head.

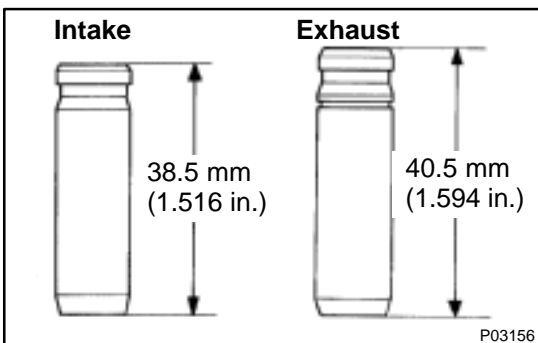

HINT:

Different the bushings are used for the intake and exhaust.

(e) Gradually heat the cylinder head to 80 – 100°C (176 – 212°F).

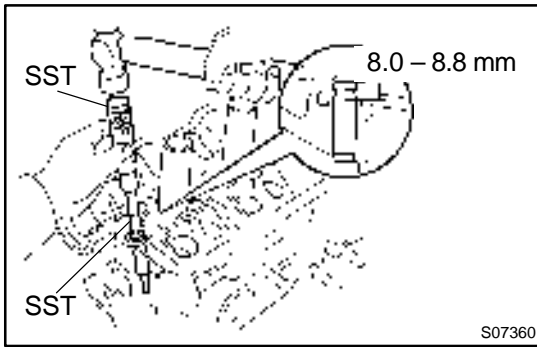

- (f) Using SST and a hammer, tap in a new guide bushing until there is 8.0 – 8.8 mm (0.315 – 0.346 in.) protruding from the cylinder head.

SST 09201-10000 (09201-01060),
09950-70010 (09951-07100)

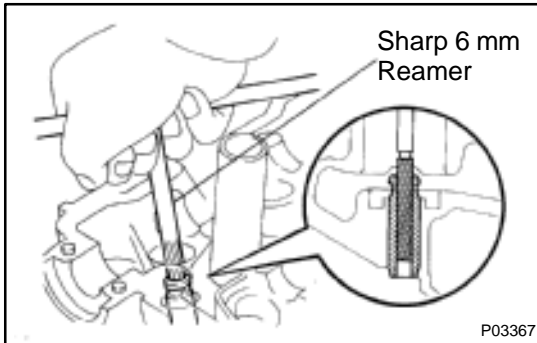

- (g) Using a sharp 6 mm reamer, ream the guide bushing to obtain the standard specified clearance (See page EM-42) between the guide bushing and valve stem.

REASSEMBLY

HINT:

Thoroughly clean all parts to be assembled.

Before installing the parts, apply new engine oil to all sliding and rotating surfaces.

Replace all gaskets and oil seals with new ones.

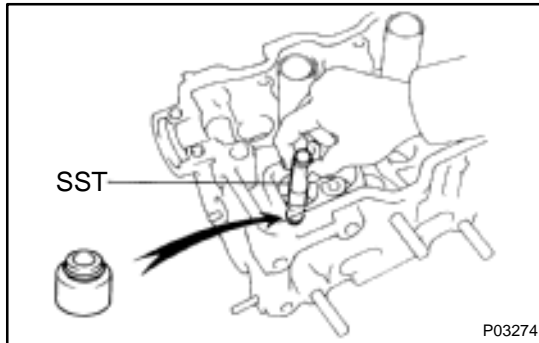

1. INSTALL VALVES

- (a) Using SST, push in a new oil seal.

SST 09201-41020

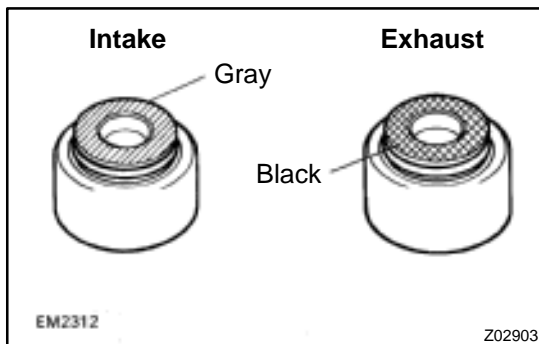

HINT:

The intake valve oil seal is gray and the exhaust valve oil seal is black.

- (b) Install the valve, spring seat, valve spring and spring retainer.

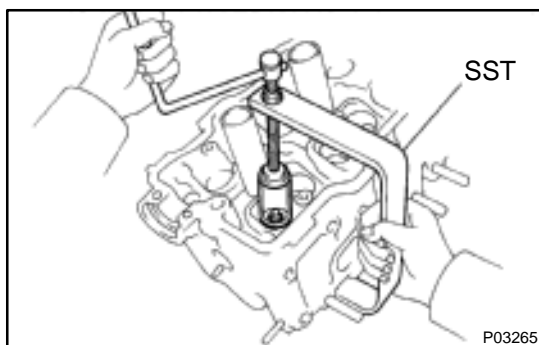

- (c) Using SST, compress the valve spring and place the 2 keepers around the valve stem.

SST 09202-70020 (09202-00010)

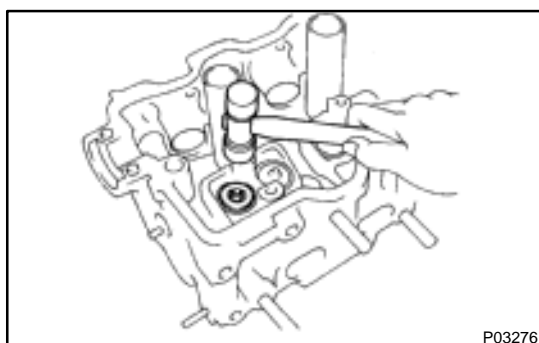

- (d) Using a plastic-faced hammer, lightly tap the valve stem tip to assure a proper fit.

2. INSTALL VALVE LIFTERS AND SHIMS

- (a) Install the valve lifter and shim.

- (b) Check that the valve lifter rotates smoothly by hand.

3. INSTALL CAMSHAFT POSITION SENSOR ASSEMBLY

Install the sensor assembly with the bolt.

Torque: 9.5 N·m (97 kgf·cm, 84 in.-lbf)

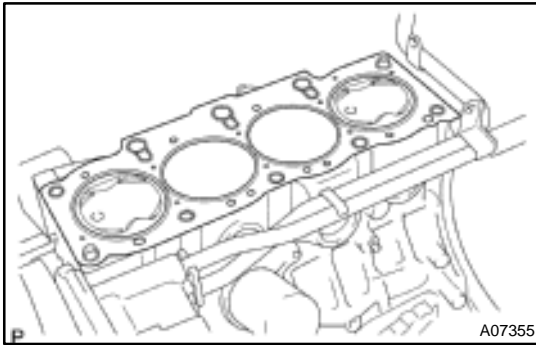

INSTALLATION

1. PLACE CYLINDER HEAD ON CYLINDER BLOCK

- (a) Place a new cylinder head gasket on the cylinder block.

NOTICE:

Be careful of the installation direction.

- (b) Place the cylinder head on the cylinder head gasket.

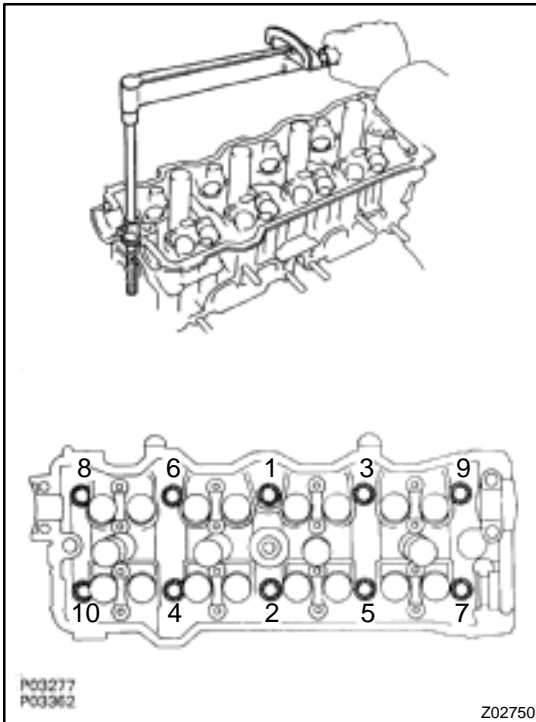

2. INSTALL CYLINDER HEAD BOLTS

HINT:

The cylinder head bolts are tightened in 2 progressive steps (steps (b) and (d)).

If any cylinder head bolt is broken or deformed, replace it.

- (a) Apply a light coat of engine oil on the threads and under the heads of the cylinder head bolts.
- (b) Install and uniformly tighten the 10 cylinder head bolts and plate washers in several passes, in the sequence shown.

Torque: 49 N·m (500 kgf·cm, 36 ft·lbf)

If any one of the cylinder head bolts does not meet the torque specification, replace the cylinder head bolt.

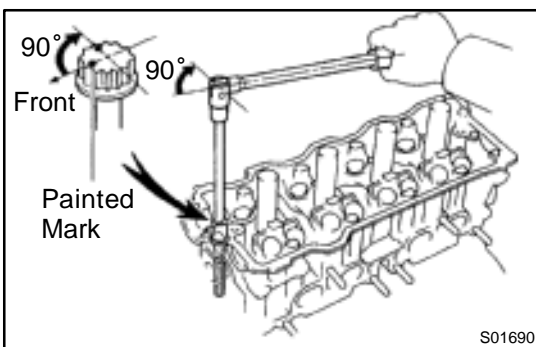

- (c) Mark the front of the cylinder head bolt head with paint.
- (d) Retighten the cylinder head bolts 90° in the numerical order shown.
- (e) Check that the painted mark is now at a 90° angle to the front.
- (f) Install the 2 bolts holding the water bypass pipe to the cylinder head.

Torque: 19 N·m (195 kgf·cm, 14 ft·lbf)

- (g) Connect the camshaft position sensor connector.

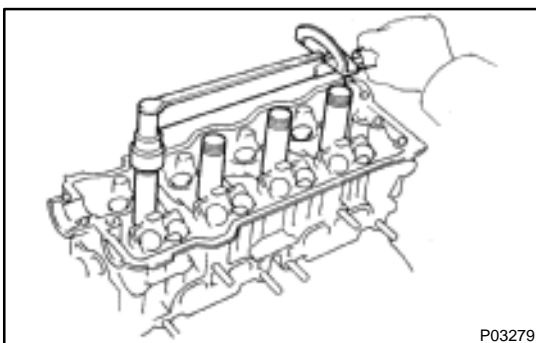

3. INSTALL SPARK PLUG TUBES

- (a) Clean the cylinder head tube holes of any residual adhesive, oil or foreign particles. Remove any oil with kerosene or gasoline.
- (b) Screw the threads of the spark plug tube coated with adhesive into the cylinder head.
- (c) Using the spark plug tube nut and a 30 mm socket wrench, tighten the spark plug tubes.

Torque: 49 N·m (500 kgf·cm, 36 ft·lbf)

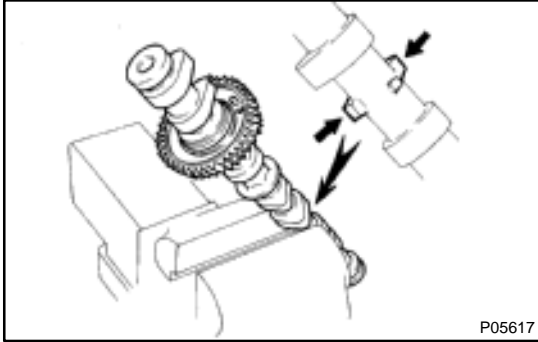

4. ASSEMBLE EXHAUST CAMSHAFT

(a) Mount the camshaft in a vise.

NOTICE:

Be careful not to damage the camshaft.

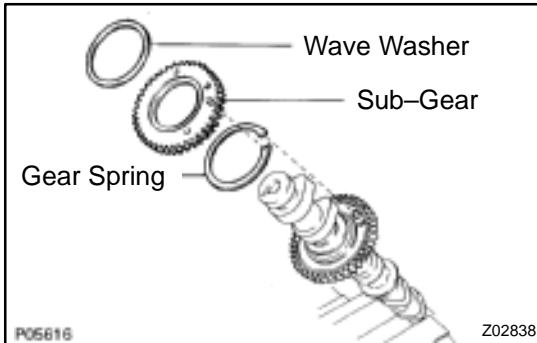

(b) Install the camshaft gear spring, camshaft sub-gear and wave washer.

HINT:

Align the pins on the gears with the spring ends.

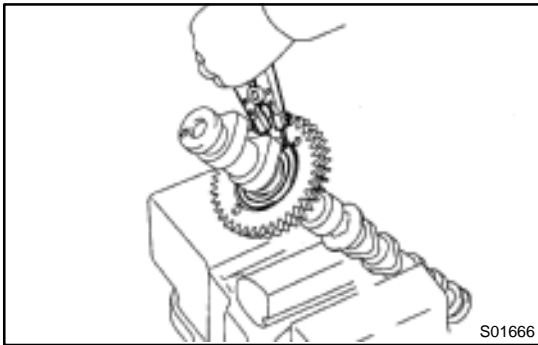

(c) Using snap ring pliers, install the snap ring.

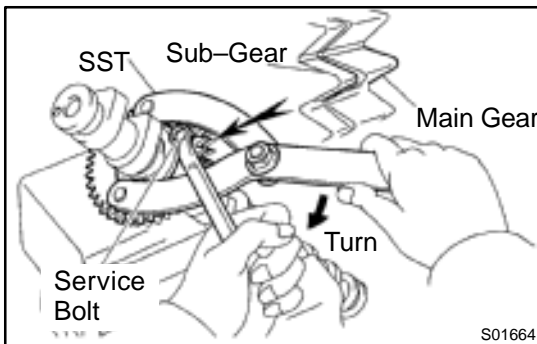

(d) Using SST, align the holes of the camshaft drive gear and sub-gear by turning camshaft sub-gear clockwise, and install a service bolt.

SST 09960-10010 (09962-01000, 09963-00500)

(e) Align the gear teeth of the drive gear and sub-gear, and tighten the service bolt.

5. INSTALL CAMSHAFTS

NOTICE:

Since the thrust clearance of the camshaft is small, the camshaft must be kept level while it is being installed. If the camshaft is not kept level, the portion of the cylinder head receiving the shaft thrust may crack or be damaged, causing the camshaft to seize or break. To avoid this, the following steps should be carried out.

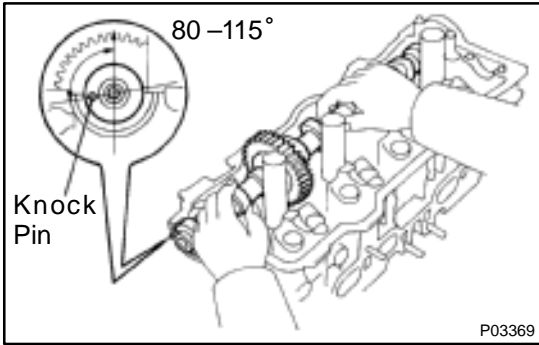

- (a) Install the intake camshaft.
 - (1) Apply MP grease to the thrust portion of the camshaft.
 - (2) Place the intake camshaft at 80 – 115° BTDC of camshaft angle on the cylinder head.

HINT:

The above angle arrows the No.1 and No.3 cylinder cam lobes of the intake camshaft to push their valve lifters evenly.

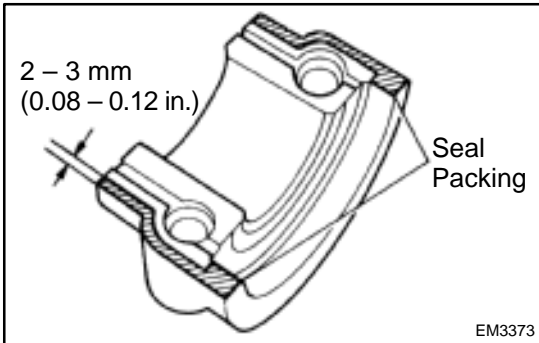

- (3) Apply seal packing to the No.1 bearing cap as shown.

Seal packing: Part No. 08826-00080 or equivalent

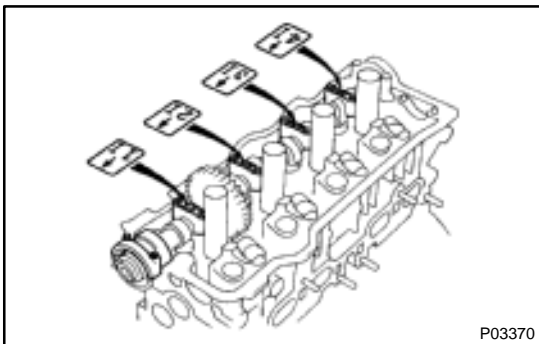

- (4) Install the bearing caps in their proper locations.

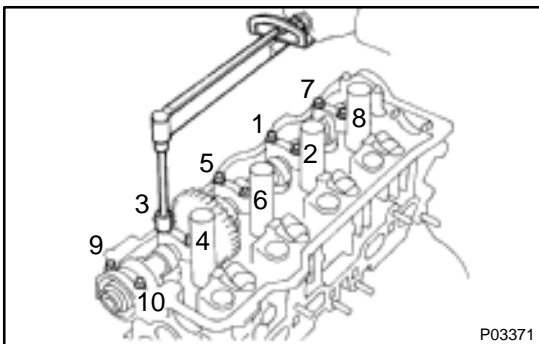

- (5) Apply a light coat of engine oil on the threads and under the heads of the bearing cap bolts.
- (6) Install and uniformly tighten the 10 bearing cap bolts in several passes, in the sequence shown.

Torque: 19 N·m (190 kgf·cm, 14 ft·lbf)

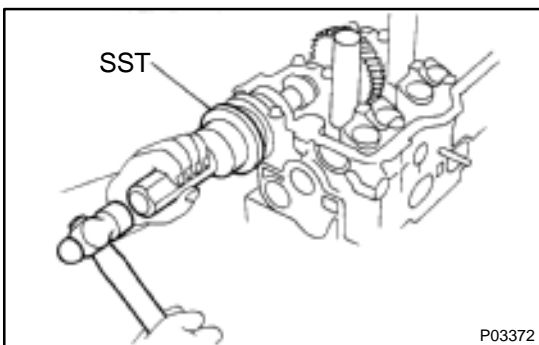

- (7) Apply MP grease to a new oil seal lip.
 - (8) Using SST and a hammer, tap in the oil seal.
- SST 09223-46011

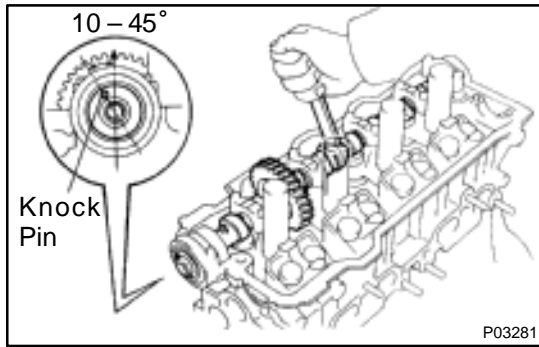

(b) Install the exhaust camshaft.

- (1) Set the knock pin of the intake camshaft at 10 – 45° BTDC of camshaft angle.

HINT:

The above angle allows the No.2 and No.4 cylinder cam lobes of the exhaust camshaft to push their valve lifters evenly.

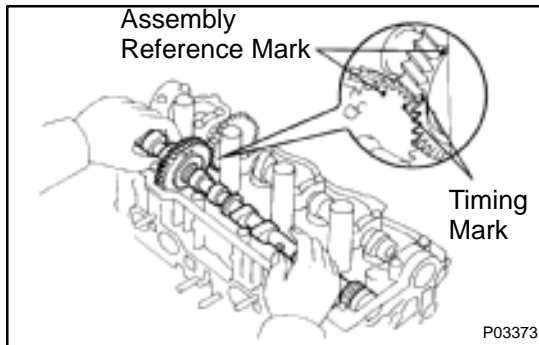

- (2) Apply MP grease to the thrust portion of the camshaft.
- (3) Engage the exhaust camshaft gear to the intake camshaft gear by matching the timing marks on each gear.
- (4) Roll down the exhaust camshaft onto the bearing journals while engaging gears with each other.

NOTICE:

There are also assembly reference marks on each gear as shown in the illustration. Do not use these marks.

- (5) Turn the intake camshaft clockwise or counterclockwise a little until the exhaust camshaft sits in the bearing journals evenly without rocking the camshaft on the bearing journals.

NOTICE:

It is very important to replace the camshaft in the bearing journals evenly while tightening bearing caps in the subsequent steps.

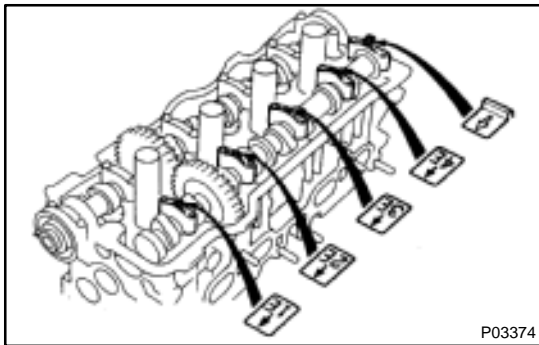

- (6) Install the bearing caps in their proper locations.

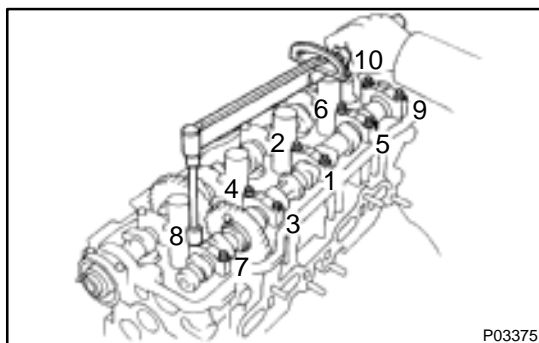

- (7) Apply a light coat of engine oil on the threads and under the heads of the bearing cap bolts.
- (8) Install and uniformly tighten the 10 bearing cap bolts in several passes, in the sequence shown.

Torque: 19 N·m (190 kgf·cm, 14 ft·lbf)

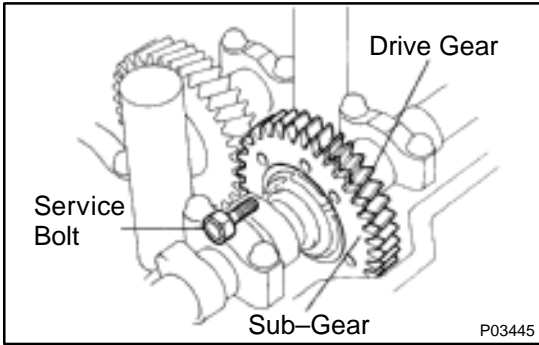

(9) Remove the service bolt.

6. CHECK AND ADJUST VALVE CLEARANCE (See page EM-4)

Turn the camshaft and position the cam lobe upward, and inspect and adjust the valve clearance.

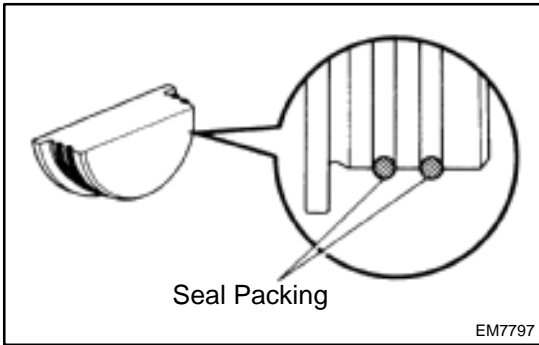

7. INSTALL SEMI-CIRCULAR PLUGS

- (a) Remove any old packing (FIPG) material.
- (b) Apply seal packing to the semi-circular plug grooves.
Seal packing: Part No. 08826-00080 or equivalent

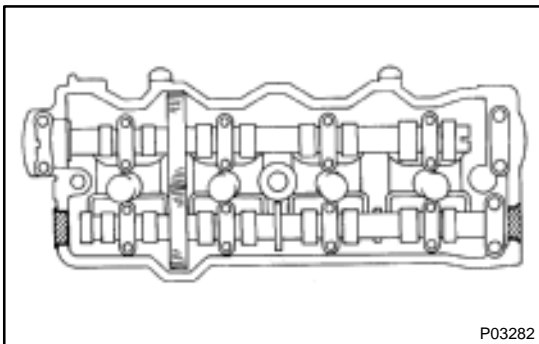

- (c) Install the 2 semi-circular plugs to the cylinder head.

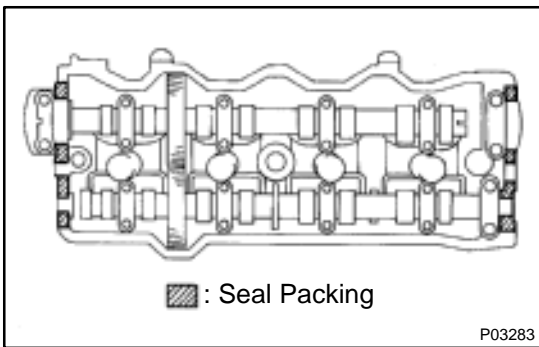

8. INSTALL CYLINDER HEAD COVER

- (a) Remove any old packing (FIPG) material.
- (b) Apply seal packing to the cylinder head as shown in the illustration.
Seal packing: Part No. 08826-00080 or equivalent

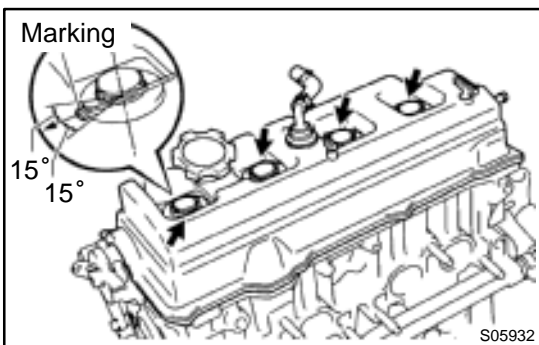

- (c) Install the gasket to the head cover.
- (d) Install the head cover with the 4 grommets and nuts. Uniformly tighten the nuts in several passes.
Torque: 44 N·m (450 kgf-cm, 33 ft-lbf)

HINT:
Install the grommets so that their markings are as shown in the illustration.

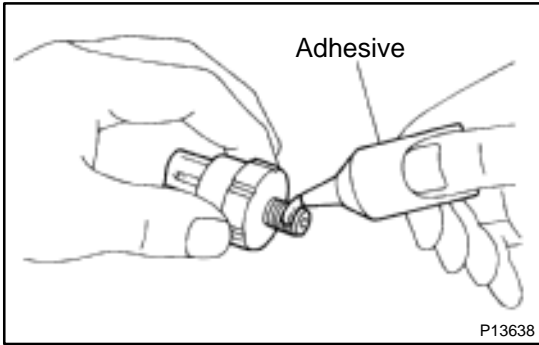

9. INSTALL OIL PRESSURE SWITCH

- (a) Apply adhesive to 2 or 3 threads.

Adhesive:

Part No. 08833-00080, THREE BOND 1324 or equivalent

- (b) Install the oil pressure switch.

10. INSTALL ENGINE HANGERS AND GENERATOR BRACKET

- (a) Install the generator bracket and RH engine hanger assembly with the 3 bolts.

Torque: 42 N-m (425 kgf-cm, 31 ft-lbf)

- (b) Install the LH engine hanger with the bolt.

Torque: 25 N-m (250 kgf-cm, 18 ft-lbf)

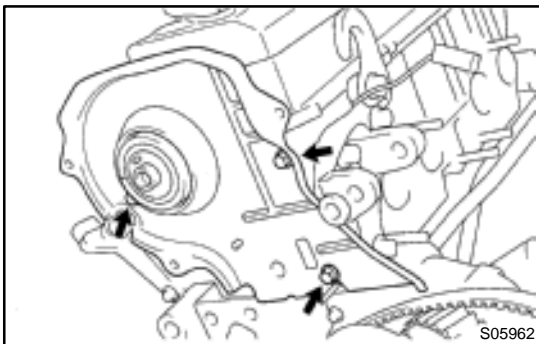

11. INSTALL NO.3 TIMING BELT COVER

Install the timing belt cover with the 3 bolts.

Torque: 7.8 N-m (80 kgf-cm, 69 in.-lbf)

12. TEMPORARILY INSTALL NO.1 IDLER PULLEY AND TENSION SPRING (See page EM-23)

13. INSTALL CAMSHAFT TIMING PULLEY (See page EM-23)

14. CONNECT TIMING BELT TO CAMSHAFT TIMING PULLEY (See page EM-23)

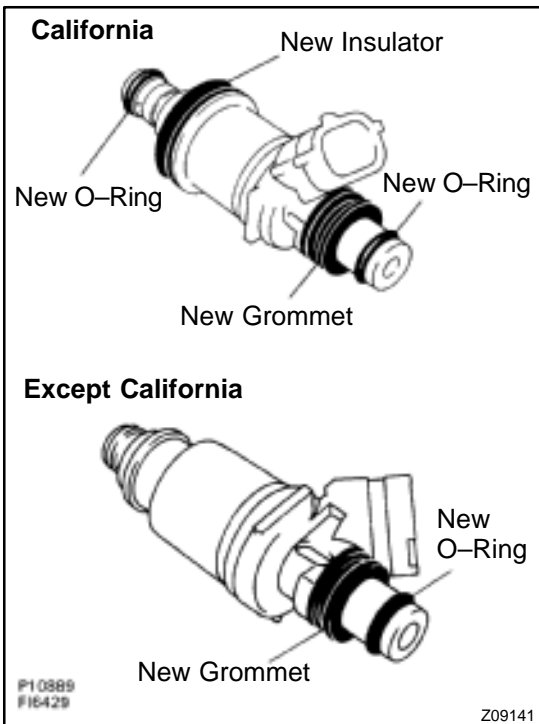

15. INSTALL INJECTORS AND DELIVERY PIPE

- (a) California:

Install a new insulator and grommet to each injector.

- (b) Except California:

Install a new grommet to each injector.

- (c) California:

Apply a light coat of gasoline onto 2 new O-rings, and install them to each injector.

- (d) Except California:

Apply a light coat of gasoline onto a new O-ring, and install it to each injector.

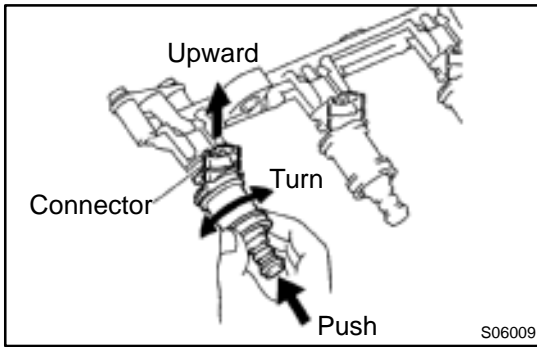

- (e) While turning the injector clockwise and counterclockwise, push it to the delivery pipe. Install the 6 injectors.
- (f) Position the injector connector upward.

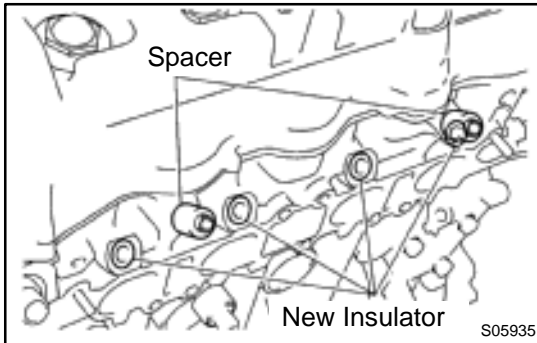

- (g) Install the 2 spacers and 4 new insulators (Except California) to the cylinder head.

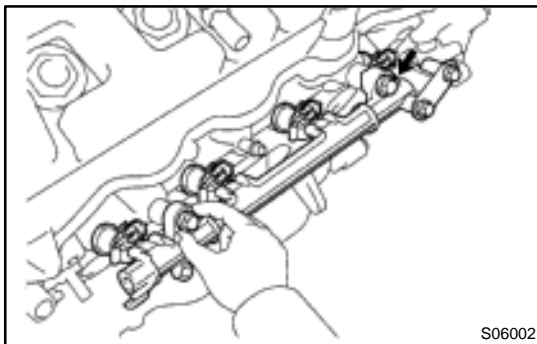

- (h) Attach the 4 injectors together with the delivery pipe to the cylinder head.
- (i) Temporarily install the 2 bolts holding the delivery pipe to the cylinder head.

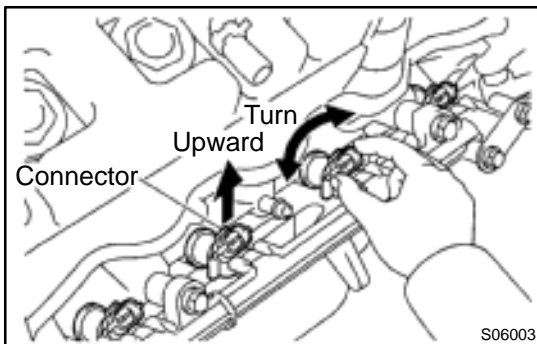

- (j) Check that the injectors rotate smoothly.
HINT:
If injectors do not rotate smoothly, the probable cause is incorrect installation of O-rings. Replace the O-rings.
- (k) Position the injector connector upward.

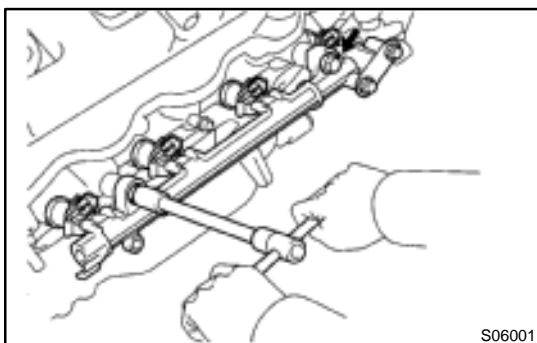

- (l) Tighten the 2 bolts holding the delivery pipe to the cylinder head.
Torque: 13 N·m (130 kgf-cm, 9 ft-lbf)

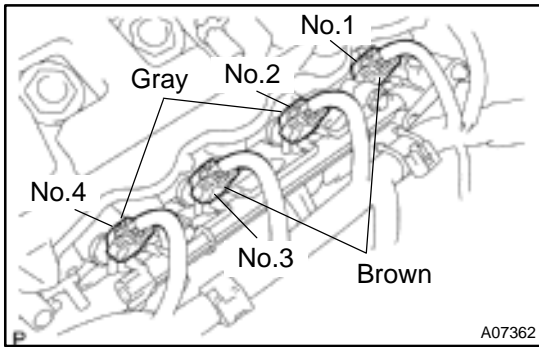

(m) Connect the 4 injector connectors.

HINT:

The No.1 and No.3 injector connectors are brown, and the No.2 and No.4 injector connectors are gray.

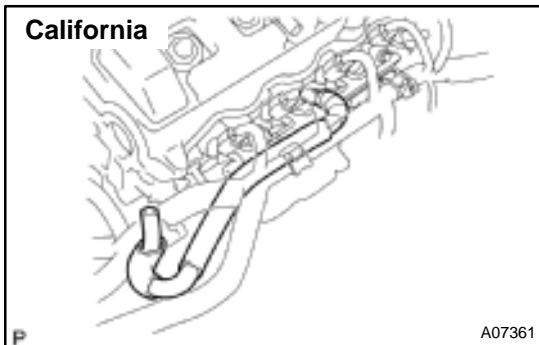

16. California:

INSTALL AIR HOSE FOR AIR ASSIST SYSTEM

Connect the air hose to the cylinder head port.

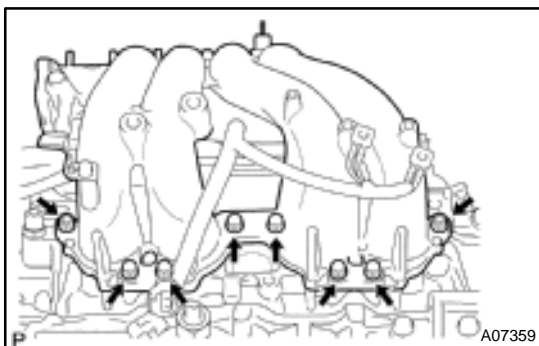

17. INSTALL INTAKE MANIFOLD

(a) Install a new gasket and the intake manifold with the 6 bolts and 2 nuts. Uniformly tighten the bolts and nuts in several passes.

Torque: 19 N·m (195 kgf·cm, 14 ft·lbf)

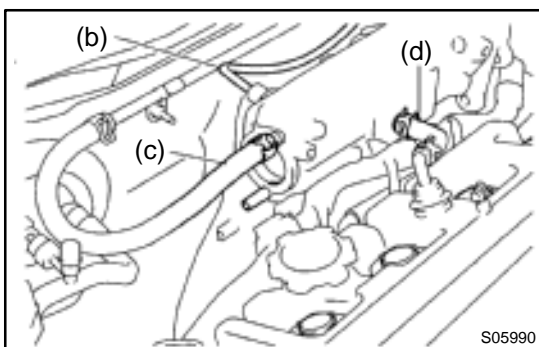

- (b) Connect the MAP sensor vacuum hose to the gas filter.
- (c) Connect the brake booster vacuum hose to the intake manifold.
- (d) Connect the PCV hose to the intake manifold.

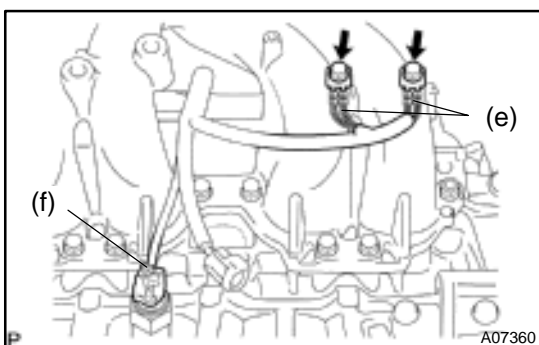

- (e) Connect the 2 ground wires to the intake manifold with the 2 bolts.
- (f) Connect the knock sensor 1 connector.

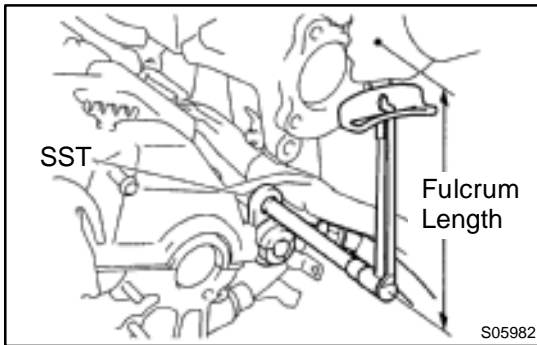

- 18. CONNECT FUEL INLET HOSE TO DELIVERY PIPE**
 (a) Temporarily connect the fuel inlet hose with 2 new gaskets and fuel pulsation damper.

- (b) Using SST, tighten the fuel pulsation damper.

SST 09612-24014 (09617-24011)

Torque:

34 N·m (350 kgf·cm, 25 ft·lbf)

29 N·m (300 kgf·cm, 21 ft·lbf) for use with SST

HINT:

Use a torque wrench with a fulcrum length of 30 cm (1.181 in.).

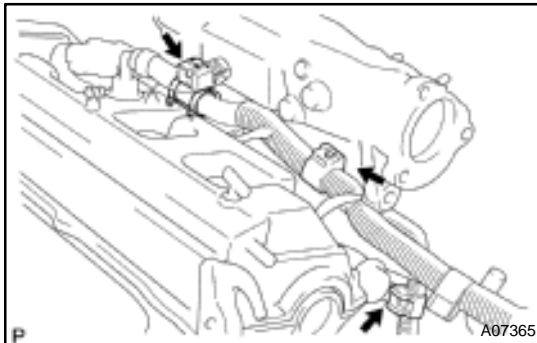

19. INSTALL ENGINE WIRE

- (a) Install the 2 engine wire clamps to the 2 brackets on the front side of the intake manifold.

- (b) Install the engine wire clamp to the bracket on the LH side of the intake manifold.

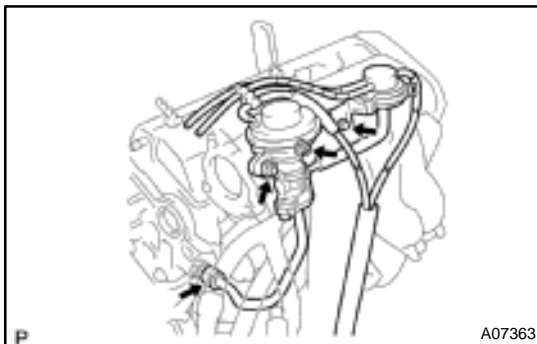

20. INSTALL EGR VALVE AND VACUUM MODULATOR

- (a) Install a new gasket, the EGR valve, EGR pipe and vacuum modulator assembly with the union nut, 2 nuts and bolt.

Torque:

13.3 N·m (136 kgf·cm, 10 ft·lbf) for nut

61.2 N·m (624 kgf·cm, 45 ft·lbf) for union nut

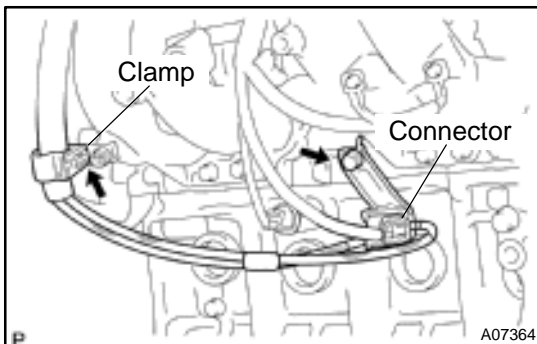

- (b) Install the hose clamp to the bracket on the intake manifold.

- (c) Install the VSV for the EGR with the bolt.

- (d) Connect the VSV connector for the EGR.

21. INSTALL INTAKE MANIFOLD STAY

Install the intake manifold stay with the bolt and nut.

Torque: 39 N·m (398 kgf·cm, 29 ft·lbf)

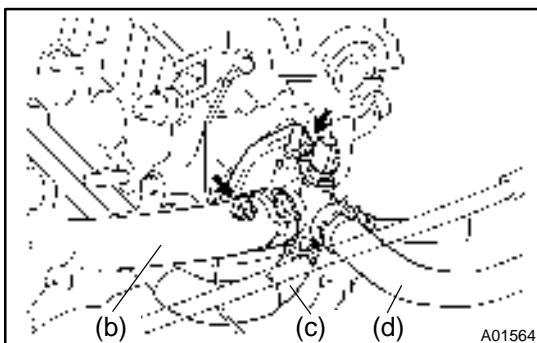

22. INSTALL WATER OUTLET

- (a) Install a new gasket and the water outlet with the 2 nuts.
Torque: 15 N·m (150 kgf·cm, 11 ft·lbf)

- (b) Connect the radiator hose to the water outlet.

- (c) Connect the water bypass pipe hose to the water outlet.

- (d) Connect the heater water hose to the water outlet.

- (e) Connect the ECT sensor connector.

- (f) Connect the ECT sender gauge connector.

23. CONNECT OIL PRESSURE SWITCH CONNECTOR

24. CONNECT NOISE FILTER CONNECTOR



25. INSTALL IGNITION COILS AND NO.2 INTAKE MANIFOLD STAY ASSEMBLY

- (a) TMC Made:
Install the 2 ignition coils and manifold stay assembly with the 2 nuts and 2 bolts.

Torque:

21 N·m (214 kgf·cm, 15 ft·lbf) for 12 mm head

42 N·m (428 kgf·cm, 31 ft·lbf) for 14 mm head

- (b) TMMK Made:
Install the 2 ignition coils and manifold stay assembly with the nut and 3 bolts.

Torque:

21 N·m (214 kgf·cm, 15 ft·lbf) for 12 mm head

42 N·m (428 kgf·cm, 31 ft·lbf) for 14 mm head

- (c) Install the wire clamp to the manifold stay.
(d) Connect the 4 high-tension cords to the spark plugs.
(e) Install the 4 high-tension cords to the 2 clamps on the cylinder head cover.
(f) Connect the 2 ignition coil connectors.

26. INSTALL THROTTLE BODY (See page SF-34)

27. INSTALL EXHAUST MANIFOLD

- (a) California:
Install the A/F sensor connector for the wiring side to the bracket to the LH engine hanger.

- (b) Except California:
Install the heated oxygen sensor for the wiring side to the bracket to the LH engine hanger.

- (c) Attach the exhaust manifold to the front exhaust pipe.
(d) Install a new gasket, the exhaust manifold, No.2 and No.3 exhaust manifold heat insulators assembly with the 6 nuts. Uniformly tighten the nuts in several passes.

Torque: 49 N·m (500 kgf·cm, 36 ft·lbf)

- (e) Install the wire clamp.
(f) California:
Connect the A/F sensor connector.
(g) Except California:
Connect the heated oxygen sensor (bank 1 sensor 1) connector.

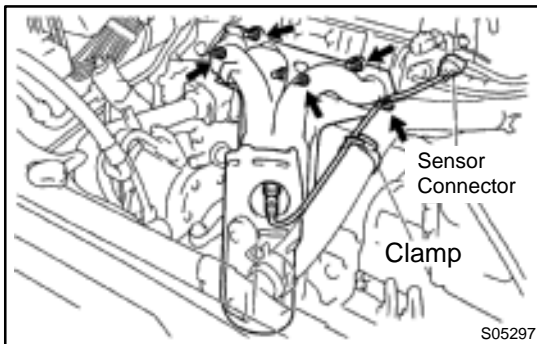

- (h) Install the No.1 exhaust manifold stay with the 2 bolts.

Torque: 42 N·m (425 kgf·cm, 31 ft·lbf)

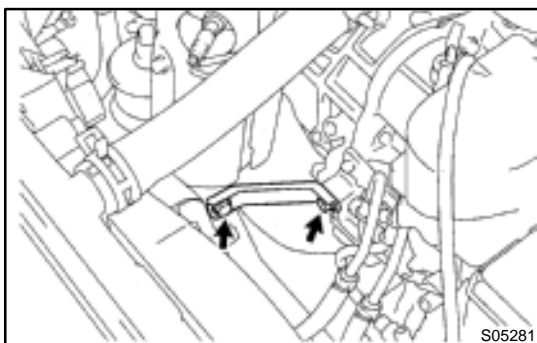

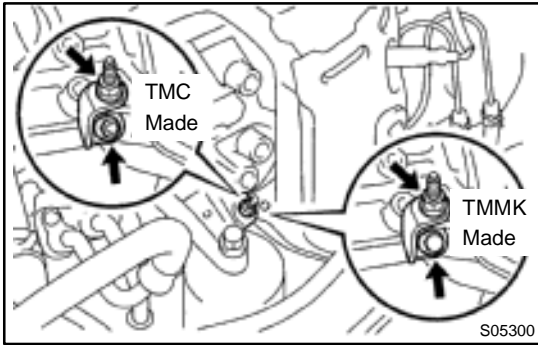

- (i) TMC Made:
Install the No.2 exhaust manifold stay with the 2 nuts.
Torque:
42 N·m (425 kgf·cm, 31 ft·lbf) for manifold side
58 N·m (591 kgf·cm, 43 ft·lbf) for block side
- (j) TMMK Made:
Install the No.2 exhaust manifold stay with the bolt and nut.
Torque:
42 N·m (425 kgf·cm, 31 ft·lbf) for manifold side
41.5 N·m (423 kgf·cm, 31 ft·lbf) for block side
- (k) Install the No.1 exhaust manifold heat insulator with the 3 (California) or 5 (Except California) bolts.

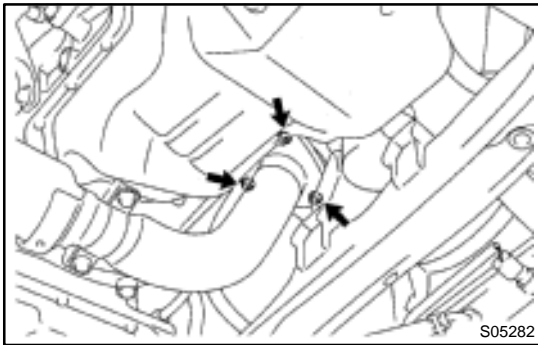

- (l) Install 3 new nuts holding the front exhaust pipe to the exhaust manifold.
Torque: 62 N·m (630 kgf·cm, 46 ft·lbf)
- 28. INSTALL GENERATOR (See page CH-16)**
29. INSTALL AIR CLEANER CASE (See page EM-75)
30. FILL WITH ENGINE COOLANT
31. START ENGINE AND CHECK FOR LEAKS
32. RECHECK ENGINE COOLANT LEVEL AND OIL LEVEL

ENGINE UNIT COMPONENTS

EM0YV-01

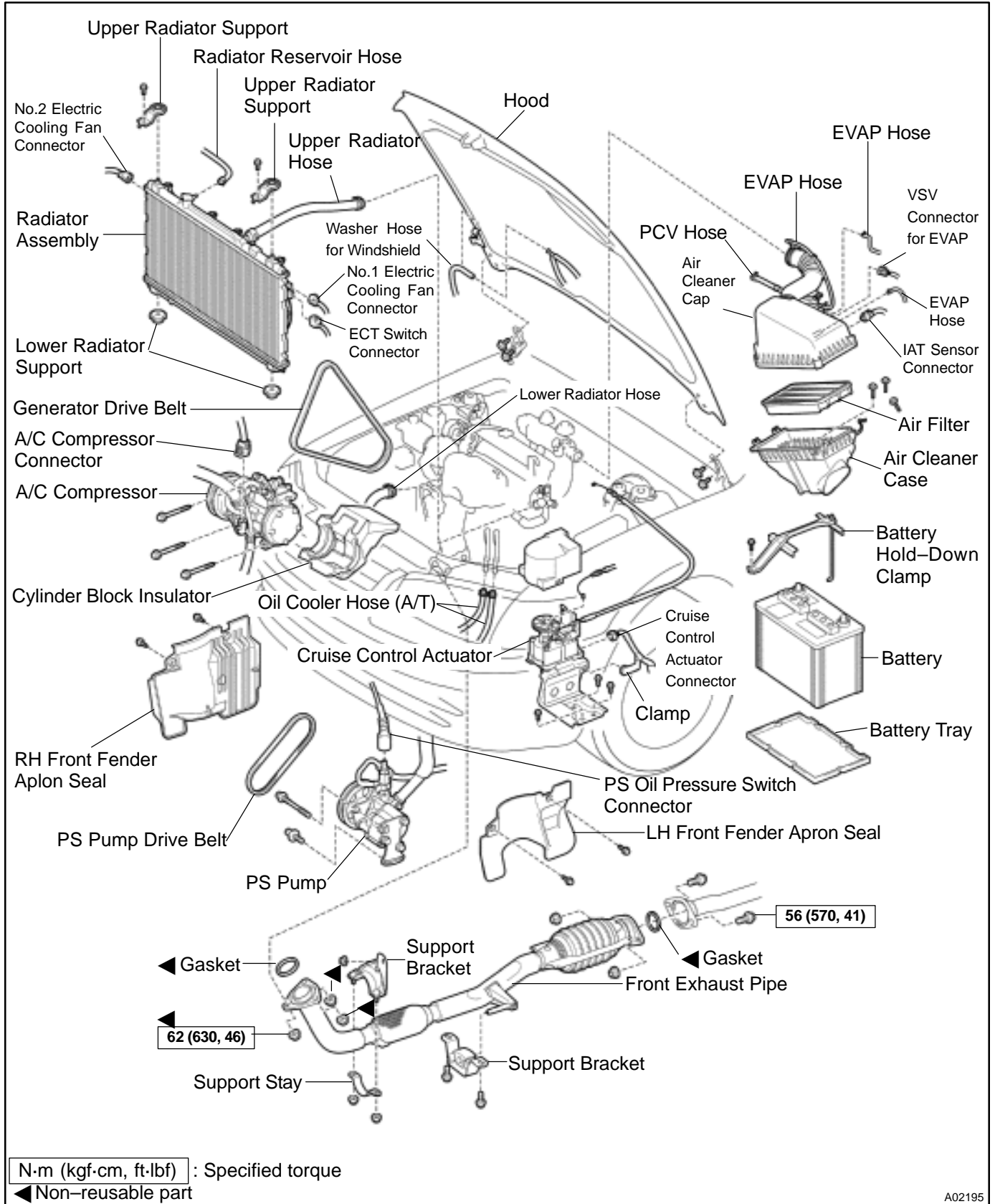

A02195

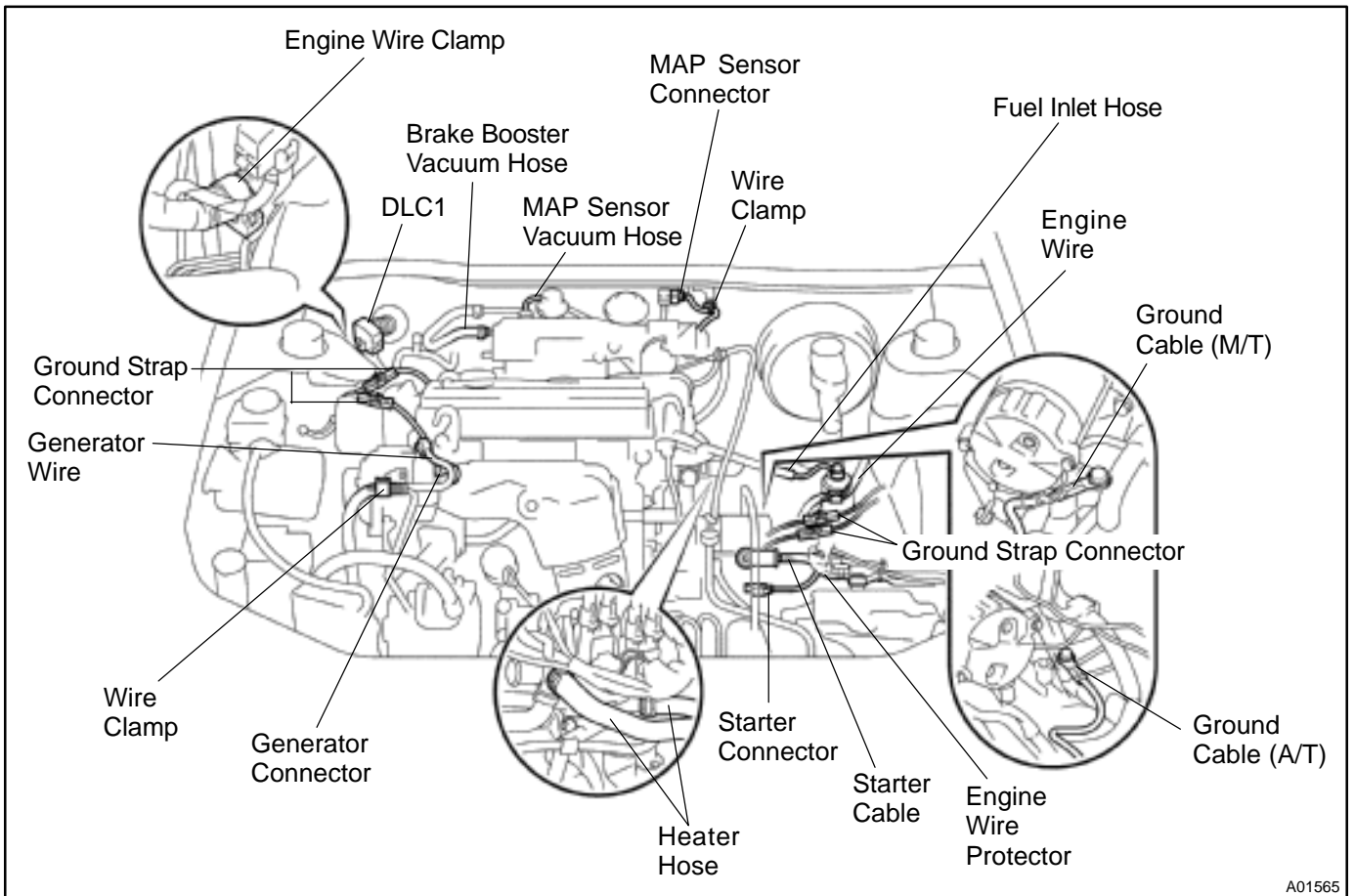
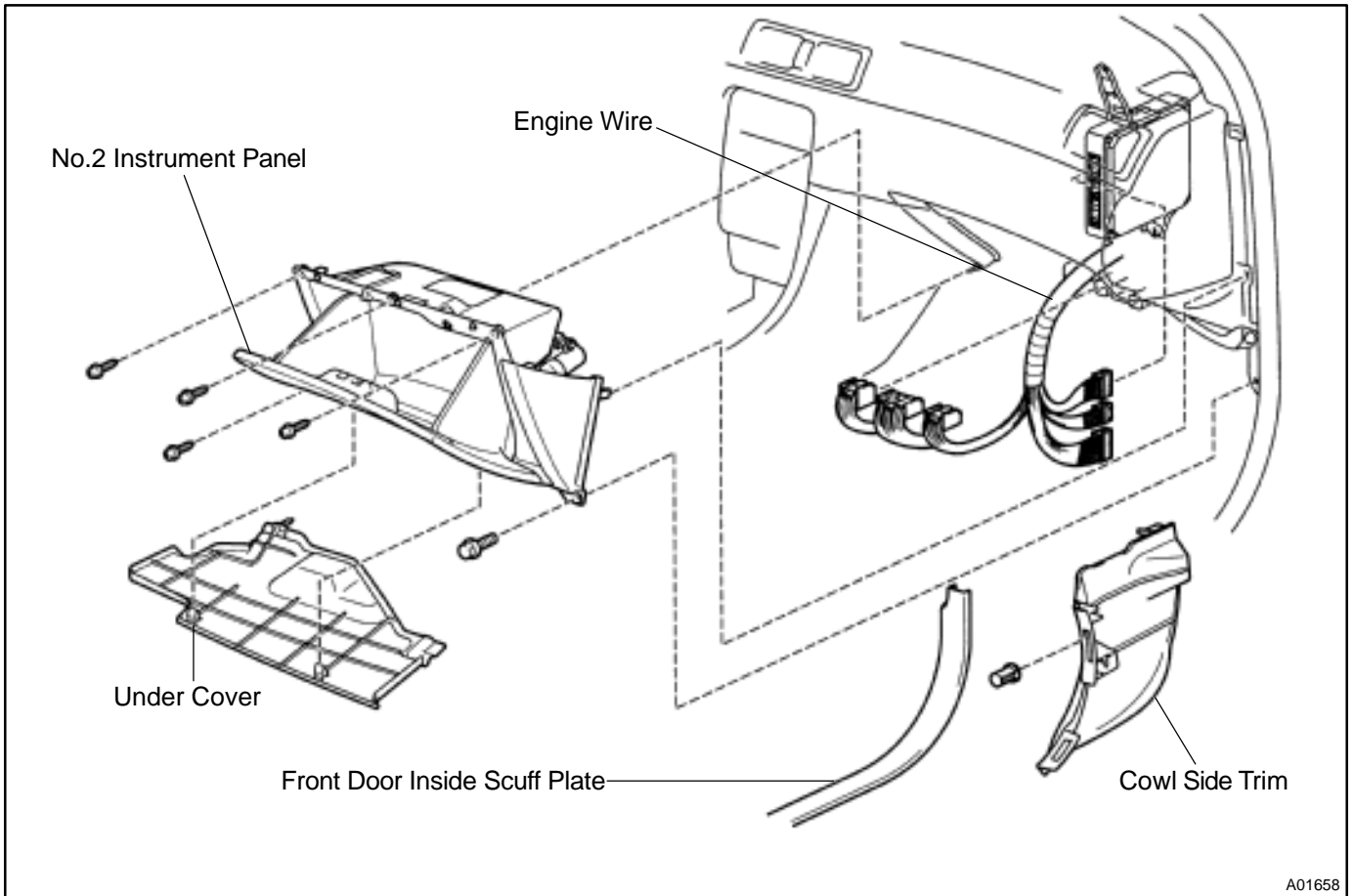

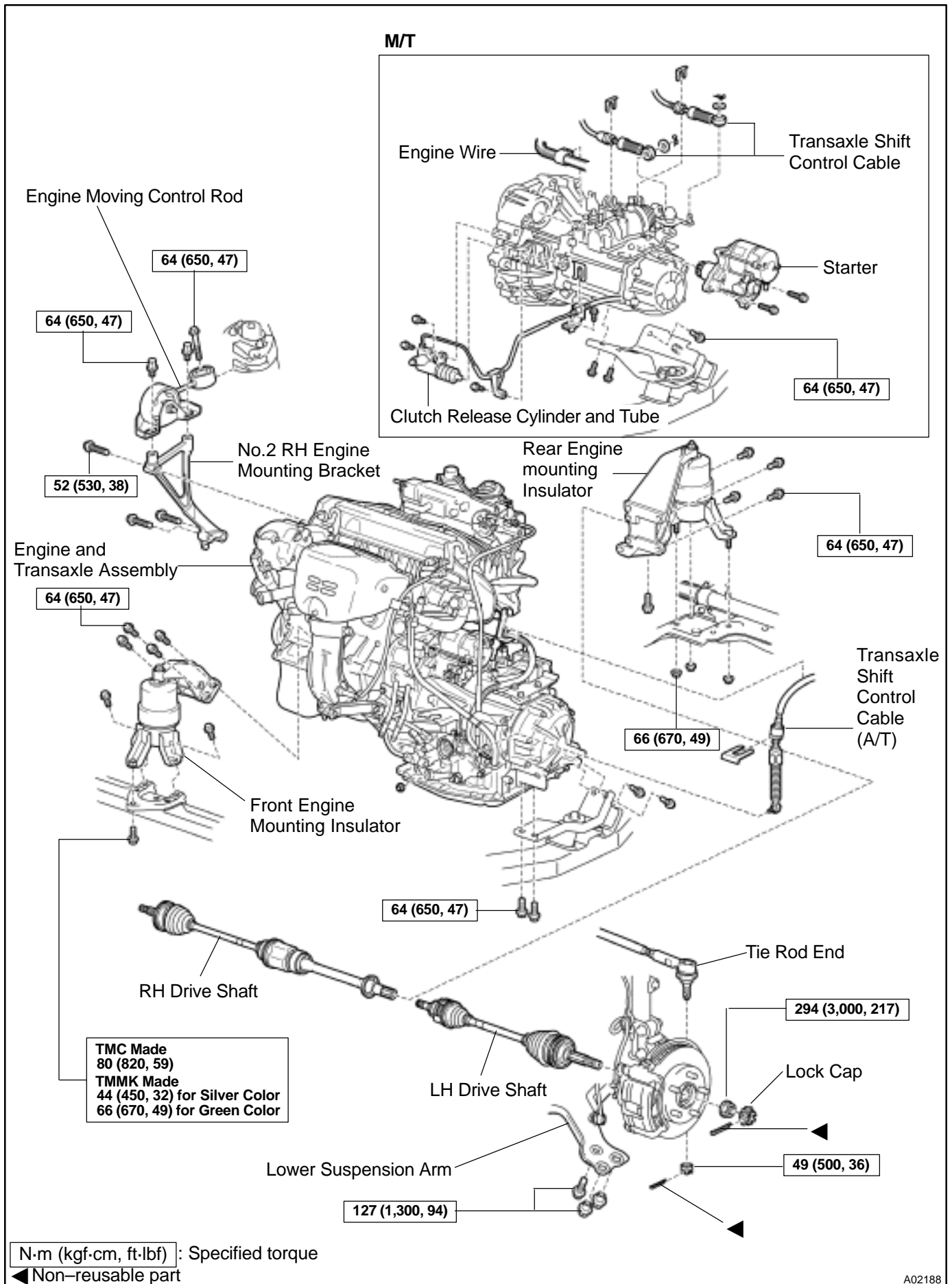

M/T

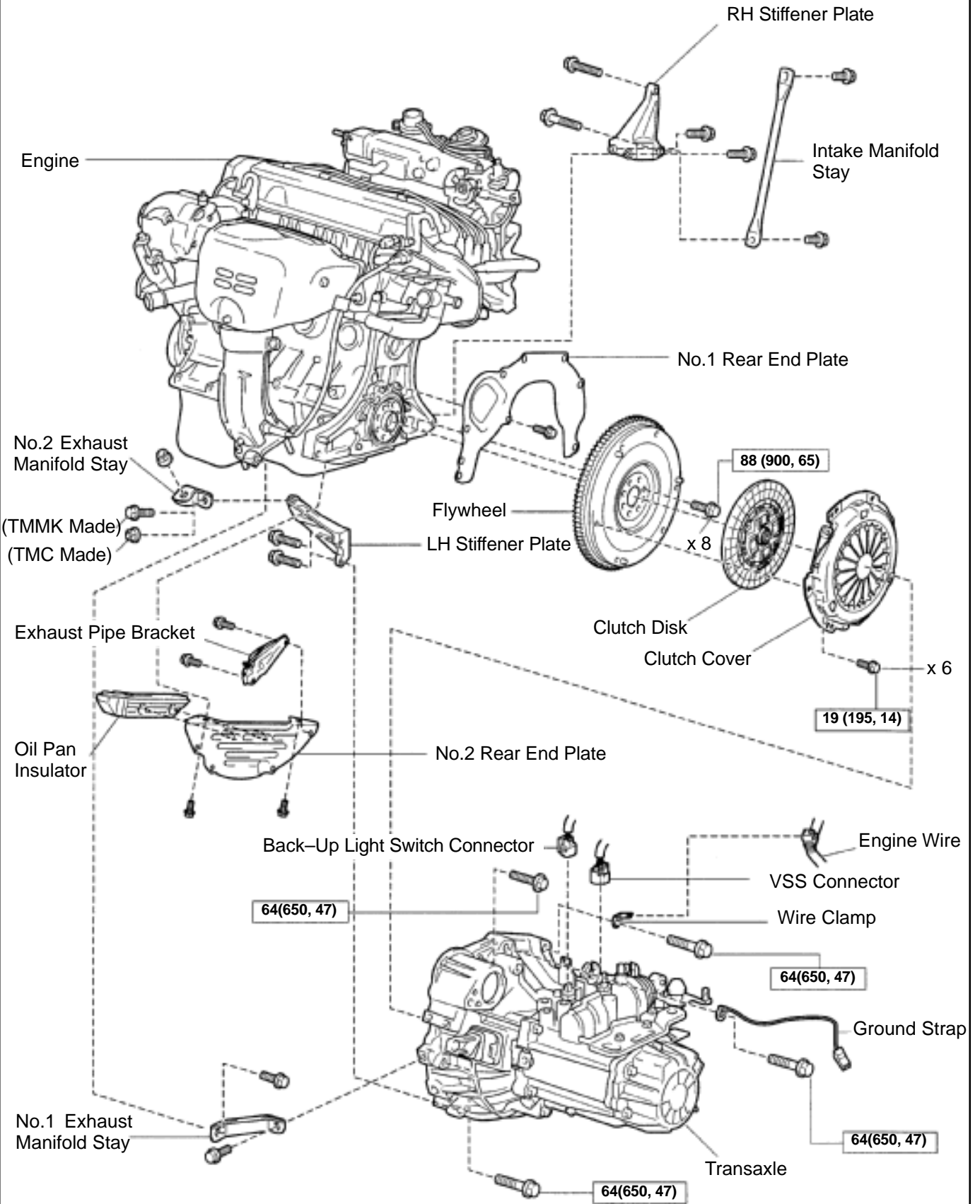

N·m (kgf·cm, ft·lbf) : Specified torque
 Precoated part

S05316

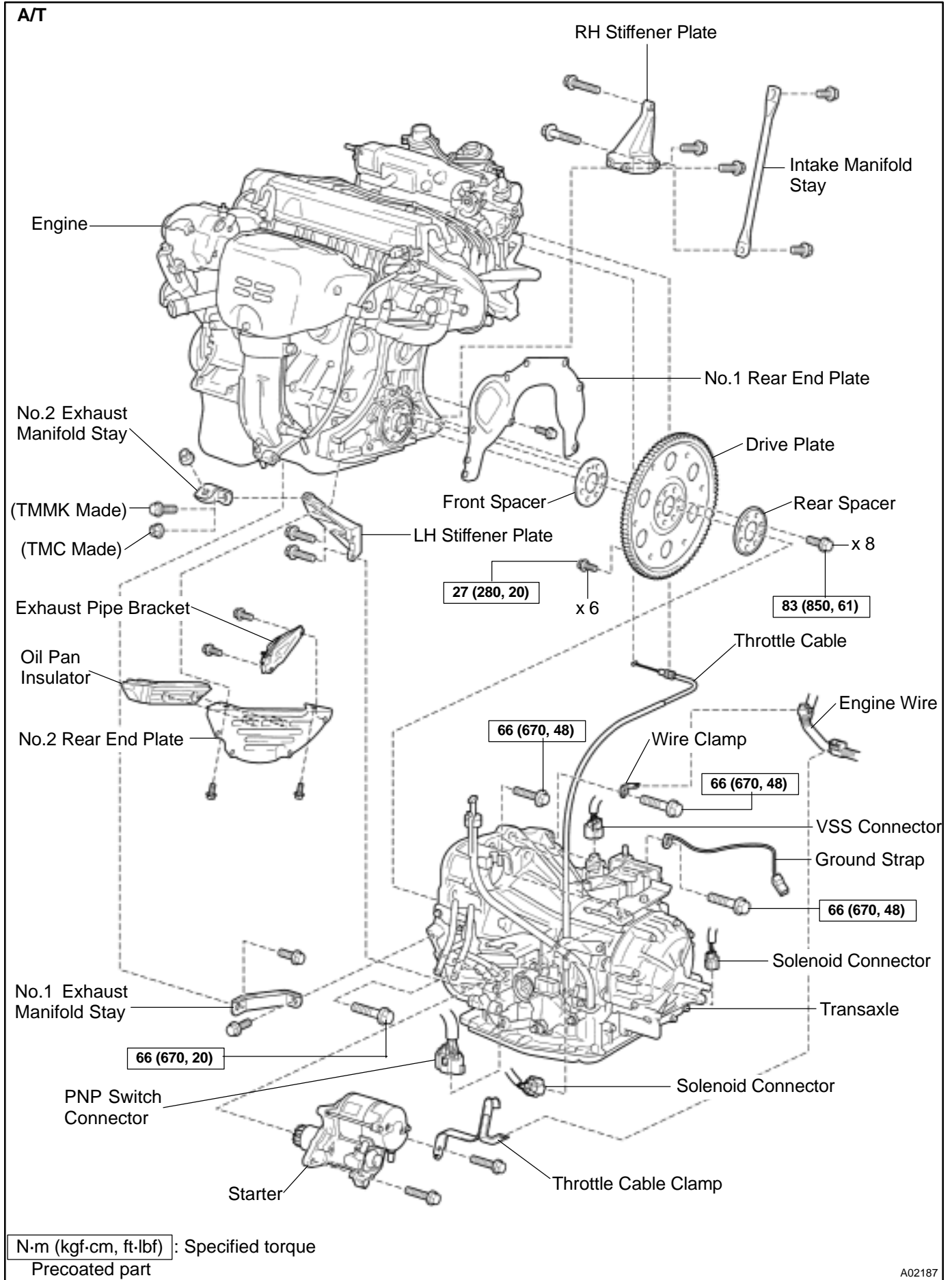

REMOVAL

1. **REMOVE HOOD**
2. **REMOVE FRONT FENDER APRON SEALS**
3. **DRAIN ENGINE COOLANT**
4. **DRAIN ENGINE OIL**
5. **DISCONNECT ACCELERATOR CABLE**
6. **REMOVE AIR CLEANER CAP**
 - (a) Disconnect the IAT sensor connector.
 - (b) Disconnect the VSV connector for the EVAP
 - (c) Disconnect the PCV hose from the cylinder head cover.
 - (d) Disconnect the EVAP hose from the throttle body.
 - (e) Disconnect the EVAP hose from the VSV.
 - (f) Disconnect the 2 clamps, and disconnect the air cleaner cap from the air cleaner case.
 - (g) Loosen hose clamp, and disconnect the air cleaner hose from the throttle body.
 - (h) Remove the air cleaner cap and hose assembly.
7. **REMOVE AIR CLEANER CASE**
 - (a) Remove the air filter.
 - (b) Remove the 3 bolts and air cleaner case.
8. **REMOVE BATTERY AND TRAY**
9. **REMOVE CRUISE CONTROL ACTUATOR**
10. **REMOVE RADIATOR (See page CO-18)**

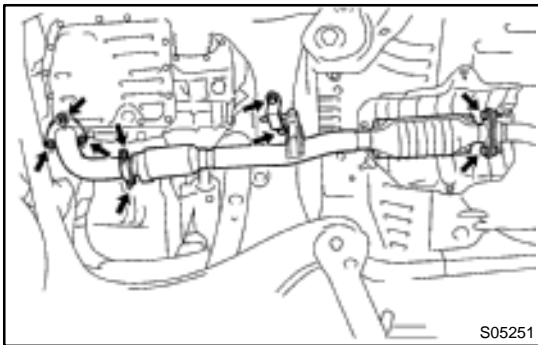

11. **REMOVE FRONT EXHAUST PIPE**
 - (a) Remove the 2 bolts holding the support stay to the support bracket.
 - (b) Remove the 2 bolts holding the support bracket to the front frame.
 - (c) Remove the 2 bolts and 2 nuts holding the front exhaust pipe to the center exhaust pipe.
 - (d) Remove the 3 nuts holding the front exhaust pipe to the exhaust manifold.
 - (e) Remove the front exhaust pipe and 2 gaskets.
 - (f) Remove the nut and support bracket.
12. **DISCONNECT CONNECTORS, WIRES, CABLES, CLAMPS AND HOSES**
 - (a) Disconnect the generator wire.
 - (b) Disconnect the generator connector.
 - (c) Disconnect the wire clamp from the generator.
 - (d) Disconnect the starter cable.
 - (e) Disconnect the starter connector.
 - (f) Disconnect the DLC1 from the bracket.

- (g) Disconnect the engine wire clamp from the bracket on the RH fender apron.
- (h) Disconnect the MAP sensor connector.
- (i) Disconnect the wire clamp from the bracket for the MAP sensor.
- (j) Disconnect the 2 ground strap connectors from the RH fender apron.
- (k) Disconnect the 2 ground strap connectors from the LH fender apron.
- (l) Disconnect the engine wire protector clamp from the battery bracket.
- (m) Disconnect the engine wire from the clamp on the fuel filter.
- (n) Disconnect the ground cable from the transaxle.
- (o) Disconnect the brake booster vacuum hose from the intake manifold.
- (p) Disconnect the heater hose from the water outlet.
- (q) Disconnect the heater hose from the water bypass pipe.
- (r) Disconnect the fuel inlet hose from the fuel filter.
- (s) Disconnect the MAP sensor vacuum hose from the gas filter on the intake manifold.

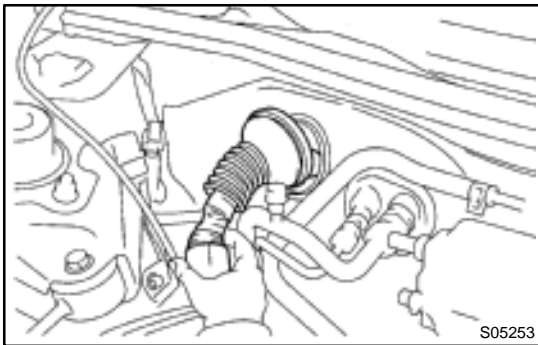

13. DISCONNECT ENGINE WIRE FROM CABIN

- (a) Remove the under cover.
- (b) Disconnect the 3 ECM connectors.
- (c) Disconnect the 3 cowl wire connectors from the connectors on the bracket.
- (d) Disconnect the grommet from the cowl panel, and pull out the engine wire.

14. REMOVE DRIVE SHAFTS (See page SA-17)

15. DISCONNECT TRANSAXLE CONTROL CABLE(S) FROM TRANSAXLE

16. M/T:

REMOVE STARTER (See page ST-5)

17. M/T:

DISCONNECT CLUTCH RELEASE CYLINDER AND TUBE FROM TRANSAXLE

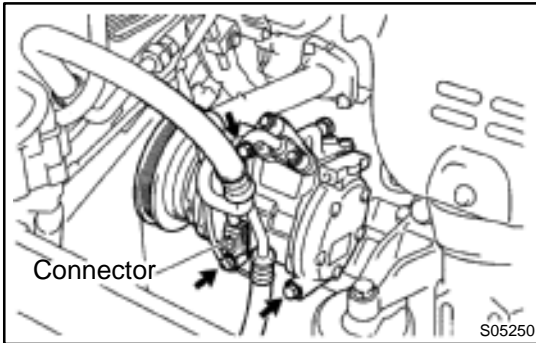

- 18. DISCONNECT A/C COMPRESSOR FROM ENGINE**
- Disconnect the A/C compressor connector.
 - Remove the drive belt.
 - Remove the 3 bolts, and disconnect the A/C compressor from the engine.
 - Remove the cylinder block insulator.

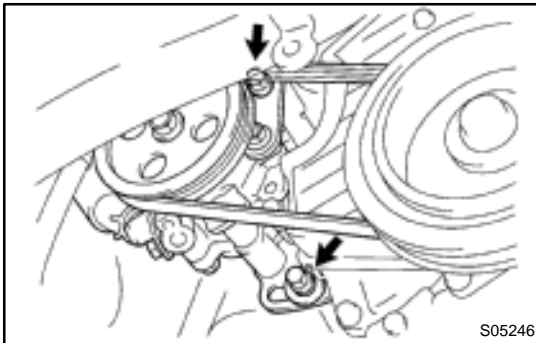

- 19. DISCONNECT PS PUMP FROM ENGINE**
- Disconnect the PS oil pressure switch connector.
 - Loosen the 2 bolts, and remove the drive belt.
 - Remove the 2 bolts, and disconnect the PS pump from the engine.

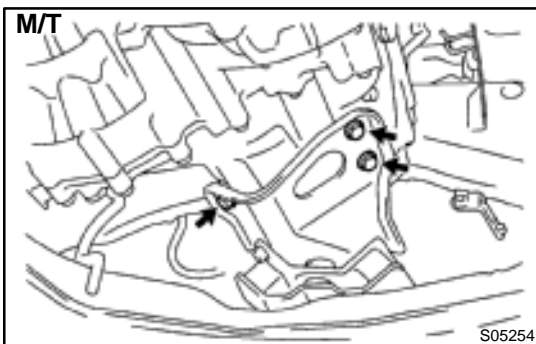

- 20. REMOVE BOLTS HOLDING TRANSAXLE TO LH ENGINE MOUNTING INSULATOR**

M/T:
Remove the 3 bolts.

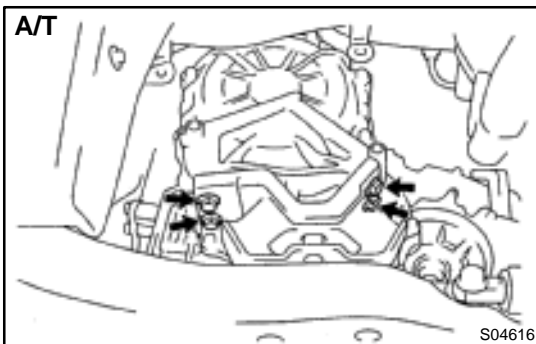

A/T:
Remove the 4 bolts.

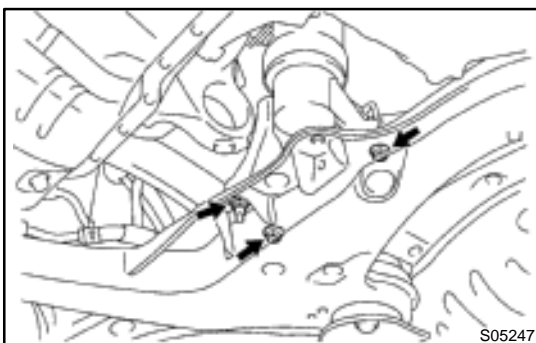

- 21. REMOVE NUTS HOLDING REAR ENGINE MOUNTING BRACKET TO FRONT FRAME**
- Remove the 2 hole plugs.
 - Remove the 3 nuts.

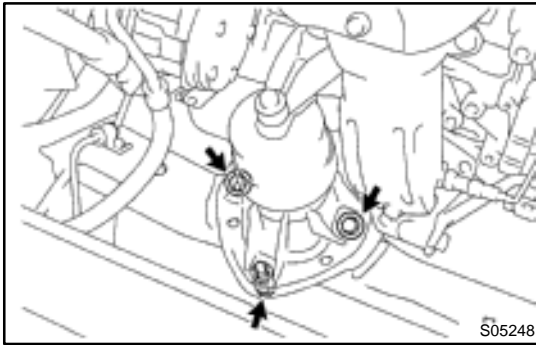

22. REMOVE BOLTS HOLDING FRONT ENGINE MOUNTING INSULATOR TO FRONT FRAME

Remove the 3 bolts.



23. ATTACH ENGINE SLING DEVICE TO ENGINE HANGERS

Attach the engine chain hoist to the engine hangers.

CAUTION:

Do not attempt to hang the engine by hooking the chain to any other part.

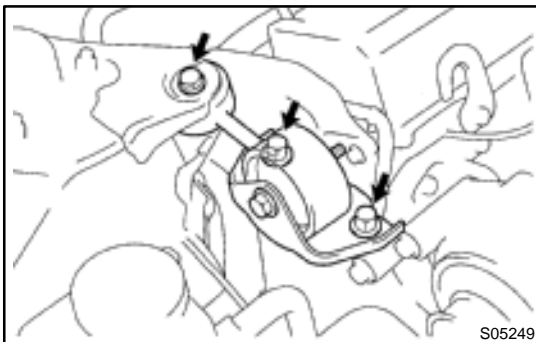

24. REMOVE ENGINE MOVING CONTROL ROD

Remove the 3 bolts and control rod.

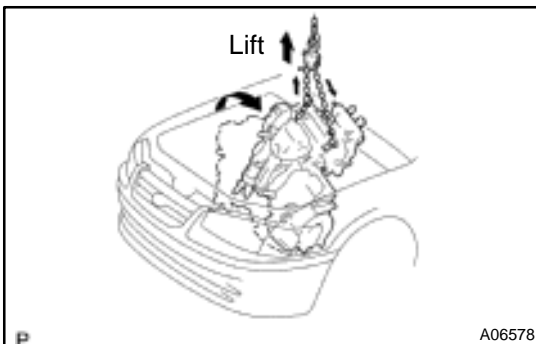

25. REMOVE ENGINE AND TRANSAXLE ASSEMBLY FROM VEHICLE

(a) Lift the engine out of the vehicle slowly and carefully.

NOTICE:

Make sure the engine is clear of all wiring, hoses and cables.

(b) Place the engine and transaxle assembly onto the stand.

26. REMOVE FRONT ENGINE MOUNTING INSULATOR FROM ENGINE

Remove the 4 bolts and mounting insulator.

27. REMOVE REAR ENGINE MOUNTING INSULATOR FROM ENGINE

Remove the 4 bolts, the mounting insulator.

28. REMOVE NO.2 RH ENGINE MOUNTING BRACKET FROM ENGINE

Remove the 3 bolts and mounting bracket.

29. A/T:

DISCONNECT THROTTLE CABLE FROM THROTTLE BODY

30. **A/T:**
REMOVE STARTER (See page ST-5)
31. **DISCONNECT CONNECTORS**
- (a) Disconnect the VSS connector.
 - (b) **M/T:**
Disconnect the back-up light switch connector.
 - (c) **A/T:**
Disconnect the PNP switch connector.
 - (d) **A/T:**
Disconnect the 2 solenoid connectors.

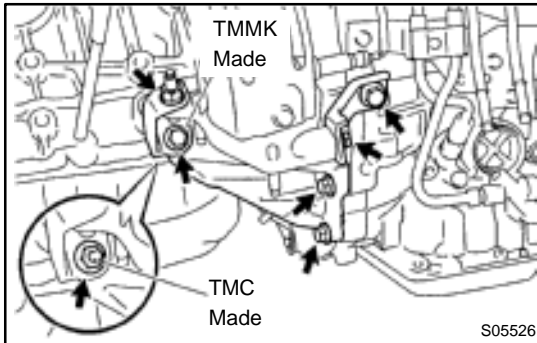

32. **REMOVE NO.1 EXHAUST MANIFOLD STAY**

Remove the 2 bolts and manifold stay.

33. **REMOVE NO.2 EXHAUST MANIFOLD STAY AND LH STIFFENER PLATE**

- (a) **TMC Made:**
Remove the 2 nuts and manifold stay.
- (b) **TMMK Made:**
Remove the bolt, nut and manifold stay.
- (c) Remove the 2 bolts and stiffener plate.

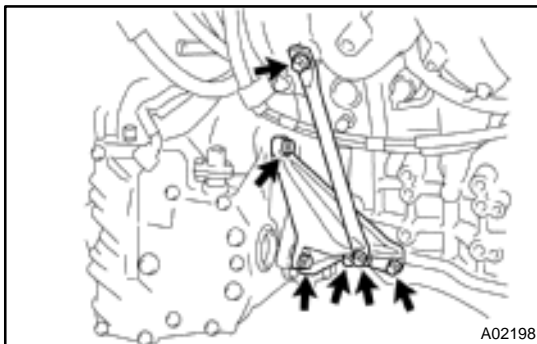

34. **REMOVE INTAKE MANIFOLD STAY**

Remove the 2 bolts and intake manifold stay.

35. **REMOVE RH STIFFENER PLATE**

Remove the 4 bolts and stiffener plate.

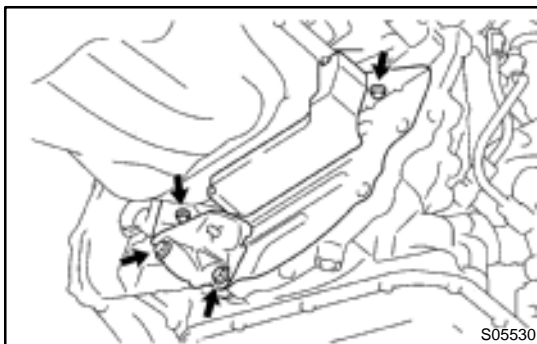

36. **REMOVE EXHAUST PIPE BRACKET, OIL PAN INSULATOR AND NO.2 REAR END PLATE**

- (a) Remove the 2 bolts and exhaust pipe bracket.
- (b) Remove the 2 bolts, oil pan insulator and rear end plate.

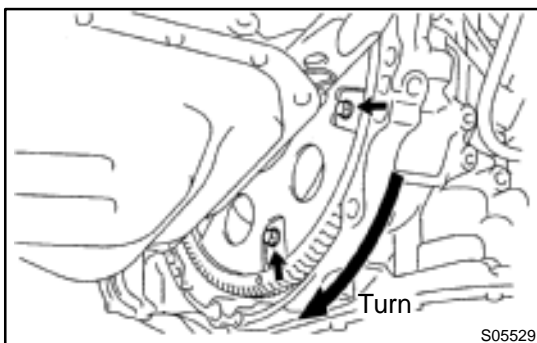

37. **A/T:**

REMOVE TORQUE CONVERTER CLUTCH BOLTS

- (a) Turn the crankshaft pulley bolt to gain access to each bolt.
- (b) Hold the crankshaft pulley bolt with a wrench, and remove the 6 bolts.

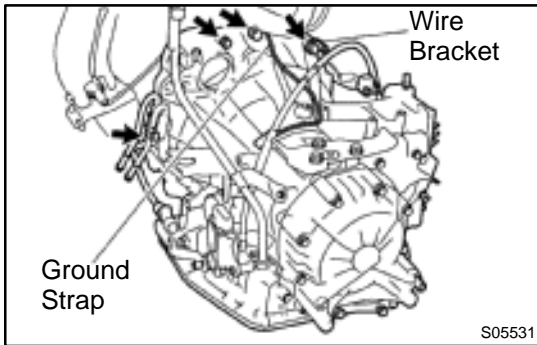
**38. REMOVE TRANSAXLE**

- (a) Remove the 4 bolts, ground strap and wire bracket.
- (b) Remove the transaxle together with the torque converter clutch (A/T) from the engine.

39. M/T:**REMOVE CLUTCH COVER AND DISC****40. M/T:****REMOVE FLYWHEEL**

Remove the 8 bolts and flywheel.

41. A/T:**REMOVE DRIVE PLATE**

Remove the 8 bolts, front spacer, drive plate and rear spacer.

42. REMOVE NO.1 REAR END PLATE

Remove the bolt and end plate.

INSTALLATION

1. INSTALL NO.1 REAR END PLATE

Install the end plate with the bolt.

Torque: 9.3 N·m (95 kgf·cm, 82 in.-lbf)

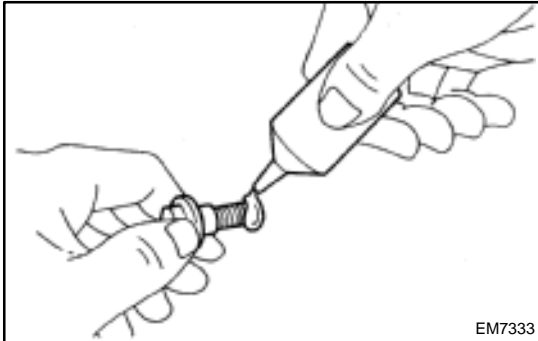

2. M/T: INSTALL FLYWHEEL

(a) Apply adhesive to 2 or 3 threads of the bolt end.

Adhesive:

Part No. 08833-00070, THREE BOND 1324 or equivalent

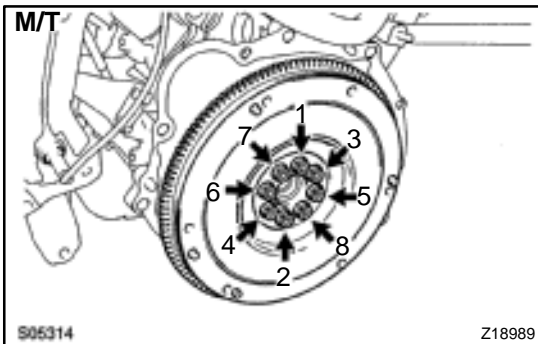

(b) Install the flywheel on the crankshaft.

(c) Install and uniformly tighten the 8 bolts in several passes, in the sequence shown.

Torque: 88 N·m (900 kgf·cm, 65 ft·lbf)

3. A/T: INSTALL DRIVE PLATE (See step 2)

Torque: 83 N·m (850 kgf·cm, 61 ft·lbf)

4. M/T: INSTALL CLUTCH DISC AND COVER

5. A/T: CHECK TORQUE CONVERTER CLUTCH INSTALLATION (A140E: See page AX-25)

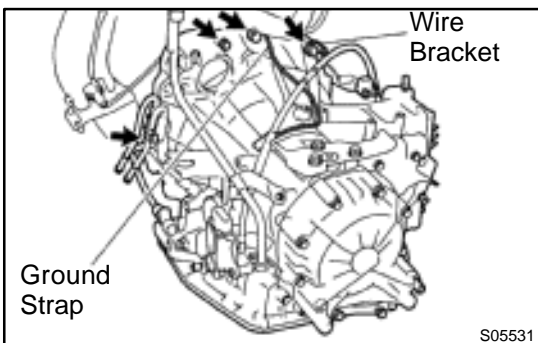

6. INSTALL TRANSAXLE TO ENGINE

(a) Attach the transaxle to the engine.

(b) Install the ground strap, wire bracket and 4 bolts.

Torque:

46 N·m (470 kgf·cm, 34 ft·lbf) for 14 mm head

64 N·m (650 kgf·cm, 47 ft·lbf) for 17 mm head

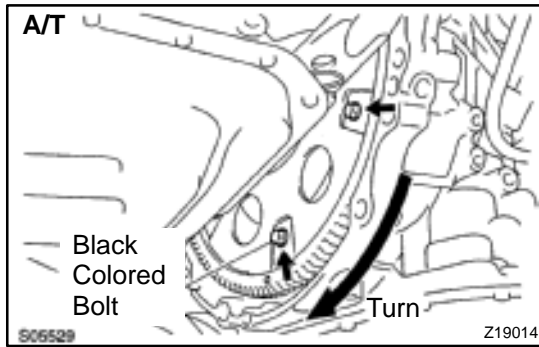

7. A/T:

INSTALL TORQUE CONVERTER CLUTCH BOLTS

- (a) Apply adhesive to 2 or 3 threads of the bolt end.

Adhesive:

Part No. 08833-00070, THREE BOND 1324 or equivalent

- (b) Hold the crankshaft pulley bolt with a wrench, and install the 6 bolts evenly.

Torque: 27 N·m (280 kgf·cm, 20 ft·lbf)

HINT:

First tighten the black colored bolt, install the other bolts.

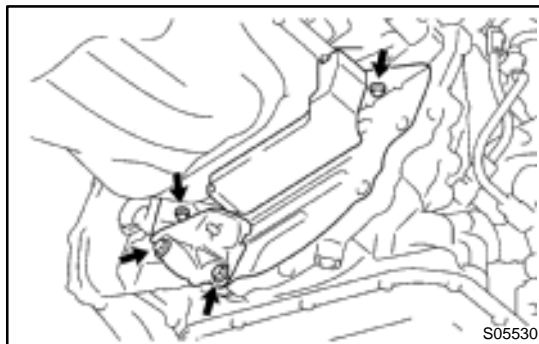

8. INSTALL NO.2 REAR END PLATE, OIL PAN INSULATOR AND EXHAUST PIPE BRACKET

- (a) Install the oil pan insulator to the rear end plate.
 (b) Install the rear end plate and exhaust pipe bracket with the 4 bolts.

Torque:

9.3 N·m (95 kgf·cm, 82 in.-lbf) for 10 mm head

19 N·m (195 kgf·cm, 14 ft·lbf) for 12 mm head

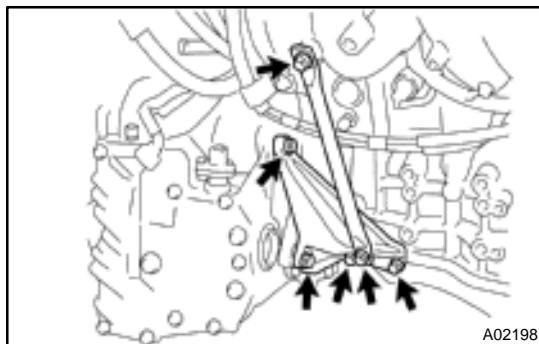

9. INSTALL RH STIFFENER PLATE

Install the stiffener plate with the 4 bolts.

Torque: 39 N·m (398 kgf·cm, 29 ft·lbf)

10. INSTALL INTAKE MANIFOLD STAY

Install the manifold stay with the 2 bolts.

Torque: 39 N·m (398 kgf·cm, 29 ft·lbf)

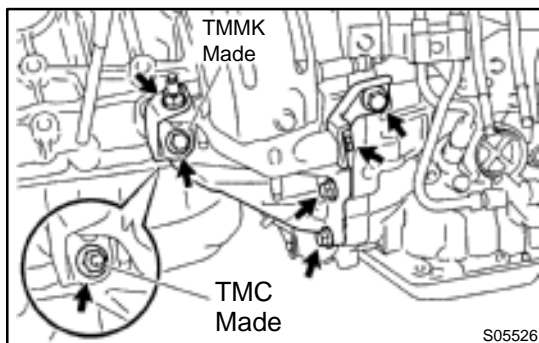

11. INSTALL LH STIFFENER PLATE AND NO.2 EXHAUST MANIFOLD STAY

- (a) TMC Made:

Temporarily install the stiffener plate and manifold stay with the 2 bolts and 2 nuts.

- (b) TMMK Made:

Temporarily install the stiffener plate and manifold stay with the 3 bolts and nut.

- (c) Tighten the 2 bolts holding the stiffener plate to the trans-axle.

Torque:**37 N·m (380 kgf-cm, 27 ft-lbf) for M/T****42 N·m (430 kgf-cm, 31 ft-lbf) for A/T**

(d) TMC Made:

Tighten the nut holding the manifold stay to the cylinder block.

Torque: 58 N·m (591 kgf-cm, 43 ft-lbf)

(e) TMMK Made:

Tighten the bolt holding the manifold stay to the cylinder block.

Torque: 42 N·m (425 kgf-cm, 31 ft-lbf)

(f) Tighten the nut holding the manifold stay to the exhaust manifold.

Torque: 42 N·m (425 kgf-cm, 31 ft-lbf)**12. INSTALL NO.1 EXHAUST MANIFOLD STAY**

Install the manifold stay with the 2 bolts.

Torque: 42 N·m (425 kgf-cm, 31 ft-lbf)**13. CONNECT CONNECTORS**

(a) Connect the VSS connector.

(b) M/T:

Connect the back-up light switch connector.

(c) A/T:

Connect the PNP switch connector.

(d) A/T:

Connect the 2 solenoid connectors.

14. A/T:**INSTALL STARTER (See page ST-19)****15. A/T:****INSTALL THROTTLE CABLE TO THROTTLE BODY****16. INSTALL NO.2 RH ENGINE MOUNTING BRACKET TO ENGINE**

Install the mounting insulator with the 3 bolts.

Torque: 52 N·m (530 kgf-cm, 38 ft-lbf)**17. INSTALL REAR ENGINE MOUNTING INSULATOR TO ENGINE**

Install the mounting insulator with the 4 bolts.

Torque: 64 N·m (650 kgf-cm, 47 ft-lbf)**18. INSTALL FRONT ENGINE MOUNTING INSULATOR TO ENGINE**

Install the mounting insulator with the 4 bolts.

Torque: 64 N·m (650 kgf-cm, 47 ft-lbf)

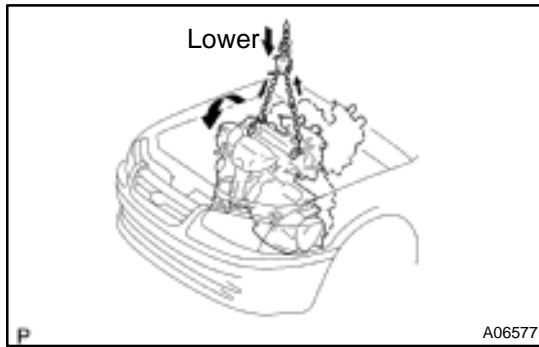

19. INSTALL ENGINE AND TRANSAXLE ASSEMBLY IN VEHICLE

- (a) Attach the engine sling device to the engine hangers.
- (b) Lower the engine into the engine compartment.
Tilt the transaxle downward, and lower the engine.
- (c) Keep the engine level, and attach front and rear mountings to the front frame.

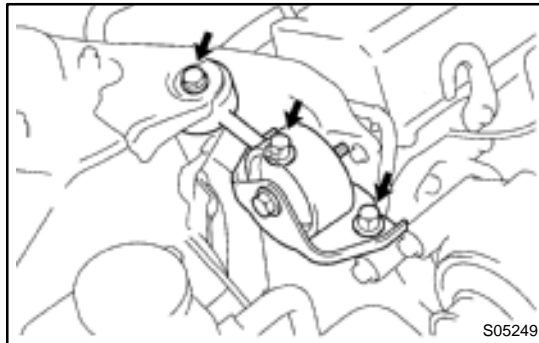

20. INSTALL ENGINE MOVING CONTROL ROD

Install the control rod with the 3 bolts.

Torque: 64 N·m (650 kgf·cm, 47 ft·lbf)

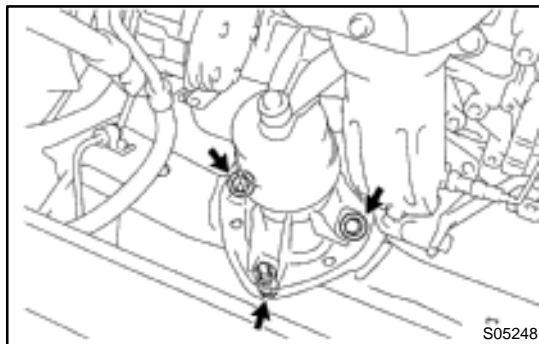

21. INSTALL BOLTS HOLDING FRONT ENGINE MOUNTING INSULATOR TO FRONT FRAME

Install the 3 bolts.

Torque:

TMC made

80 N·m (820 kgf·cm, 59 ft·lbf)

TMMK made

44 N·m (450 kgf·cm, 32 ft·lbf) for silver color

66 N·m (670 kgf·cm, 49 ft·lbf) for green color

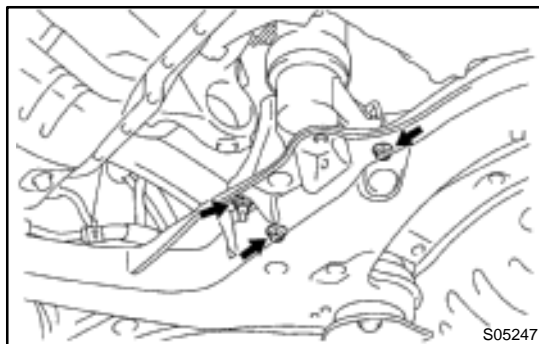

22. INSTALL NUTS HOLDING REAR ENGINE MOUNTING INSULATOR TO FRONT FRAME

- (a) Install the 3 nuts.

Torque: 66 N·m (670 kgf·cm, 49 ft·lbf)

- (b) Install the 2 hole plugs.

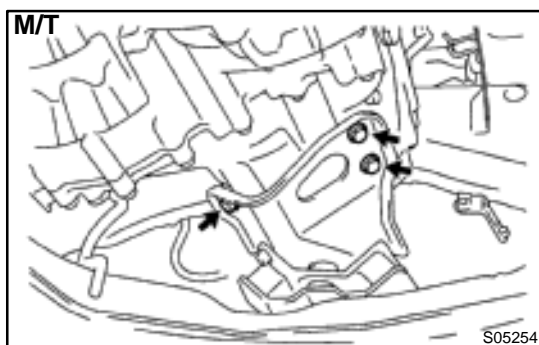

23. INSTALL BOLTS HOLDING LH ENGINE MOUNTING INSULATOR TO FRONT FRAME

M/T:

Install the 3 bolts.

Torque: 64 N·m (650 kgf·cm, 47 ft·lbf)

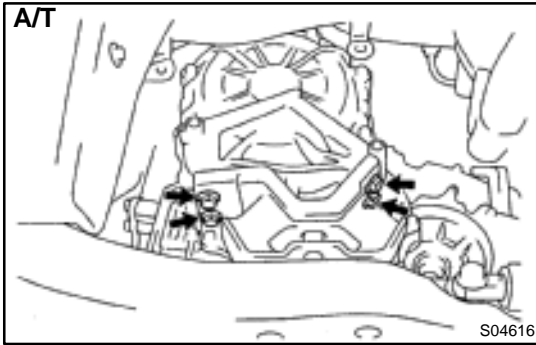

A/T:

Install the 4 bolts.

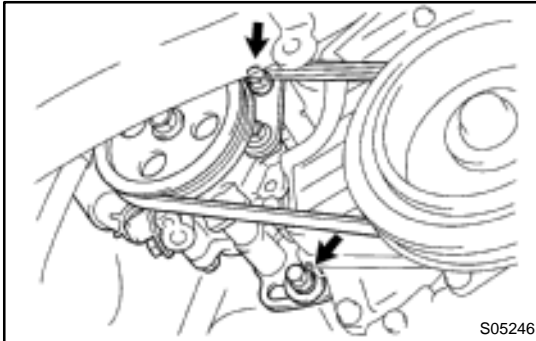
Torque: 64 N·m (650 kgf·cm, 47 ft·lbf)**24. REMOVE ENGINE SLING DEVICE****25. CONNECT TRANSAXLE CONTROL CABLE(S) TO TRANSAXLE****26. INSTALL PS PUMP**

(a) Install the PS pump with the 2 bolts.

Torque: 43 N·m (440 kgf·cm, 32 ft·lbf)

(b) Install the drive belt.

(c) Connect the PS oil pressure switch connector.

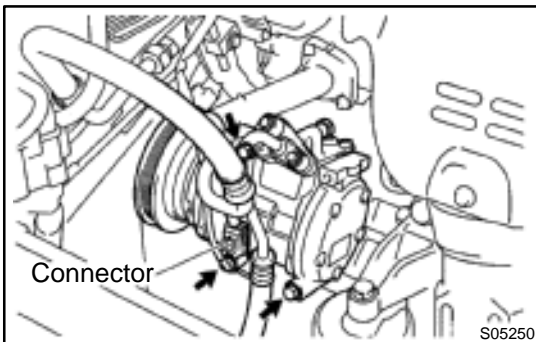
**27. INSTALL A/C COMPRESSOR**

(a) Install the cylinder block insulator and A/C compressor with the 3 bolts.

Torque: 25.5 N·m (260 kgf·cm, 19 ft·lbf)

(b) Install the drive belt.

(c) Connect the A/C compressor connector.

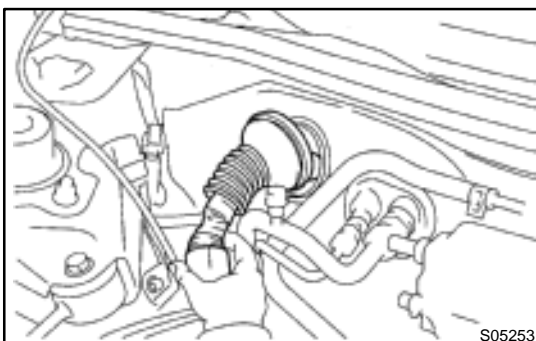
28. M/T:**INSTALL CLUTCH RELEASE CYLINDER AND TUBE TO TRANSAXLE****29. M/T:****INSTALL STARTER (See page ST-19)****30. INSTALL DRIVE SHAFTS (See page SA-24)****31. CONNECT ENGINE WIRE TO CABIN**

(a) Push in the engine wire through the cowl panel. Install the grommet.

(b) Connect the 3 engine ECM connectors.

(c) Connect the 3 cowl wire connectors to the connectors on the bracket.

(d) Install the under cover.

32. CONNECT CONNECTORS, WIRES, CABLES, CLAMPS AND HOSES

(a) Connect the generator wire.

- (b) Connect the generator connector.
 - (c) Install the wire clamp to the generator.
 - (d) Connect the starter cable.
 - (e) Connect the starter connector.
 - (f) Install the DLC1 to the bracket.
 - (g) Install the engine wire clamp to the bracket on the RH fender apron.
 - (h) Connect the MAP sensor connector.
 - (i) Install the wire clamp to the bracket for the MAP sensor.
 - (j) Connect the VSV connector for the vapor pressure sensor.
 - (k) Connect the 2 ground strap connectors to the RH fender apron.
 - (l) Connect the 2 ground strap connectors to the LH fender apron.
 - (m) Install the engine wire protector clamp to the battery bracket.
 - (n) Install the engine wire to the clamp on the fuel filter.
 - (o) Connect the ground cable to the transaxle.
 - (p) Connect the brake booster vacuum hose to the intake manifold.
 - (q) Connect the heater hose to the water outlet.
 - (r) Connect the heater hose to the water bypass pipe.
 - (s) Connect the fuel inlet hose to the fuel filter with 2 new gaskets and the union bolt.
- Torque: 29 N·m (300 kgf·cm, 21 ft·lbf)**
- (t) Connect the MAP sensor vacuum hose to the gas filter on the intake manifold.

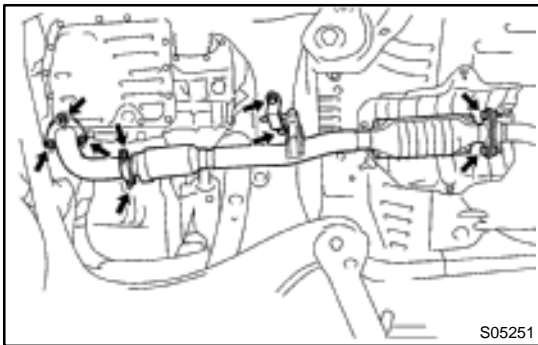

33. INSTALL FRONT EXHAUST PIPE

- (a) Install the support bracket with the nut.
Torque: 33 N·m (330 kgf·cm, 24 ft·lbf)
 - (b) Temporarily install 2 new gaskets and the front exhaust pipe with the 2 bolts and 5 nuts.
 - (c) Tighten the 3 nuts holding the exhaust manifold to the front exhaust pipe.
Torque: 62 N·m (630 kgf·cm, 46 ft·lbf)
 - (d) Tighten the 2 bolts and 2 nuts holding the front exhaust pipe to the center exhaust pipe.
Torque: 56 N·m (570 kgf·cm, 41 ft·lbf)
 - (e) Install the bracket with the 2 bolts.
Torque: 33 N·m (330 kgf·cm, 24 ft·lbf)
 - (f) Install the support stay with the 2 bolts.
Torque: 33 N·m (330 kgf·cm, 24 ft·lbf)
- 34. INSTALL RADIATOR (See page CO-23)**
- 35. INSTALL CRUISE CONTROL ACTUATOR**
- 36. INSTALL BATTERY TRAY AND BATTERY**
- 37. INSTALL AIR CLEANER CASE**
- Install the air cleaner case with the 3 bolts.

38. INSTALL AIR CLEANER CAP

- (a) Connect the air cleaner hose to the throttle body.
- (b) Attach the air cleaner cap to the air cleaner case, and install the 2 clamps.
- (c) Tighten the air cleaner hose clamp.
- (d) Connect the PCV hose to the cylinder head cover.
- (e) Connect the EVAP hose to the throttle body.
- (f) Connect the EVAP hose to the VSV.
- (g) Connect the IAT sensor connector.
- (h) Connect the VSV connector for the EVAP.

39. CONNECT ACCELERATOR CABLE**40. INSTALL ENGINE FENDER APRON SEALS****41. INSTALL HOOD****42. FILL ENGINE WITH OIL****43. FILL WITH ENGINE COOLANT****44. START ENGINE AND CHECK FOR LEAKS****45. RECHECK ENGINE COOLANT AND OIL LEVELS**

CYLINDER BLOCK COMPONENTS

EM08H-03

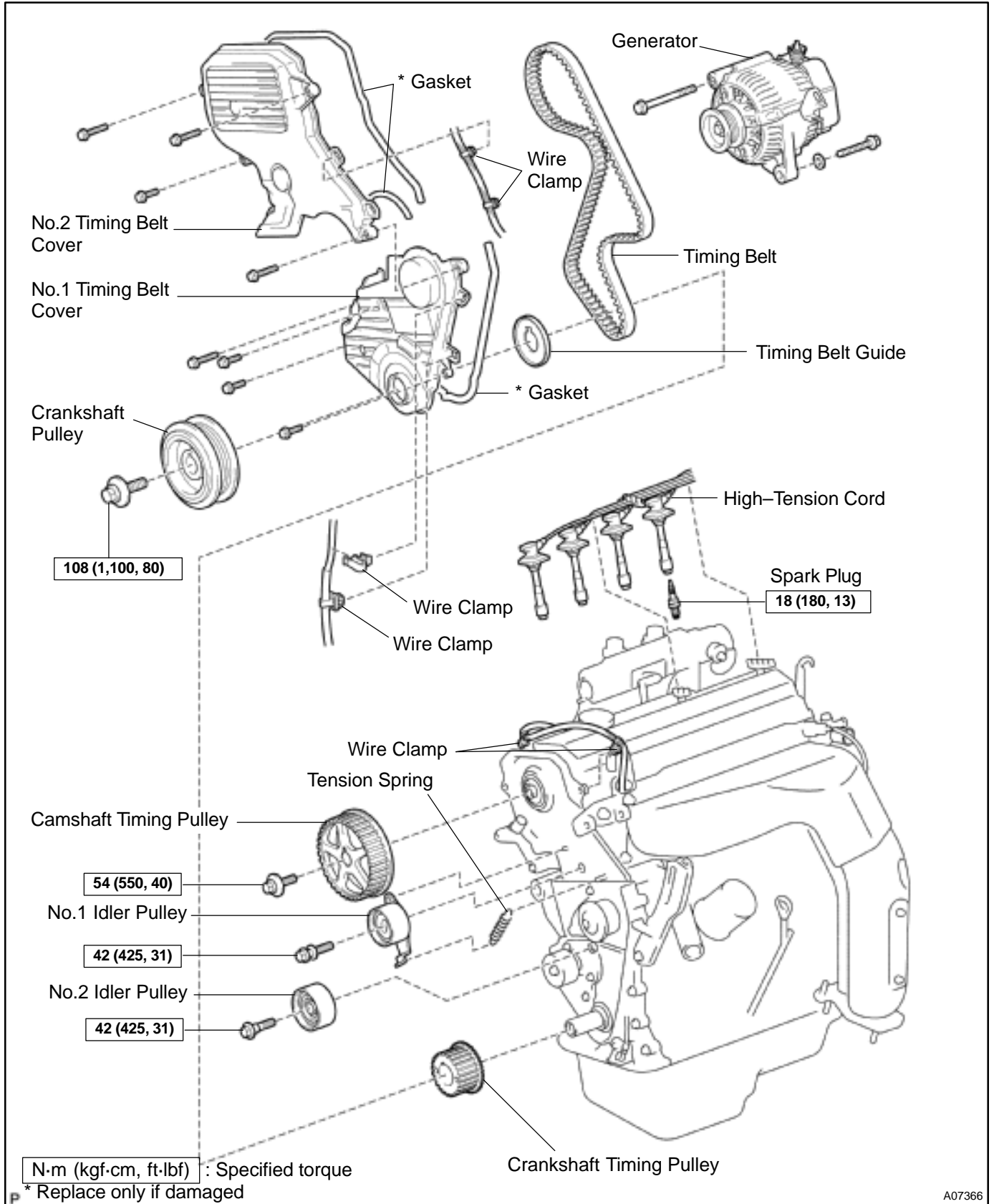

A07366

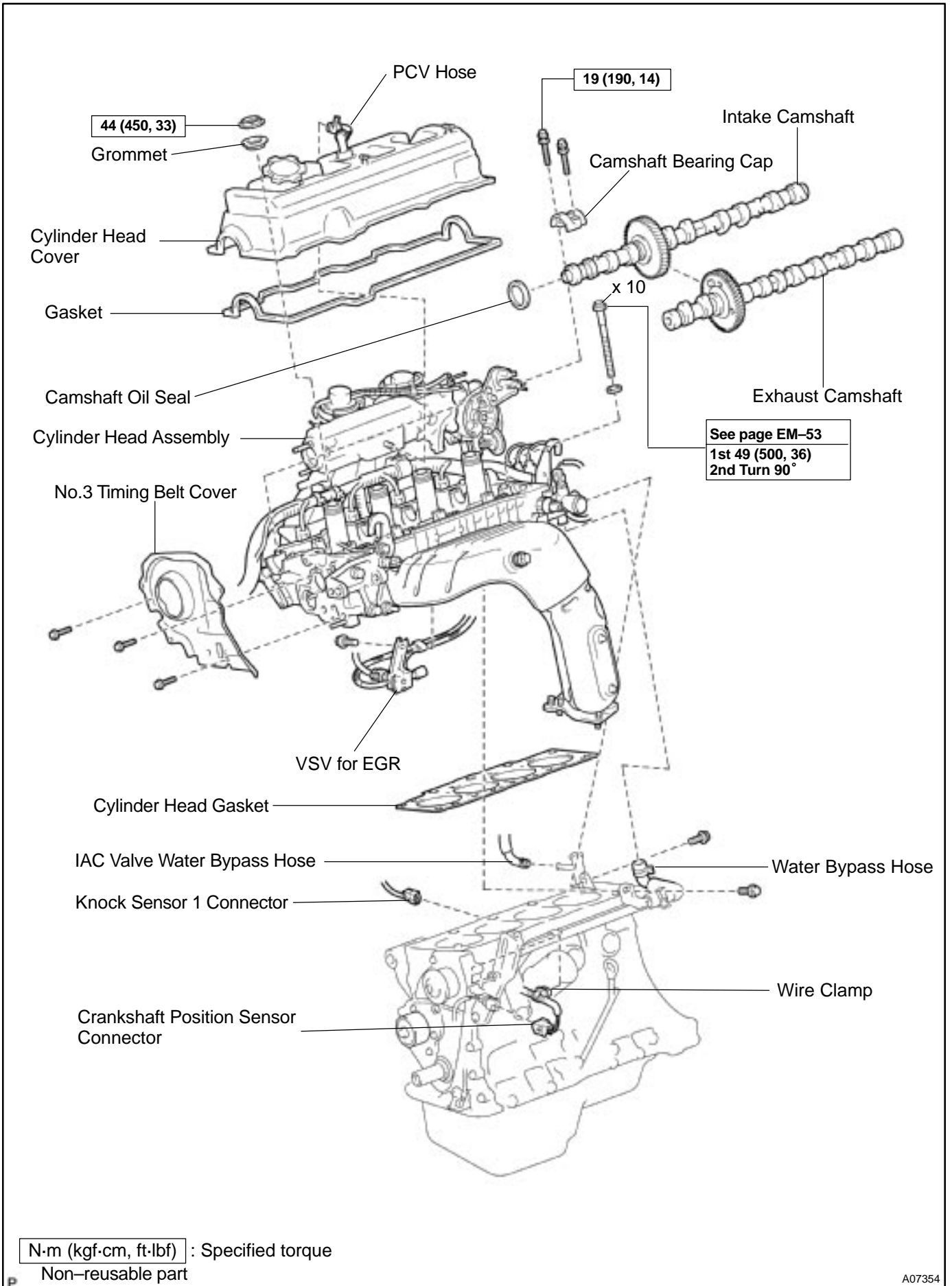

N·m (kgf·cm, ft·lbf) : Specified torque
 Non-reusable part

A07354

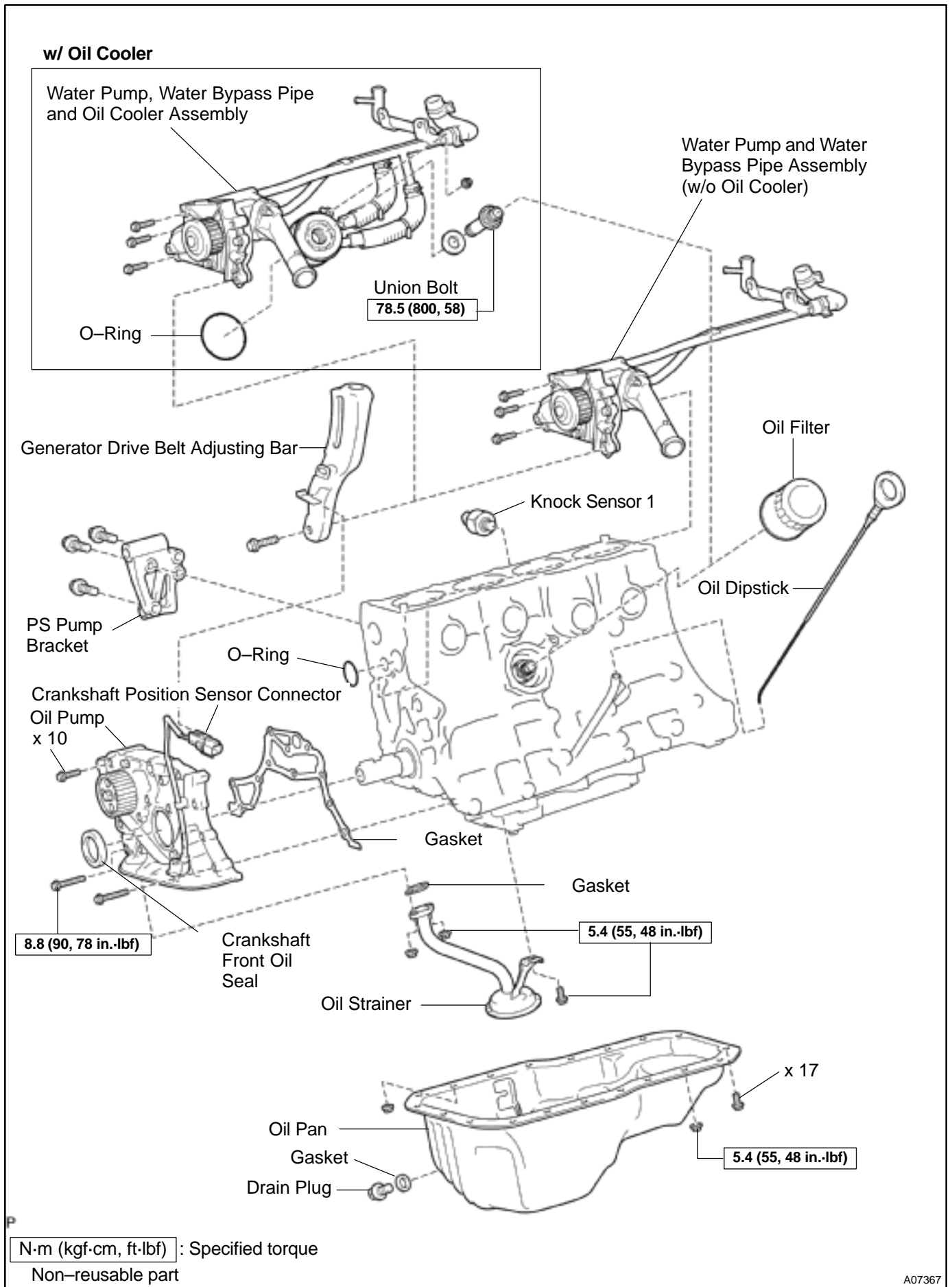

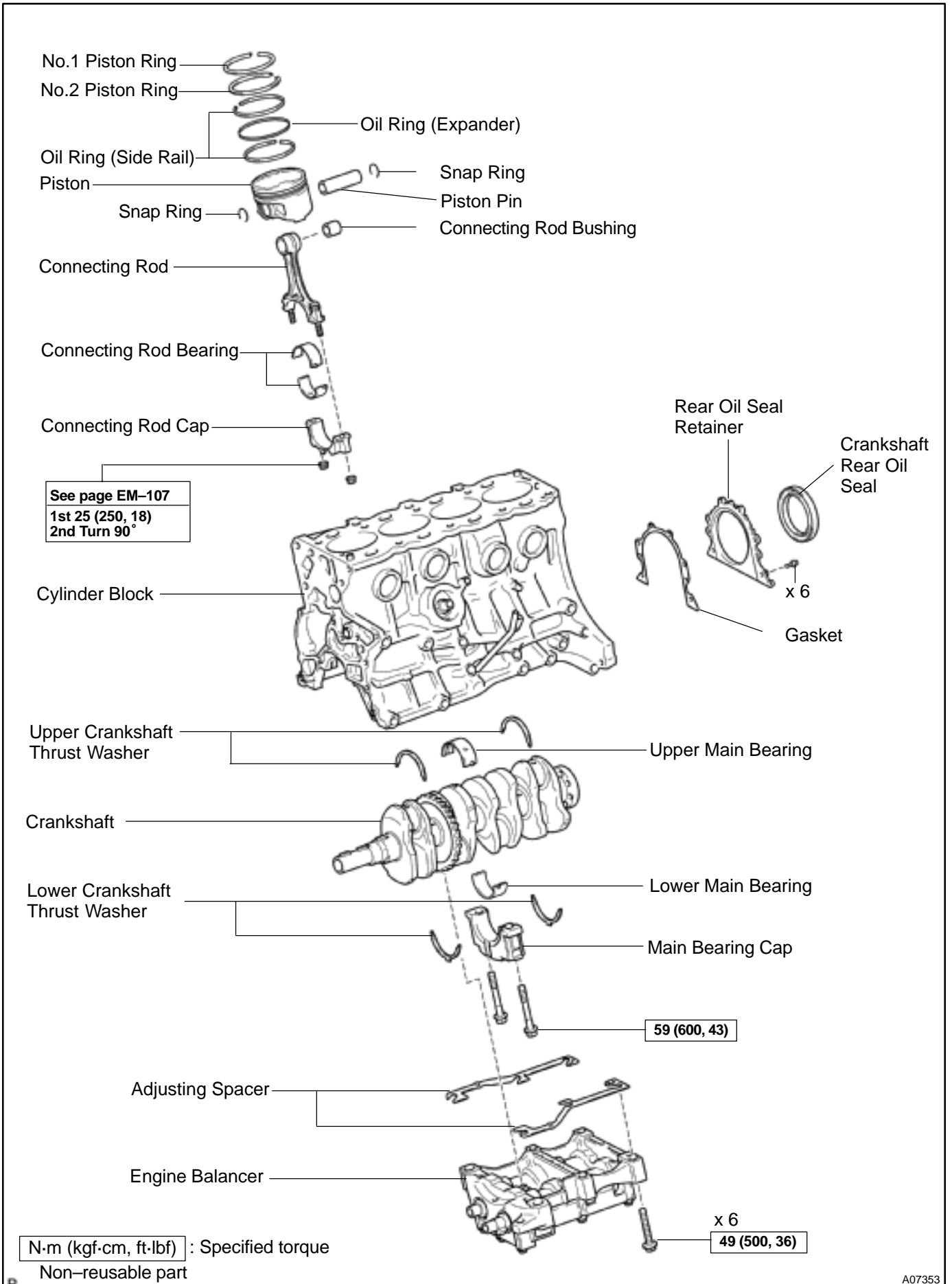

N·m (kgf·cm, ft·lbf) : Specified torque
 Non-reusable part

A07353

DISASSEMBLY

1. **INSTALL ENGINE TO ENGINE STAND FOR DISASSEMBLY**
2. **REMOVE TIMING BELT AND PULLEYS**
(See page EM-17)
3. **REMOVE CYLINDER HEAD ASSEMBLY**
 - (a) Remove the 3 bolts and No.3 timing belt cover.
 - (b) Remove the cylinder head cover.
 - (1) Disconnect the PCV hose from the intake manifold.
 - (2) Remove the 4 nuts, 4 grommets, head cover and gasket.
 - (c) Remove the camshafts. (See page EM-33)
 - (d) Disconnect the knock sensor 1 connector.
 - (e) Disconnect the crankshaft position sensor connector.
 - (f) Disconnect the wire clamp from the generator drive belt adjusting bar.
 - (g) Disconnect the IAC valve water bypass hose from the water bypass pipe.
 - (h) Disconnect the water bypass hose (from the water bypass pipe) from the water outlet.
 - (i) Remove the bolt holding the VSV for EGR to the intake manifold.
 - (j) Remove the 2 bolts holding the water bypass pipe to the cylinder head.
 - (k) Remove the cylinder head assembly.
(See page EM-33)
4. **REMOVE OIL DIPSTICK**
5. **REMOVE OIL PAN AND OIL PUMP**
 - (a) Disconnect the crankshaft position sensor connector from the generator drive belt adjusting bar.
 - (b) Remove the oil pan and oil pump. (See page LU-7)
6. **REMOVE PS PUMP BRACKET**
Remove the 3 bolts and pump bracket.
7. **REMOVE KNOCK SENSOR 1 (See page SF-57)**
8. **REMOVE OIL FILTER (See page LU-2)**

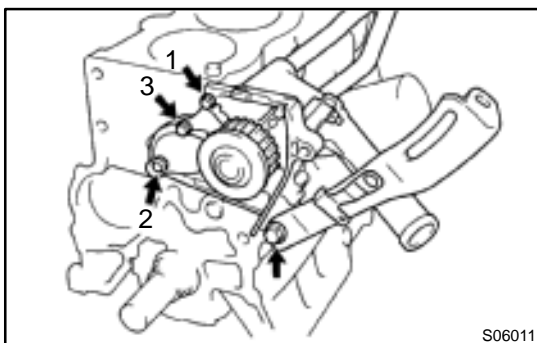

S06011

9. **REMOVE WATER PUMP, WATER BYPASS PIPE AND OIL COOLER (w/ OIL COOLER) ASSEMBLY**
 - (a) w/ Oil Cooler:
Remove the nut and union bolt, and disconnect the oil cooler. Remove the O-ring.
 - (b) Remove the bolt and generator drive belt adjusting bar.
 - (c) Remove the 3 bolts in the sequence shown, remove the water pump, water bypass pipe, oil cooler (w/ oil cooler) assembly and O-ring.

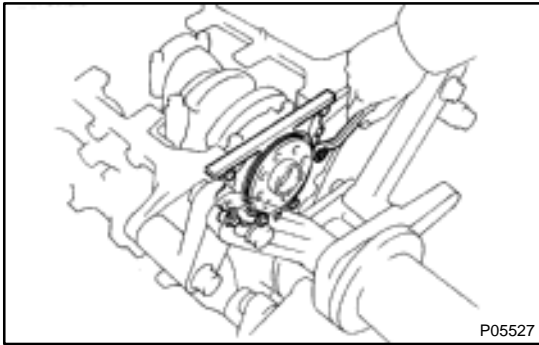

10. REMOVE REAR OIL SEAL RETAINER

Remove the 6 bolts, retainer and gasket.

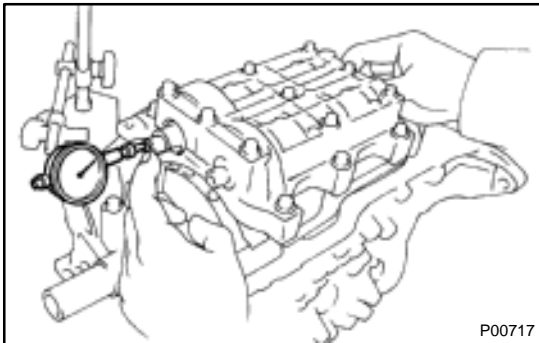

11. CHECK THRUST CLEARANCES OF NO.1 AND NO.2 BALANCE SHAFTS OF ENGINE BALANCER

Using a dial indicator, measure the thrust clearance while moving the balance shaft back and forth.

Standard thrust clearance:

0.060 – 0.110 mm (0.0024 – 0.0043 in.)

Maximum clearance: 0.11 mm (0.0043 in.)

If the clearance is greater than maximum, replace the balance shaft housings and bearings. If necessary, replace the balance shafts.

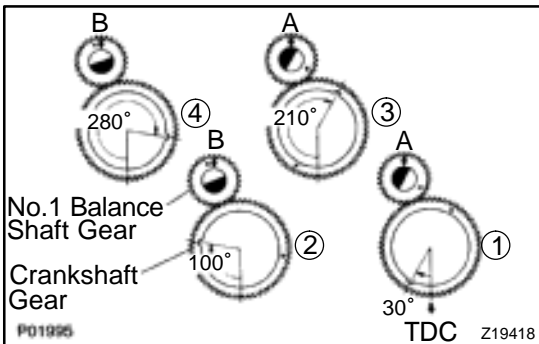

12. CHECK AND ADJUST BACKLASH OF CRANKSHAFT GEAR AND NO.1 BALANCE SHAFT GEAR

NOTICE:

Backlash between the crankshaft gear and No.1 balance shaft gear varies with the rotation of the balance shaft and the deviation of the crankshaft gear. Accordingly, it is necessary to measure the backlash at the 4 points shown in the illustration on the left.

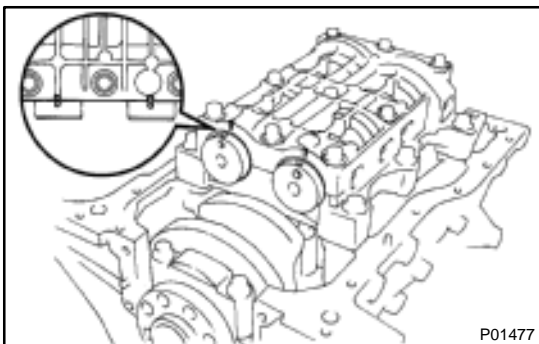

- (a) Turn the crankshaft 2 or 3 times to settle the crankshaft gear and No.1 balance shaft gear.
- (b) When the No.1 piston is at TDC, check that the punch marks shown in the illustration of the balance shafts are aligned with the grooves of the No.2 housing.

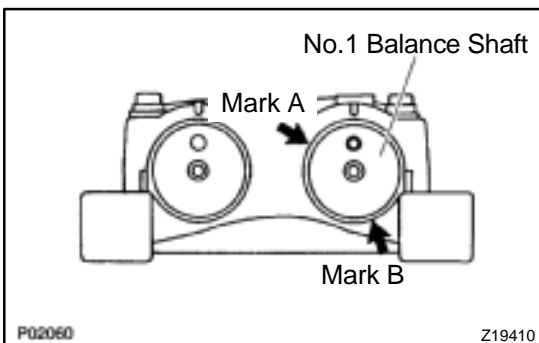

- (c) Check that punch marks A and B are at the positions on the No.1 balance shaft indicated in the illustration.

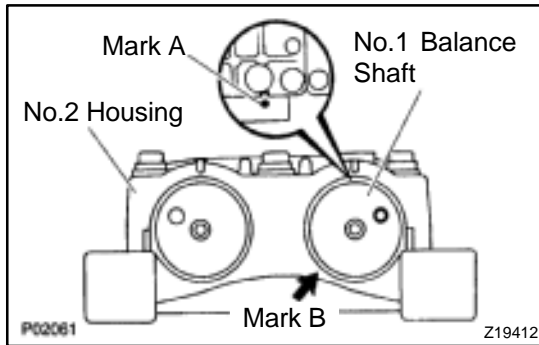

- (d) First turn the crankshaft clockwise, and align the groove of the No.2 balance shaft housing with punch mark A of the No.1 balance shaft.

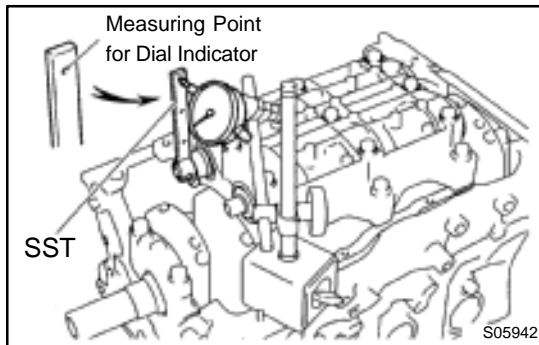

- (e) Set SST and a dial indicator as shown in the illustration.
SST 09224-74010

HINT:

Make sure that the needle of the dial indicator is perpendicular to the SST and that it is placed in the middle of the 3rd indentation.

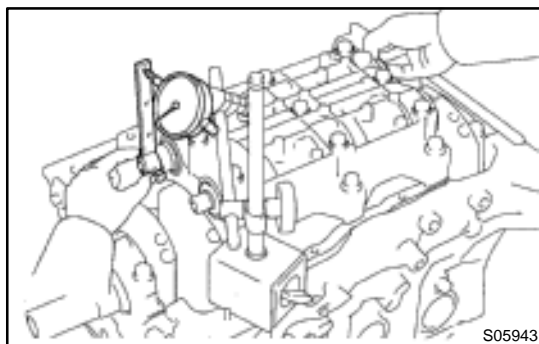

- (f) Lightly turn the No.1 balance shaft by hand and measure the backlash.

HINT:

Turn the No.1 balance shaft 4 or 5 times to provide a steady backlash reading.

To prevent excessive backlash due to thrust clearance, measure the backlash while pressing on the rear of the No.1 balance shaft.

Standard backlash (at punch mark A):
0.005 – 0.040 mm (0.0002 – 0.0016 in.)

NOTICE:

Do not turn the No.1 balance shaft strongly.

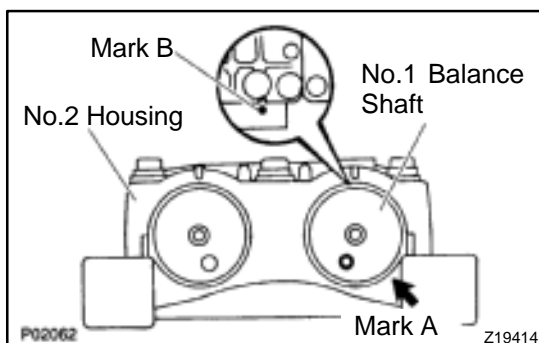

- (g) Remove the dial indicator and SST.
(h) Turn the crankshaft clockwise to align the groove of the No.2 housing with punch mark B.

(i) Set the dial indicator. (See step (e))

(j) Measure the backlash. (See step (f))

Standard backlash (at punch mark B):
0.005 – 0.060 mm (0.0002 – 0.0024 in.)

- (k) Remove the dial indicator.

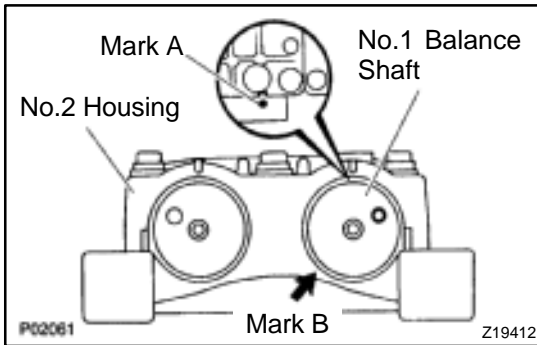

- (l) Turn the crankshaft clockwise again to align the groove of the No.2 housing with punch mark A.
- (m) Set the dial indicator. (See step (e))
- (n) Measure the backlash. (See step (f))
Standard backlash (at punch mark A):
0.005 – 0.040 mm (0.0002 – 0.0016 in.)
- (o) Remove the dial indicator.

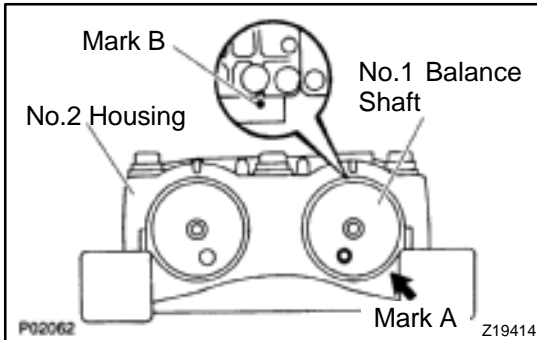

- (p) Turn the crankshaft clockwise again to align the groove of the No.2 housing with punch mark B.
- (q) Set the dial indicator. (See step (e))
- (r) Measure the backlash. (See step (f))
Standard backlash (at punch mark B):
0.005 – 0.060 mm (0.0002 – 0.0024 in.)
- (s) Remove the dial indicator.

If even one of the 4 points measured above exceeds the backlash specification, adjust the backlash with new spacers.

NOTICE:

Use the same size spacers for both the left and right sides.

HINT:

Varying the spacer thickness by 0.02 mm (0.0008 in.) change the backlash by about 0.014 mm (0.0006 in.).

If the backlash is greater than permitted maximum, select a thinner shim.

If the backlash is less than the specification, select a thicker shim.

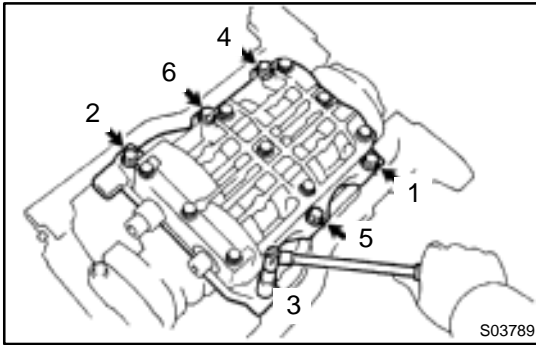
**13. REMOVE ENGINE BALANCER**

- (a) Uniformly loosen and remove the 6 bolts in several passes, in the sequence shown.
- (b) Remove the engine balancer and spacers.

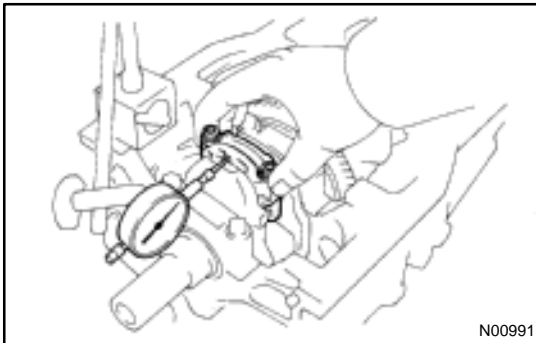
**14. CHECK CONNECTING ROD THRUST CLEARANCE**

Using a dial indicator, measure the thrust clearance while moving the connecting rod back and forth.

Standard thrust clearance:

0.160 – 0.312 mm (0.0063 – 0.0123 in.)

Maximum thrust clearance: 0.35 mm (0.0138 in.)

If the thrust clearance is greater than maximum, replace the connecting rod assembly. If necessary, replace the crankshaft.

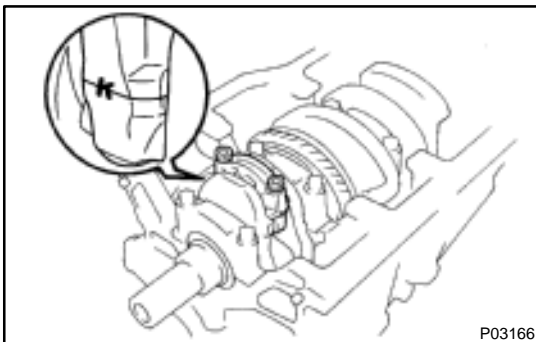
**15. REMOVE CONNECTING ROD CAPS AND CHECK OIL CLEARANCE**

- (a) Check the matchmarks on the connecting rod and cap to ensure correct reassembly.
- (b) Remove the 2 connecting rod cap nuts.

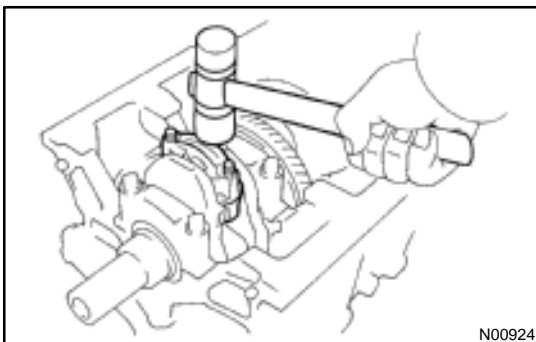

- (c) Using a plastic-faced hammer, lightly tap the connecting rod bolts and lift off the connecting rod cap.

HINT:

Keep the lower bearing inserted with the connecting rod cap.

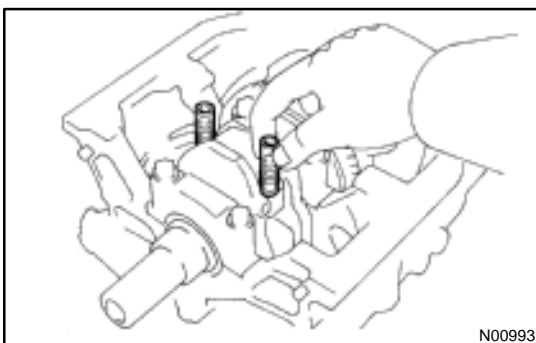

- (d) Cover the connecting rod bolts with a short piece of hose to protect the crankshaft from damage.
- (e) Clean the crank pin and bearing.
- (f) Check the crank pin and bearing for pitting and scratches. If the crank pin or bearing is damaged, replace the bearings. If necessary, grind or replace the crankshaft.

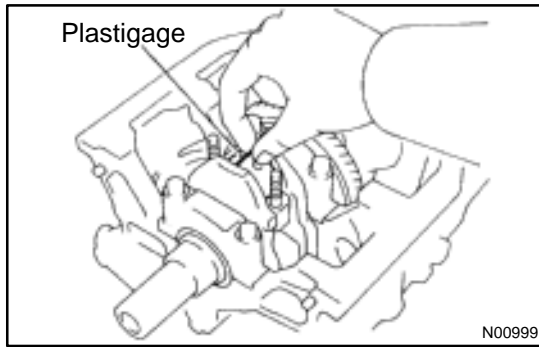

- (g) Lay a strip of Plastigage across the crank pin.

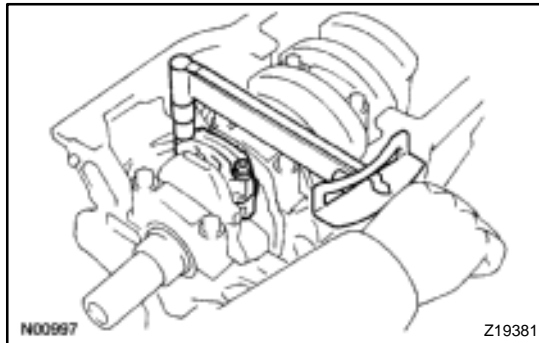

- (h) Install the connecting rod cap. (See page EM-107)

NOTICE:

Do not turn the crankshaft.

- (i) Remove the connecting rod cap.
(See steps (b) and (c))

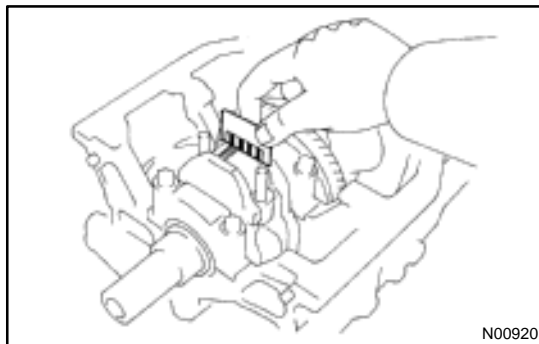

- (j) Measure the Plastigage at its widest point.

Standard oil clearance:

STD	0.024 – 0.055 mm (0.0009 – 0.0022 in.)
U/S 0.25	0.023 – 0.069 mm (0.0009 – 0.0027 in.)

Maximum oil clearance: 0.08 mm (0.0031 in.)

If the oil clearance is greater than maximum, replace the bearings. If necessary, grind or replace the crankshaft.

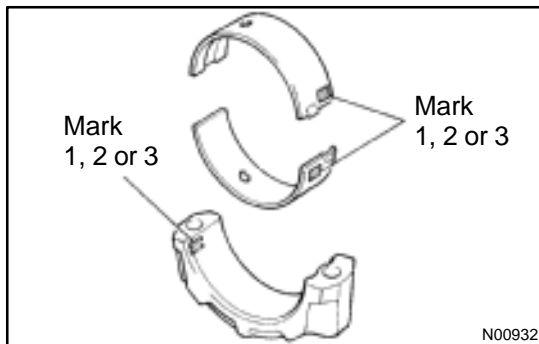

HINT:

If using a standard bearing, replace it with one having the same number marked on the connecting rod cap. There are 3 sizes of standard bearings, marked "1", "2" and "3" accordingly.

Reference

Standard sized bearing center wall thickness:

Mark "1"	1.484 – 1.488 mm (0.0584 – 0.0586 in.)
Mark "2"	1.488 – 1.492 mm (0.0586 – 0.0587 in.)
Mark "3"	1.492 – 1.496 mm (0.0587 – 0.0589 in.)

- (k) Completely remove the Plastigage.

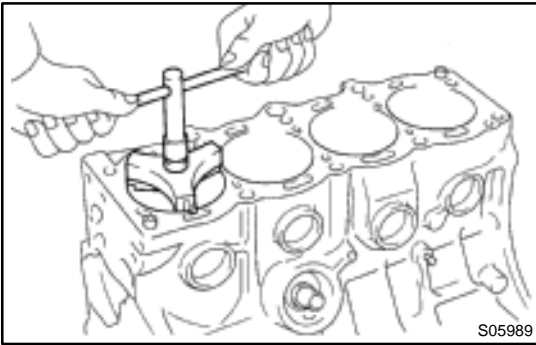

16. REMOVE PISTON AND CONNECTING ROD ASSEMBLIES

- (a) Using a ridge reamer, remove all the carbon from the top of the cylinder.

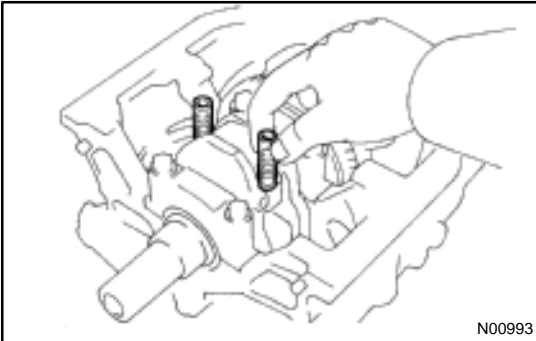

- (b) Cover the connecting rod bolts with a short piece of hose to protect the crankshaft from damage.
 (c) Push the piston, connecting rod assembly and upper bearing through the top of the cylinder block.

HINT:

Keep the bearings, connecting rod and cap together.
 Arrange the piston and connecting rod assemblies in the correct order.

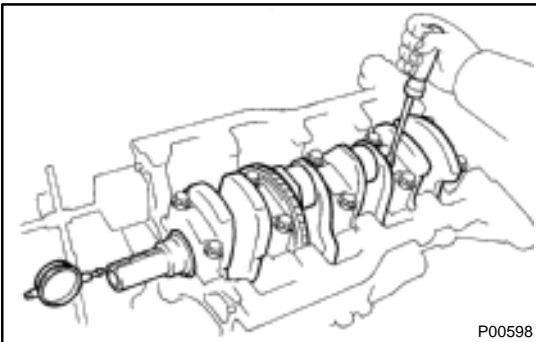

17. CHECK CRANKSHAFT THRUST CLEARANCE

Using a dial indicator, measure the thrust clearance while prying the crankshaft back and forth with a screwdriver.

Standard thrust clearance:

0.020 – 0.220 mm (0.0008 – 0.0087 in.)

Maximum thrust clearance: 0.30 mm (0.0118 in.)

If the thrust clearance is greater than maximum, replace the thrust washer as a set.

Thrust washer thickness:

2.440 – 2.490 mm (0.0961 – 0.0980 in.)

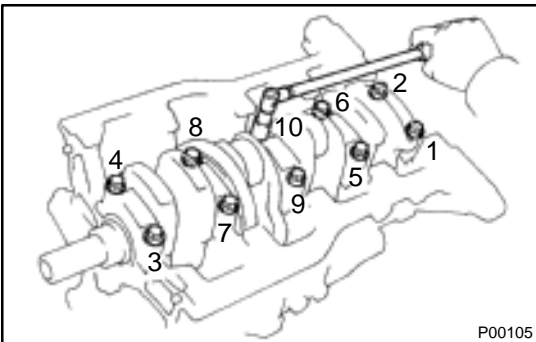

18. REMOVE MAIN BEARING CAPS AND CHECK OIL CLEARANCE

- (a) Uniformly loosen and remove the 10 main bearing cap bolts in several passes, in the sequence shown.

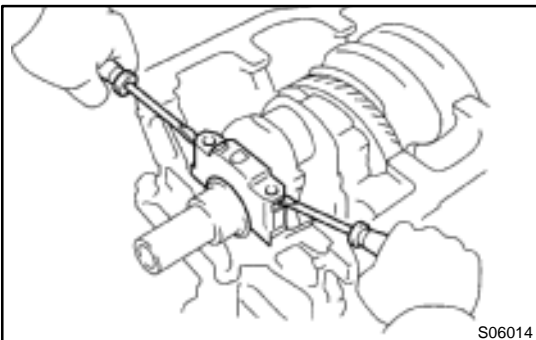

- (b) Using 2 screwdrivers, pry out the main bearing cap, and remove the 5 main bearing caps, 5 lower bearings and 2 lower thrust washers (No.3 main bearing cap only).

HINT:

Keep the lower bearing and main bearing cap together.
 Arrange the main bearing caps and lower thrust washers in the correct order.

- (c) Lift out the crankshaft.

HINT:

Keep the upper bearing and upper thrust washers together with the cylinder block.

- (d) Clean each main journal and bearing.
- (e) Check each main journal and bearing for pitting and scratches.

If the journal or bearing is damaged, replace the bearings. If necessary, grind or replace the crankshaft.

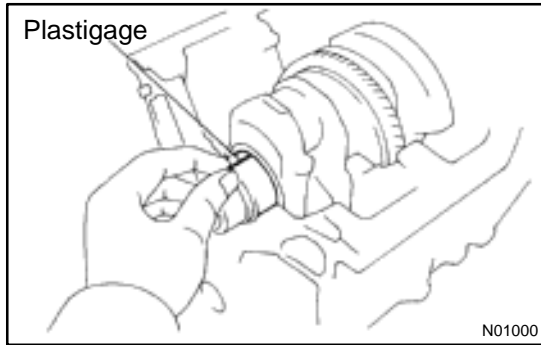

- (f) Place the crankshaft on the cylinder block.
- (g) Lay a strip of Plastigage across each journal.

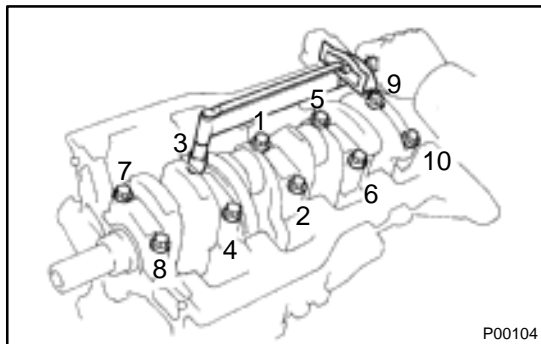

- (h) Install the main bearing caps. (See page EM-107)

NOTICE:

Do not turn the crankshaft.

- (i) Remove the main bearing caps. (See steps (a) and (b))

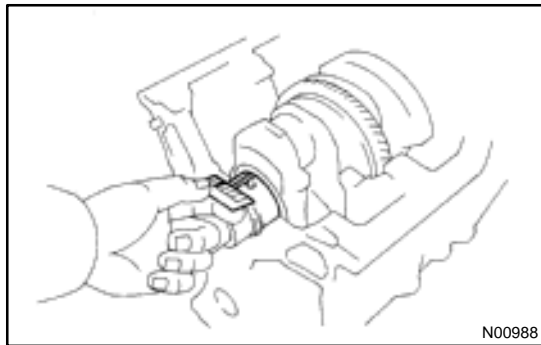

- (j) Measure the Plastigage at its widest point.

Standard clearance:

No.3	STD	0.025 – 0.044 mm (0.0010 – 0.0017 in.)
	U/S 0.25	0.027 – 0.067 mm (0.0011 – 0.0026 in.)
Others	STD	0.015 – 0.034 mm (0.0006 – 0.0013 in.)
	U/S 0.25	0.019 – 0.059 mm (0.0007 – 0.0023 in.)

Maximum clearance: 0.08 mm (0.0031 in.)

HINT:

If replacing the cylinder block subassembly, the bearing standard clearance will be:

No.3	0.027 – 0.054 mm (0.0001 – 0.0021 in.)
Others	0.017 – 0.044 mm (0.0007 – 0.0017 in.)

If the oil clearance is greater than maximum, replace the bearings. If necessary, grind or replace the crankshaft.

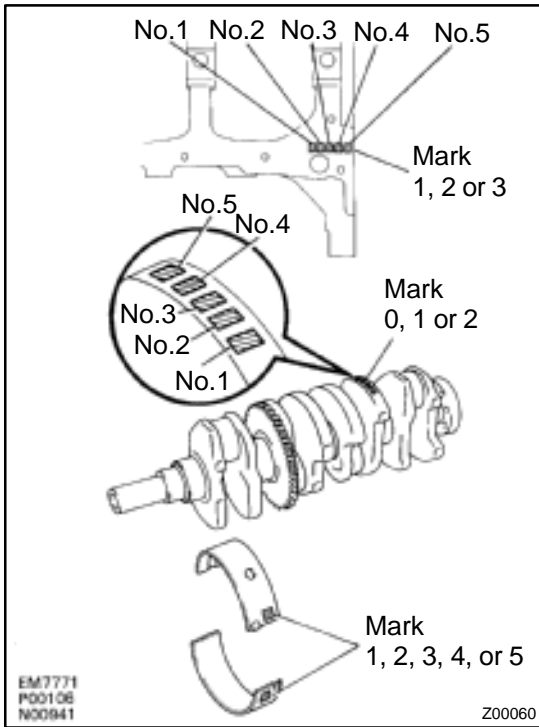

HINT:

If using a standard bearing, replace it with one having the same number. If the number of the bearing cannot be determined, select the correct bearing by adding together the numbers imprinted on the cylinder block and crankshaft, then selecting the bearing with the same number as the total. There are 5 sizes of standard bearings, marked "1", "2", "3", "4" and "5" accordingly.

	Number marked								
	1			2			3		
Cylinder block									
Crankshaft	0	1	2	0	1	2	0	1	2
Use bearing	1	2	3	2	3	4	3	4	5

EXAMPLE: Cylinder block "2" + Crankshaft "1"
= Total number 3 (Use bearing "3")

Reference

Cylinder block main journal bore diameter:

Mark "1"	59.020 – 59.026 mm (2.3236 – 2.3239 in.)
Mark "2"	59.026 – 59.032 mm (2.3239 – 2.3241 in.)
Mark "3"	59.032 – 59.038 mm (2.3241 – 2.3243 in.)

Crankshaft main journal diameter:

Mark "0"	54.998 – 55.003 mm (2.1653 – 2.1655 in.)
Mark "1"	54.993 – 54.998 mm (2.1651 – 2.1653 in.)
Mark "2"	54.988 – 54.993 mm (2.1649 – 2.1651 in.)

Standard sized bearing center wall thickness:

No.3

Mark "1"	1.992 – 1.995 mm (0.0784 – 0.0785 in.)
Mark "2"	1.995 – 1.998 mm (0.0785 – 0.0787 in.)
Mark "3"	1.998 – 2.001 mm (0.0787 – 0.0788 in.)
Mark "4"	2.001 – 2.004 mm (0.0788 – 0.0789 in.)
Mark "5"	2.004 – 2.007 mm (0.0789 – 0.0790 in.)

Others

Mark "1"	1.997 – 2.000 mm (0.0786 – 0.0787 in.)
Mark "2"	2.000 – 2.003 mm (0.0787 – 0.0789 in.)
Mark "3"	2.003 – 2.006 mm (0.0789 – 0.0790 in.)
Mark "4"	2.006 – 2.009 mm (0.0790 – 0.0791 in.)
Mark "5"	2.009 – 2.012 mm (0.0791 – 0.0792 in.)

(k) Completely remove the Plastigage.

19. REMOVE CRANKSHAFT

- (a) Lift out the crankshaft.
- (b) Remove the 5 upper bearings and 2 upper thrust washers from the cylinder block.

HINT:

Arrange the main bearing caps, bearings and thrust washers in the correct order.

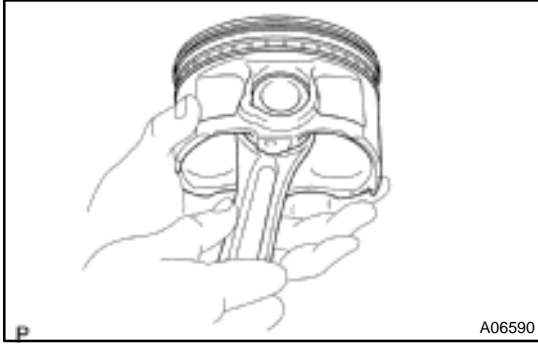
**20. CHECK FIT BETWEEN PISTON AND PISTON PIN**

Try to move the piston back and forth on the piston pin.
If any movement is felt, replace the piston and pin as a set.

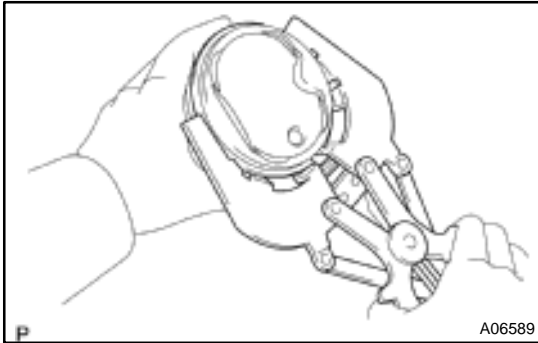
**21. REMOVE PISTON RINGS**

(a) Using a piston ring expander, remove the No.1 and No.2 piston rings.

(b) Remove the 2 side rails and oil ring expander by hand.

HINT:

Arrange the piston rings in correct order only.

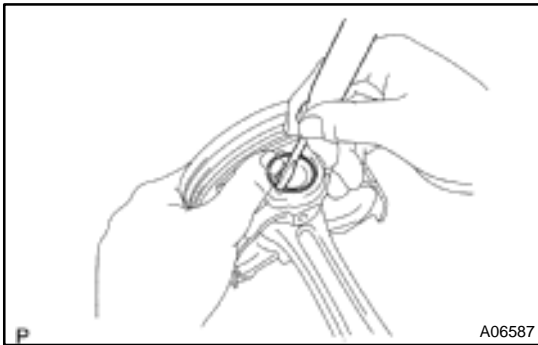
**22. DISCONNECT CONNECTING ROD FROM PISTON**

(a) Using a small screwdriver, pry out the 2 snap rings.

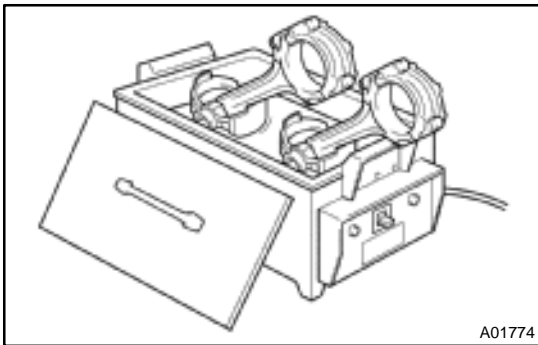

(b) Gradually heat the piston to 80 – 90°C (176 – 194°F).

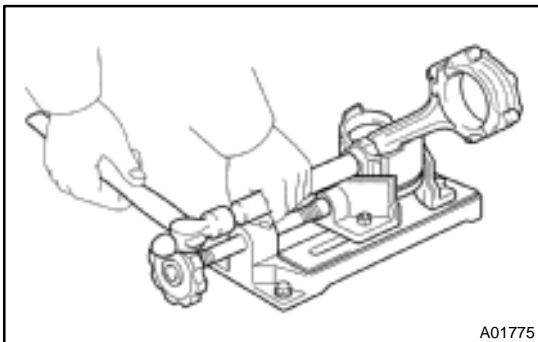

(c) Using a plastic-faced hammer and brass bar, lightly tap out the piston pin and remove the connecting rod.

HINT:

The piston and pin are a matched set.

Arrange the pistons, pins, connecting rods and bearings in the correct order.

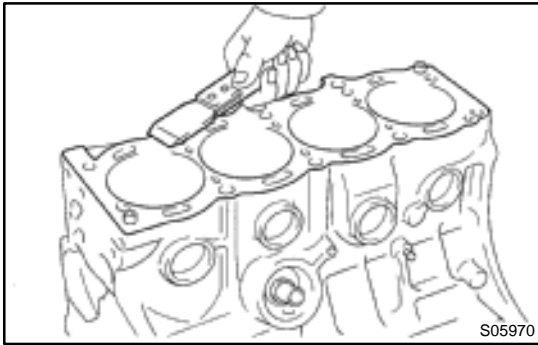

INSPECTION

1. CLEAN CYLINDER BLOCK

- (a) Remove the gasket material.
Using a gasket scraper, remove all the gasket material from the top surface of the cylinder block.
- (b) Clean the cylinder block.
Using a soft brush and solvent, thoroughly clean the cylinder block.

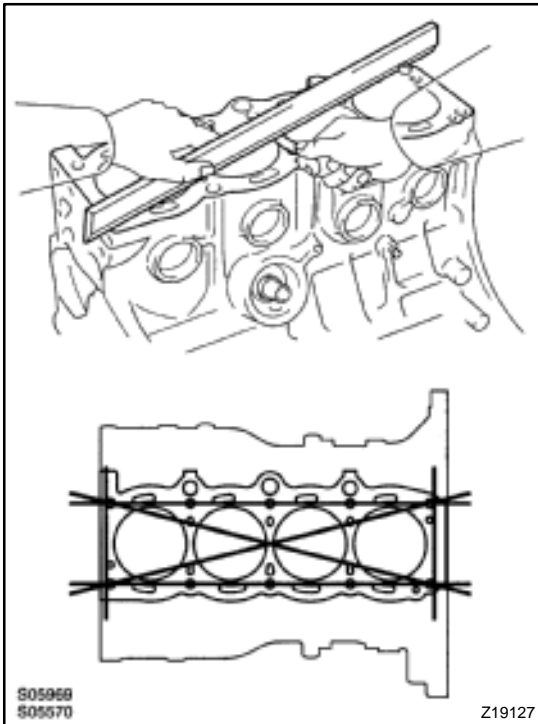

2. INSPECT CYLINDER BLOCK

- (a) Inspect for flatness.
Using a precision straight edge and feeler gauge, measure the surfaces contacting the cylinder head gasket for warpage.

Maximum warpage: 0.05 mm (0.0020 in.)

If warpage is greater than maximum, replace the cylinder block.

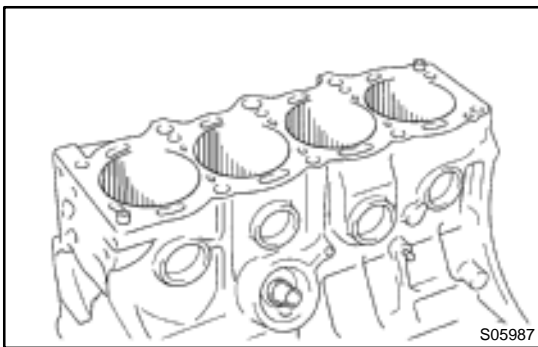

- (b) Visually check the cylinder for vertical scratches.
If deep scratches are present, rebore all the 4 cylinders and replace all the 4 pistons. (See page EM-104) If necessary, replace the cylinder block.

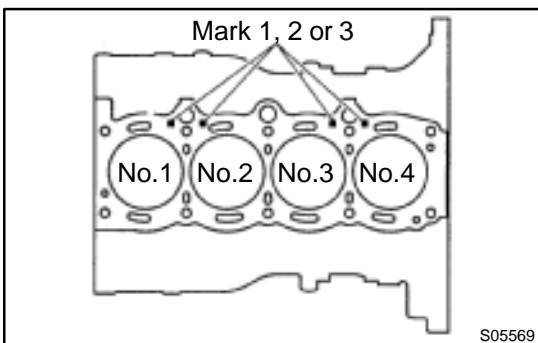

- (c) Inspect the cylinder bore diameter.

HINT:

There are 3 sizes of the standard cylinder bore diameter, marked "1", "2" and "3" accordingly. The mark is stamped on the top of the cylinder block.

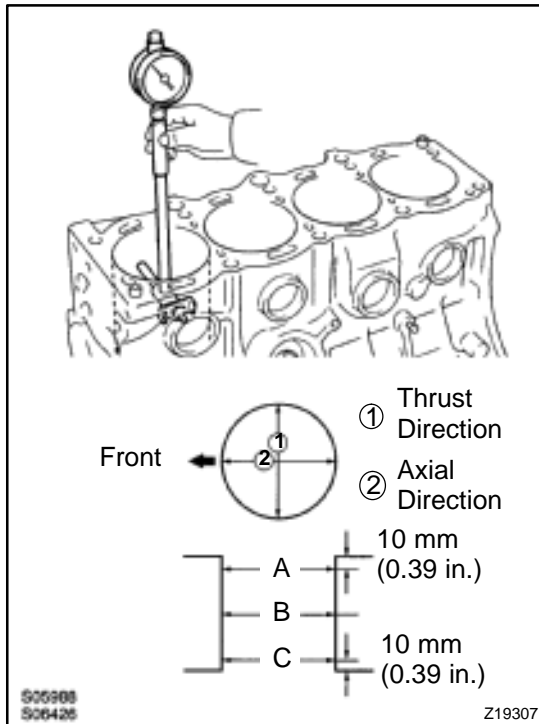

Using a cylinder gauge, measure the cylinder bore diameter at positions A, B and C in the thrust and axial directions.

Standard diameter:

Mark "1"	87.000 – 87.010 mm (3.4252 – 3.4256 in.)
Mark "2"	87.010 – 87.020 mm (3.4256 – 3.4262 in.)
Mark "3"	87.020 – 87.030 mm (3.4260 – 3.4264 in.)

Maximum diameter:

STD	87.23 mm (3.4342 in.)
O/S 0.50	87.73 mm (3.4350 in.)

If the diameter is greater than maximum, rebore all the 4 cylinders and replace all the 4 pistons. (See page EM-104) If necessary, replace the cylinder block.

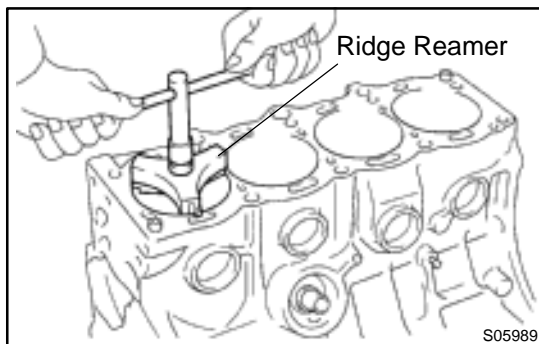

(d) Remove the cylinder ridge.

If the wear is less than 0.2 mm (0.008 in.), using a ridge reamer, grind the top of the cylinder.

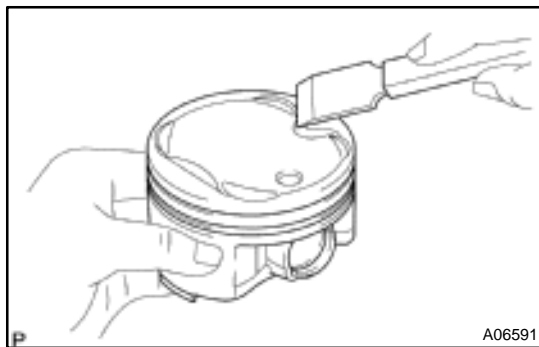

3. CLEAN PISTON

(a) Using a gasket scraper, remove the carbon from the piston top.

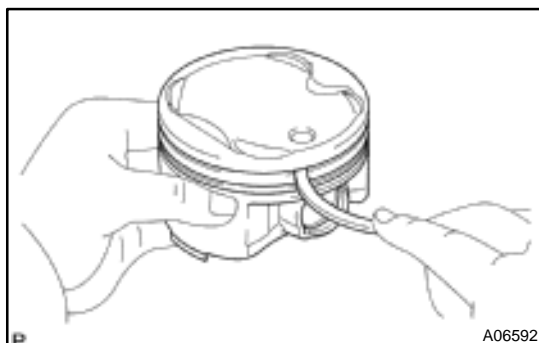

(b) Using a groove cleaning tool or broken ring, clean the piston ring grooves.

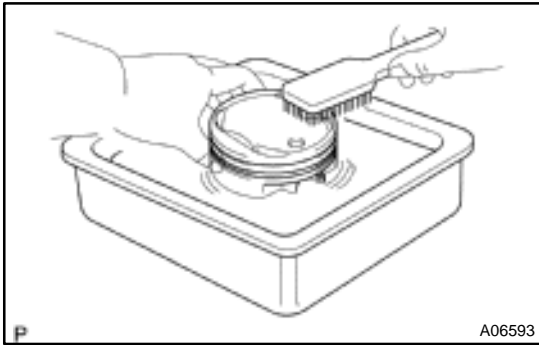

(c) Using solvent and a brush, thoroughly clean the piston.

NOTICE:

Do not use a wire brush.

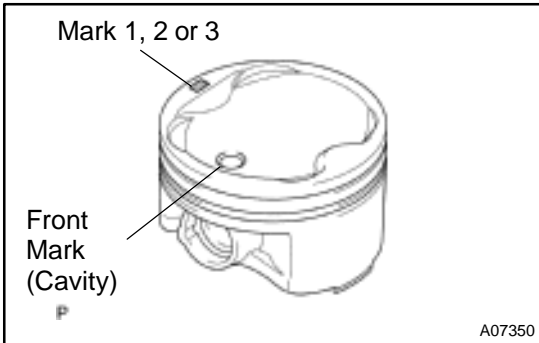

4. INSPECT PISTON AND CONNECTING ROD

(a) Inspect the piston oil clearance.

HINT:

There are 3 sizes of the standard piston diameter, marked "1", "2" and "3" accordingly. The mark is stamped on the piston top.

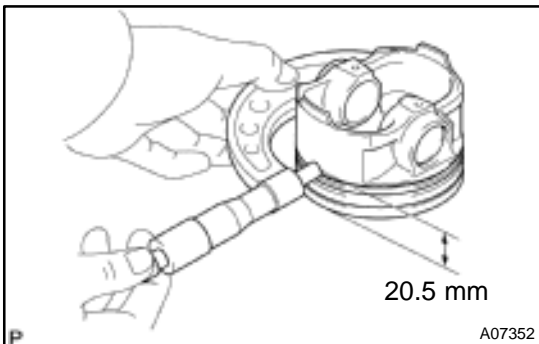

(1) Using a micrometer, measure the piston diameter at right angles to the piston pin center line, 20.5 mm (0.807 in.) from the piston head.

Piston diameter:

STD	Mark "1"	86.815 – 86.825 mm (3.4179 – 3.4183 in.)
	Mark "2"	86.825 – 86.835 mm (3.4183 – 3.4186 in.)
	Mark "3"	86.835 – 86.845 mm (3.4186 – 3.4190 in.)
O/S 0.50		87.315 – 87.345 mm (3.4375 – 3.4387 in.)

- (2) Measure the cylinder bore diameter in the thrust directions. (See step 2)
- (3) Subtract the piston diameter measurement from the cylinder bore diameter measurement.

Standard oil clearance:

0.175 – 0.195 mm (0.0068 – 0.0076 in.)

Maximum oil clearance: 0.215 mm (0.0085 in.)

If the oil clearance is greater than maximum, replace all the 4 pistons and rebore all the 4 cylinders. (See page EM-104) If necessary, replace the cylinder block.

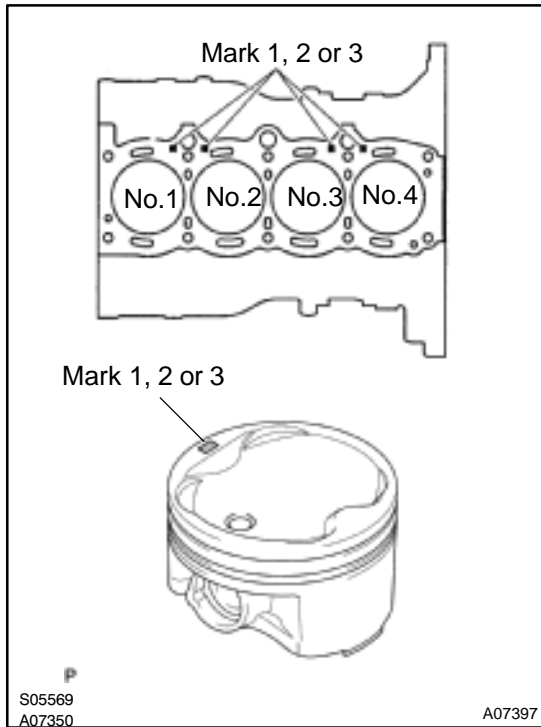

HINT:

Use new cylinder block:

Use a piston with the same number mark as the cylinder bore diameter marked on the cylinder block.

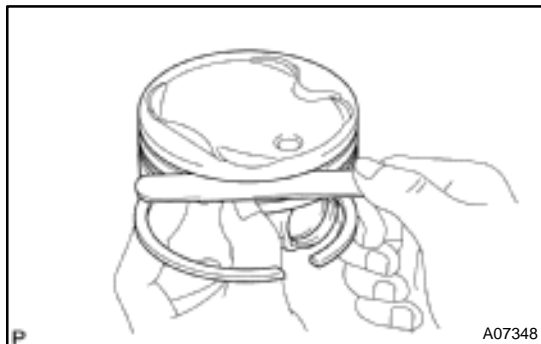

- (b) Inspect the piston ring groove clearance. Using a feeler gauge, measure the clearance between new piston ring and the wall of the ring groove.

Ring groove clearance (No.1, No.2):
0.030 – 0.070 mm (0.0012 – 0.0028 in.)

If the clearance is not as specified, replace the piston.

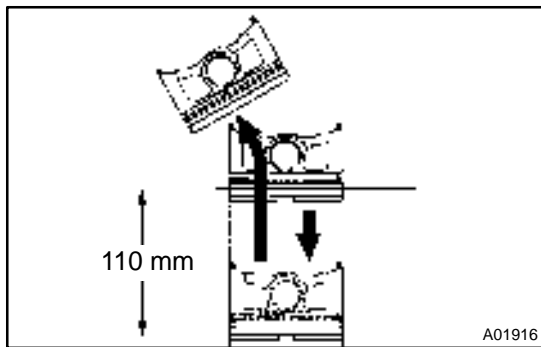

- (c) Inspect the piston ring end gap.
 - (1) Insert the piston ring into the cylinder bore.
 - (2) Using a piston, push the piston ring a little beyond the bottom of the ring travel, 110 mm (4.33 in.) from the top of the cylinder block.

- (3) Using a feeler gauge, measure the end gap.

Standard end gap:

No.1	0.270 – 0.490 mm (0.0106 – 0.0192 in.)
No.2	0.450 – 0.670 mm (0.0177 – 0.0263 in.)
Oil (Side rail)	0.100 – 0.470 mm (0.0039 – 0.0185 in.)

Maximum end gap:

No.1	1.09 mm (0.0429 in.)
No.2	1.27 mm (0.0499 in.)
Oil (Side rail)	1.07 mm (0.0421 in.)

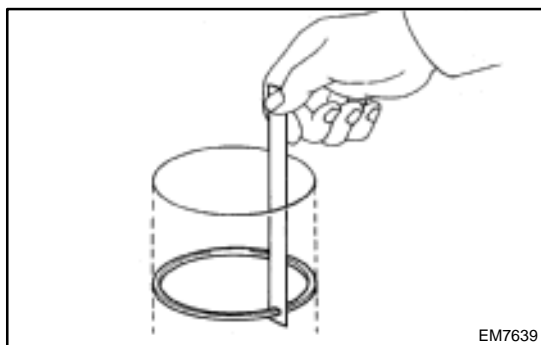

If the end gap is greater than maximum, replace the piston ring. If the end gap is greater than maximum, even with a new piston ring, rebore all the 4 cylinders (see page EM-104) or replace the cylinder block.

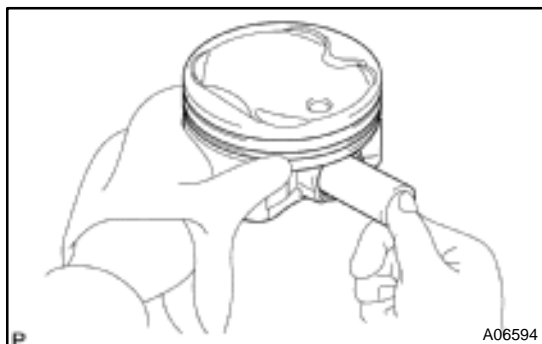

- (d) Inspect the piston pin fit.
At 60°C (140°F), you should be able to push the piston pin into the piston pin hole with your thumb.

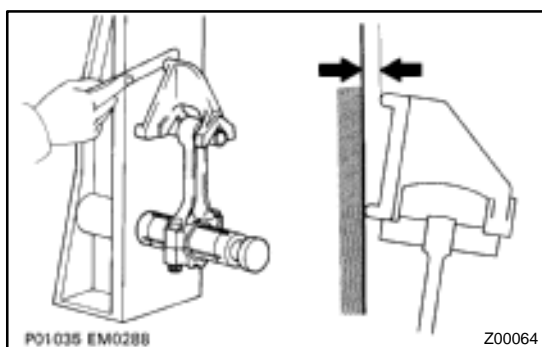

- (e) Using a rod aligner and feeler gauge, check the connecting rod alignment.

(1) Check for bend.

Maximum bend:

0.05 mm (0.0020 in.) per 100 mm (3.94 in.)

If bend is greater than maximum, replace the connecting rod assembly.

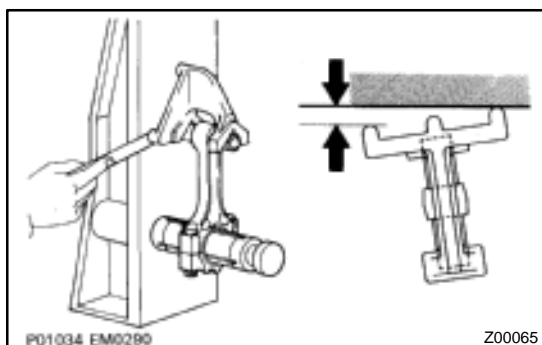

(2) Check for twist

Maximum twist:

0.15 mm (0.0059 in.) per 100 mm (3.94 in.)

If twist is greater than maximum, replace the connecting rod assembly.

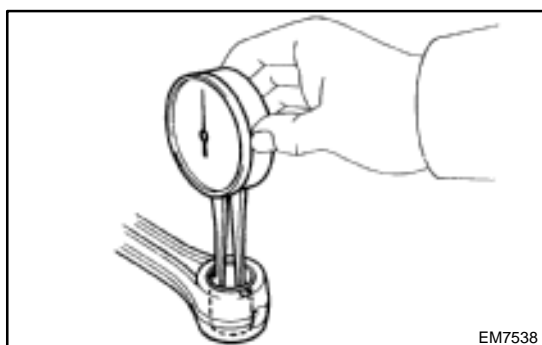

- (f) Inspect the piston pin oil clearance.
(1) Using a caliper gauge, measure the inside diameter of the connecting rod bushing.

Bushing inside diameter:

22.005 – 22.017 mm (0.8663 – 0.8668 in.)

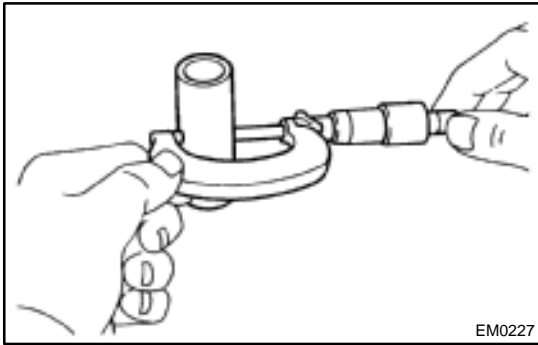

- (2) Using a micrometer, measure the piston pin diameter.

Piston pin diameter:

21.997 – 22.009 mm (0.8660 – 0.8665 in.)

- (3) Subtract the piston pin diameter measurement from the bushing inside diameter measurement.

Standard oil clearance:

0.005 – 0.011 mm (0.0002 – 0.0004 in.)

Maximum oil clearance: 0.05 mm (0.0020 in.)

If the oil clearance is greater than maximum, replace the bushing. (See page EM-104) If necessary, replace the piston and piston pin as a set.

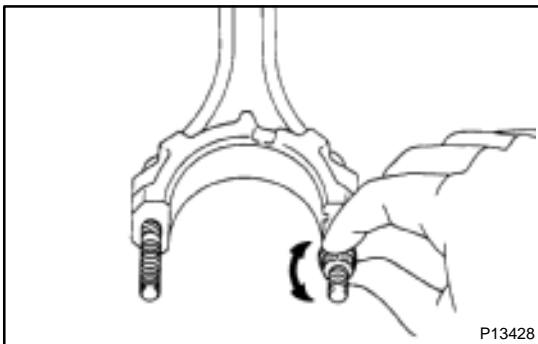

- (g) Inspect the connecting rod bolts.

- (1) Install the cap nut to the connecting rod bolt. Check that the cap nut can be turned easily by hand to the end of the thread.

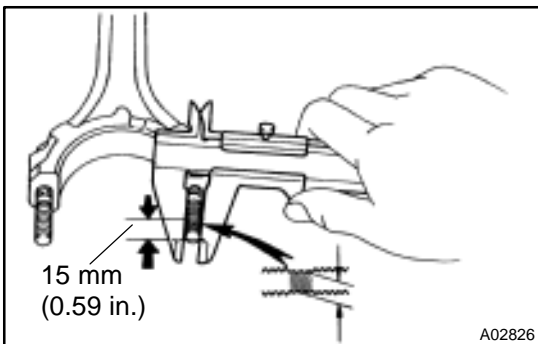

- (2) If the cap nut cannot be turned easily, measure the outside diameter of the connecting rod bolt with a vernier caliper.

Standard diameter:

7.860 – 8.000 mm (0.3094 – 0.3150 in.)

Minimum diameter: 7.60 mm (0.2992 in.)

HINT:

If the location of this area cannot be judged by visual inspection, measure the outer diameter at the location shown in the illustration.

If the outside diameter is less than minimum, replace the connecting rod bolt and nut as a set.

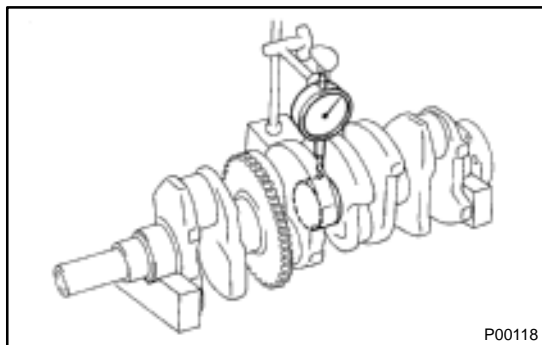

5. INSPECT CRANKSHAFT

- (a) Inspect for circle runout.
- (1) Place the crankshaft on V-blocks.
 - (2) Using a dial indicator, measure the circle runout at the center journal.

Maximum circle runout: 0.06 mm (0.0024 in.)

If the circle runout is greater than maximum, replace the crankshaft.

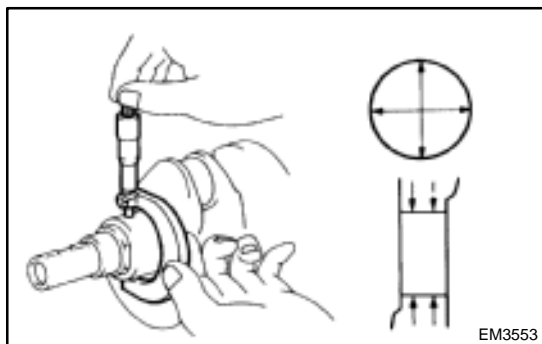

- (b) Inspect the main journals and crank pins.
- (1) Using a micrometer, measure the diameter of each main journal and crank pin.

Main journal diameter:

STD	54.988 – 55.003 mm (2.1653 – 2.1655 in.)
U/S 0.25	54.745 – 54.755 mm (2.1553 – 2.1557 in.)

Crank pin diameter:

STD	51.985 – 52.000 mm (2.0466 – 2.0472 in.)
U/S 0.25	51.745 – 51.755 mm (2.0372 – 2.0376 in.)

If the diameter is not as specified, check the oil clearance. (See page EM-86) If necessary, grind or replace the crankshaft.

- (2) Check each main journal and crank pin for taper and out-of-round as shown.

**Maximum taper and out-of-round:
0.02 mm (0.0008 in.)**

If the taper and out-of-round is greater than maximum, replace the crankshaft.

6. IF NECESSARY, GRIND AND HONE MAIN JOURNALS AND/OR CRANK PINS

Grind and hone the main journals and/or crank pins to the finished undersized diameter. (See procedure in step 5) Install new main journal and/or crankshaft pin undersized bearings.

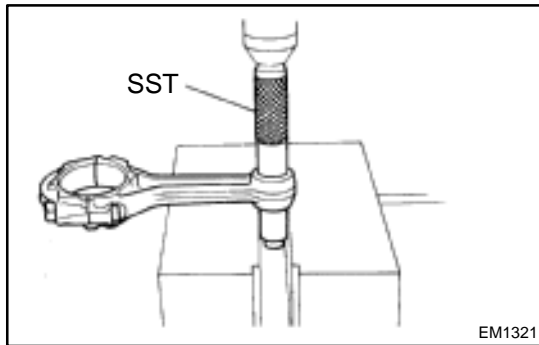

REPLACEMENT

1. REPLACE CONNECTING ROD BUSHINGS

- (a) Using SST and a press, press out the bushing.
SST 09222-30010

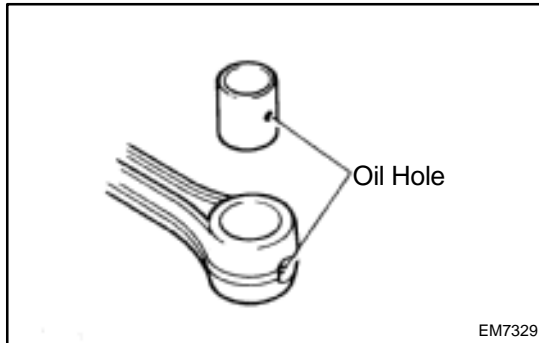

- (b) Align the oil holes of a new bushing and the connecting rod.

- (c) Using SST and a press, press in the bushing.
SST 09222-30010

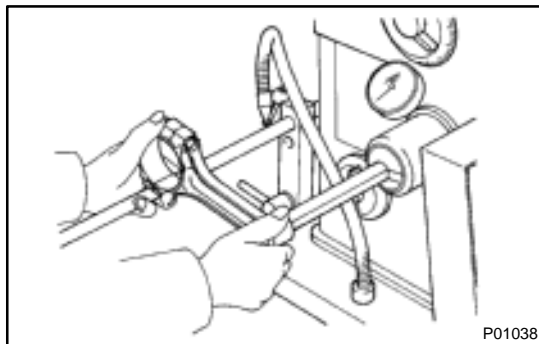

- (d) Using a pin hole grinder, hone the bushing to obtain the standard specified clearance (See page EM-97) between the bushing and piston pin.

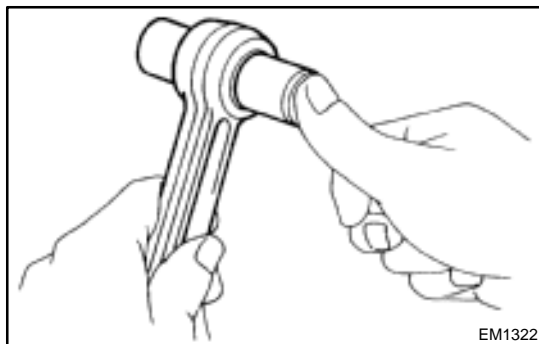

- (e) Check the piston pin fit at normal room temperature. Coat the piston pin with engine oil, and push it into the connecting rod with your thumb.

2. REPLACE OVERSIZED (O/S) PISTONS FOR CYLINDER BORING

HINT:

Bore all the 4 cylinders for the O/S piston outside diameter.

Replace all the piston rings with ones to match the O/S pistons.

- (a) Keep 4 new O/S pistons.

O/S 0.50 piston diameter:

87.350 – 87.380 mm (3.4390 – 3.4402 in.)

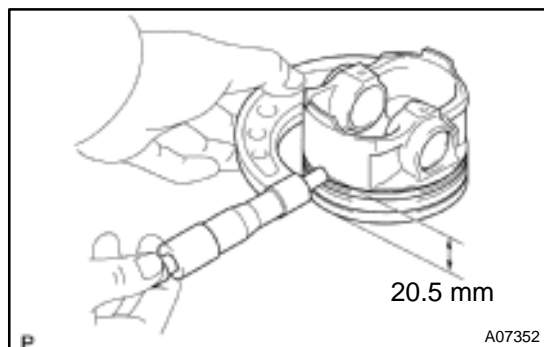

(b) Using a micrometer, measure the piston diameter at right angles to the piston pin center line, 20.5 mm (0.807 in.) from the piston head.

(c) Calculate the amount of each cylinder is to be rebored as follows:

$$\text{Size to be rebored} = P + C - H$$

P = Piston diameter

C = Piston oil clearance

0.175 – 0.195 mm (0.0068 – 0.0076 in.)

H = Allowance for honing

0.02 mm (0.0008 in.) or less

(d) Bore and hone the cylinders to calculated dimensions.

Maximum honing: 0.02 mm (0.0008 in.)

NOTICE:

Excess honing will destroy the finished roundness.

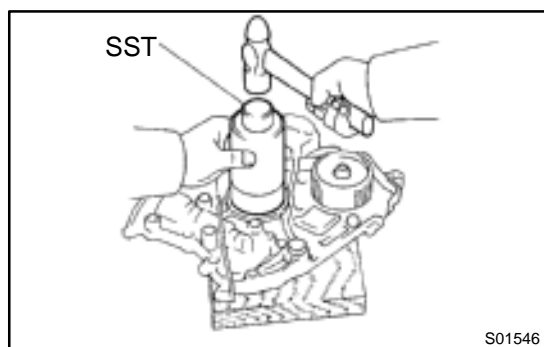

3. REPLACE CRANKSHAFT FRONT OIL SEAL

HINT:

There are 2 methods ((a) and (b)) to replace the oil seal.

(a) If the oil pump is removed from the cylinder block:

(1) Using a screwdriver and hammer, tap out the oil seal.

(2) Using SST and a hammer, tap in a new oil seal until its surface is flush with the oil pump body edge.

SST 09226-10010

(3) Apply MP grease to the oil seal lip.

(b) If the oil pump is installed to the cylinder block:

(1) Using a knife, cut off the oil seal lip.

(2) Using a screwdriver, pry out the oil seal.

NOTICE:

Be careful not to damage the crankshaft. Tape the screwdriver tip.

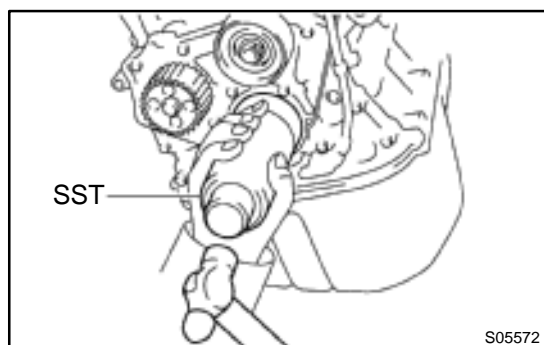
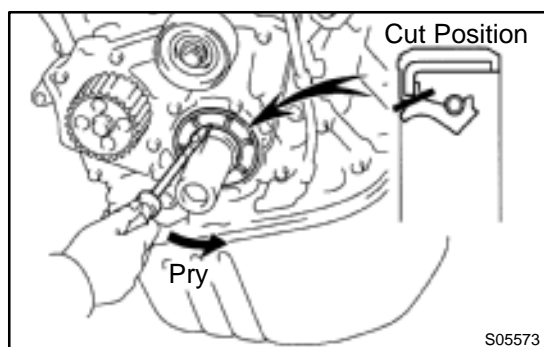

(3) Apply MP grease to a new oil seal lip.

(4) Using SST and a hammer, tap in the oil seal until its surface is flush with the oil pump body edge.

SST 09226-10010

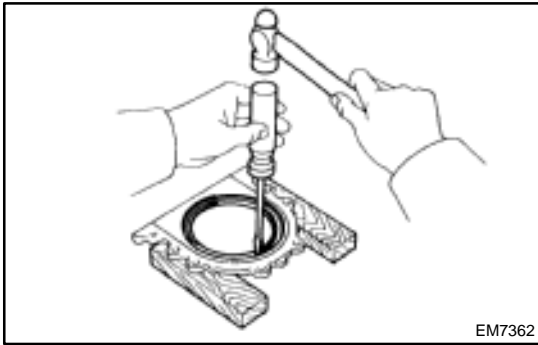

4. REPLACE CRANKSHAFT REAR OIL SEAL

HINT:

there are 2 methods ((a) and (b)) to replace the oil seal.

(a) If the rear oil seal retainer is removed from the cylinder block:

(1) Using a screwdriver and hammer, tap out the oil seal.

(2) Using SST and a hammer, tap in a new oil seal until its surface is flush with the rear oil seal retainer edge.

SST 09223-15030, 09950-70010 (09951-07100)

(3) Apply MP grease to the oil seal lip.

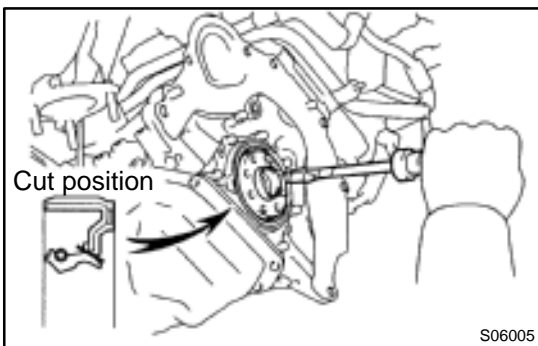
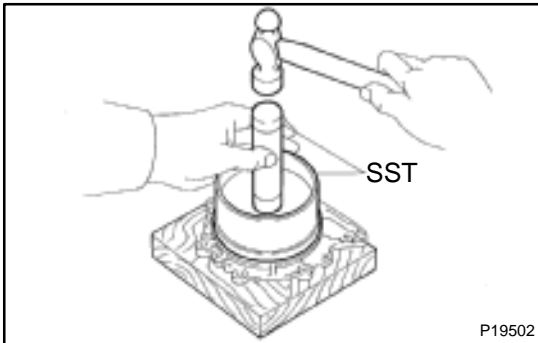

(b) If rear oil seal retainer is installed to cylinder block:

(1) Using a knife, cut off the oil seal lip.

(2) Using a screwdriver, pry out the oil seal.

NOTICE:

Be careful not to damage the crankshaft. Tape the screwdriver tip.

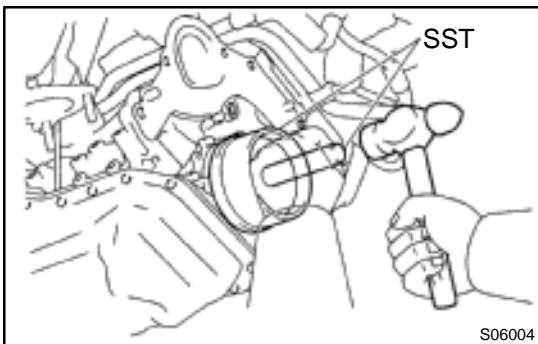

(3) Apply MP grease to a new oil seal lip.

(4) Using SST and a hammer, tap in the oil seal until its surface is flush with the rear oil seal retainer edge.

SST 09223-15030, 09950-70010 (09951-07100)

REASSEMBLY

HINT:

Thoroughly clean all parts to be assembled.

Before installing the parts, apply new engine oil to all sliding and rotating surfaces.

Replace all gaskets, O-rings and oil seals with new parts.

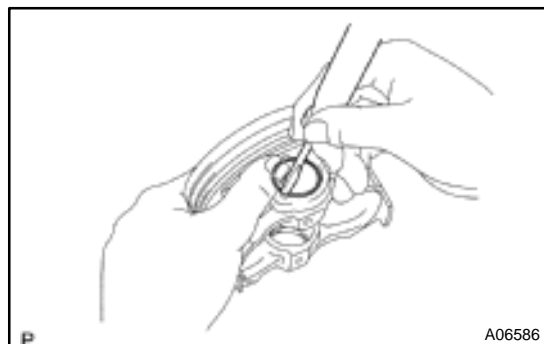

1. ASSEMBLE PISTON AND CONNECTING ROD

- (a) Using a small screwdriver, install a new snap ring on one side of the piston pin hole.

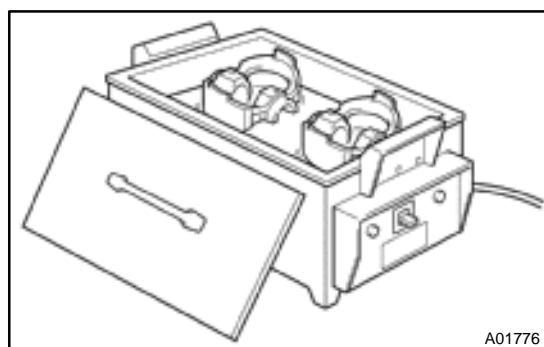

- (b) Gradually heat the piston to 80 – 90°C (176 – 194°F).

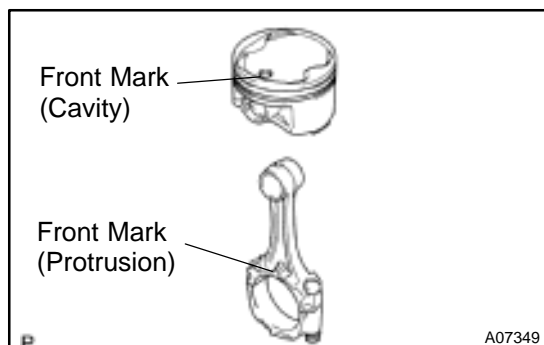

- (c) Coat the piston pin with engine oil.
 (d) Align the front marks of the piston and connecting rod, and push in the piston pin with your thumb.

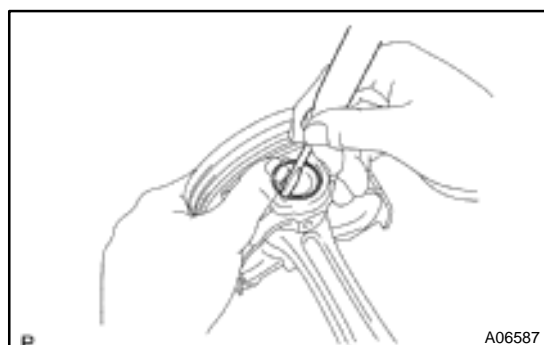

- (e) Using a small screwdriver, install a new snap ring on the other side of the piston pin hole.

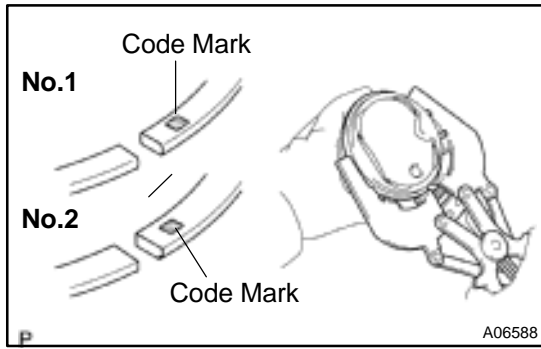

2. INSTALL PISTON RINGS

- (a) Install the oil ring expander and 2 side rails by hand.
- (b) Using a piston ring expander, install the No.2 and No.1 piston rings with the code mark facing upward.

Code mark:

No.1	1N or T
No.2	2N or 2T

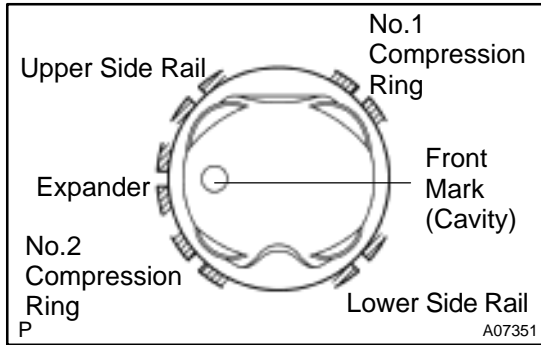

- (c) Position the piston rings so that the ring ends are as shown.

NOTICE:

Do not align the ring ends.



3. INSTALL BEARINGS

- (a) Align the bearing claw with the groove of the connecting rod or connecting cap.
- (b) Install the bearings in the connecting rod and connecting rod cap.

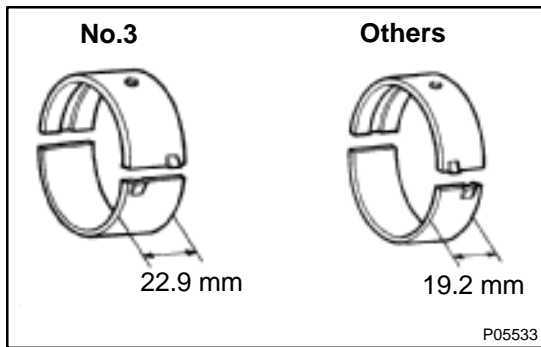

4. INSTALL MAIN BEARINGS

HINT:

Main bearings come in widths of 19.2 mm (0.756 in.) and 22.9 mm (0.902 in.). Install the 22.9 mm (0.902 in.) bearings in the No.3 cylinder block journal position with the main bearing cap. Install the 19.2 mm (0.756 in.) bearings in the other positions.

Upper bearings have an oil groove and oil holes; lower bearings do not.

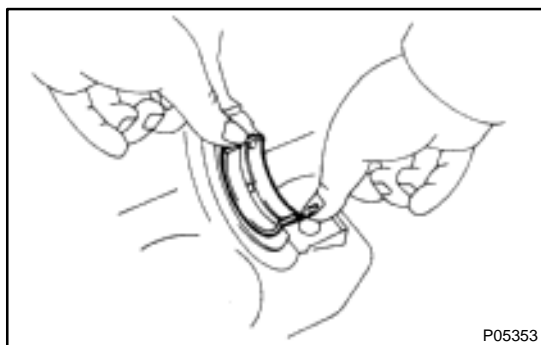

- (a) Align the bearing claw with the claw groove of the cylinder block, and push in the 5 upper bearings.

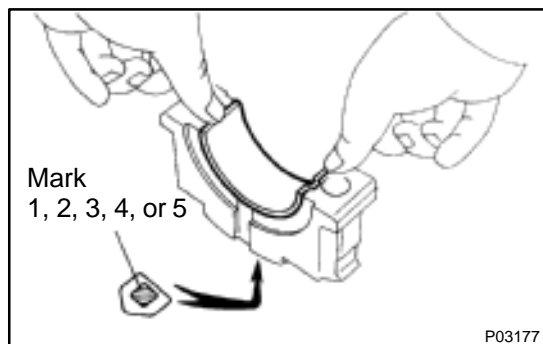

- (b) Align the bearing claw with the claw groove of the main bearing cap, and push in the 5 lower bearings.

HINT:

A number is marked on each main bearing cap to indicate the installation position.

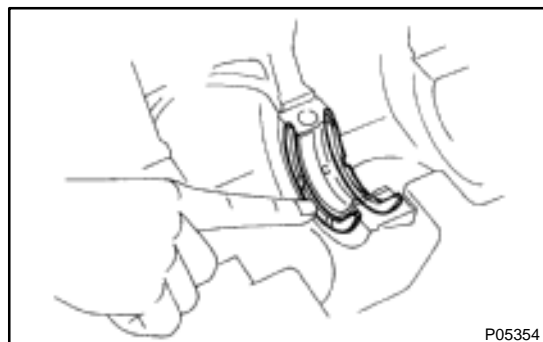

5. INSTALL UPPER THRUST WASHERS

Install the 2 thrust washers under the No.3 journal position of the cylinder block with the oil grooves facing outward.

6. PLACE CRANKSHAFT ON CYLINDER BLOCK

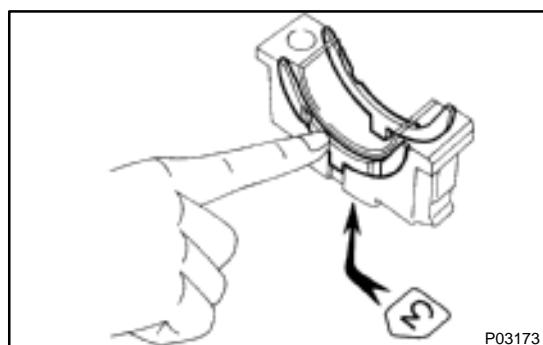

7. INSTALL MAIN BEARING CAPS AND LOWER THRUST WASHERS

- (a) Install the 2 thrust washers on the No.3 bearing cap with the grooves facing outward.

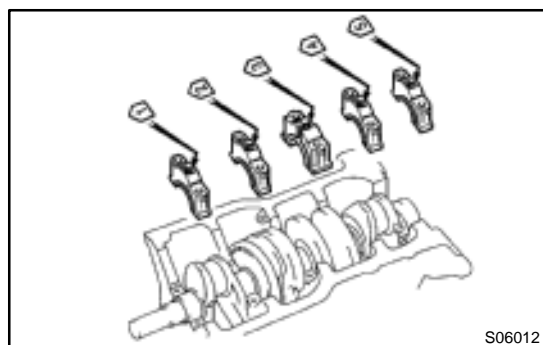

- (b) Install the 5 main bearing caps in their proper locations.

HINT:

Each bearing cap has a number and front mark.

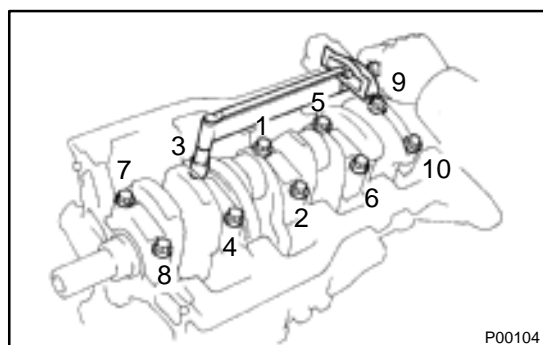

- (c) Apply a light coat of engine oil on the threads and under the heads of the main bearing cap bolts.
- (d) Install and uniformly tighten the 10 bolts of the main bearing cap in several passes, in the sequence shown.

Torque: 59 N·m (600 kgf·cm, 43 ft·lbf)

- (e) Check that the crankshaft turns smoothly.

8. CHECK CRANKSHAFT THRUST CLEARANCE (See page EM-86)

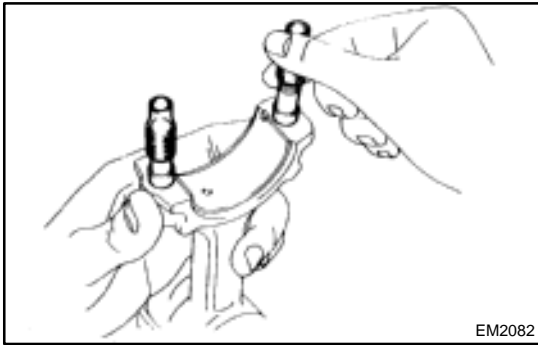

9. INSTALL PISTON AND CONNECTING ROD ASSEMBLES

- (a) Cover the connecting rod bolts with a short piece of hose to protect the crankshaft from damage.

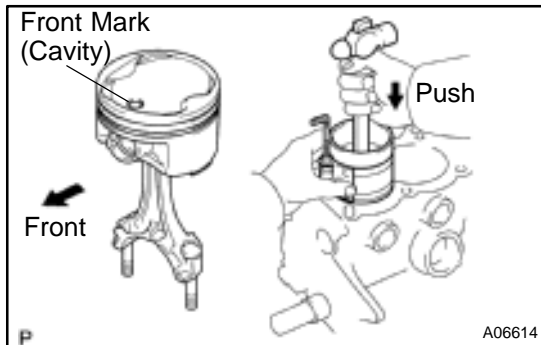

- (b) Using a piston ring compressor, push the correctly numbered piston and connecting rod assemblies into each cylinder with the front mark of the piston facing forward.

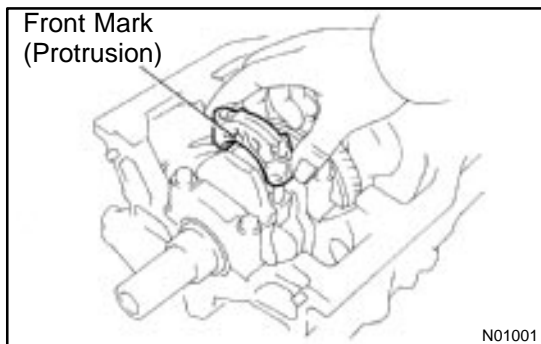

10. PLACE CONNECTING ROD CAP ON CONNECTING ROD

- (a) Match the numbered connecting rod cap with the connecting rod.
- (b) Install the connecting rod cap with the front mark facing forward.

11. INSTALL CONNECTING ROD CAP NUTS

HINT:

The cap nuts are tightened in 2 progressive steps (steps (b) and (d)).

If any one of the connecting rod bolts is broken or deformed, replace it.

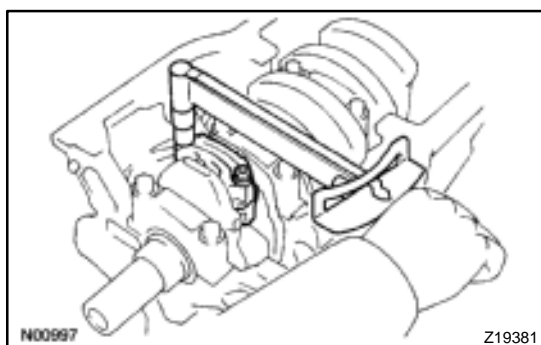

- (a) Apply a light coat of engine oil on the threads and under the nuts of the connecting rod cap.
- (b) Install and alternately tighten the 2 cap nuts in several passes.

Torque: 25 N·m (250 kgf·cm, 18 ft·lbf)

If any one of the cap nuts does not meet the torque specification, replace the connecting rod bolt and cap nut as a set.

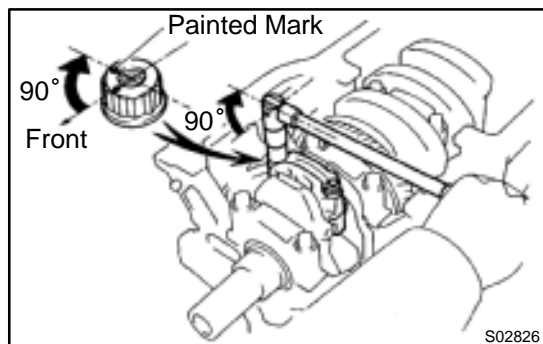

- (c) Mark the front of the cap nut with the paint.
- (d) Retighten the cap nuts 90° as shown.
- (e) Check that the painted mark is now at a 90° angle to the front.
- (f) Check that the crankshaft turns smoothly.

**12. CHECK CONNECTING ROD THRUST CLEARANCE
(See page EM-86)**

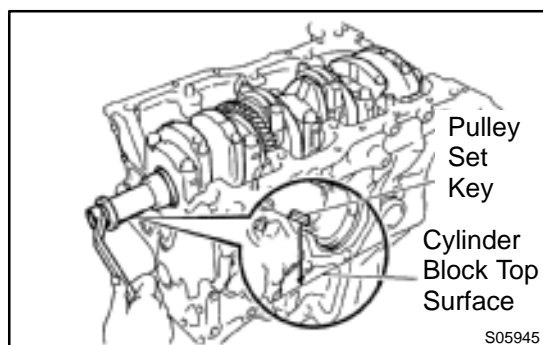

13. INSTALL ENGINE BALANCER

- (a) Turn the crankshaft, and set the No.1 cylinder TDC as shown in the illustration.

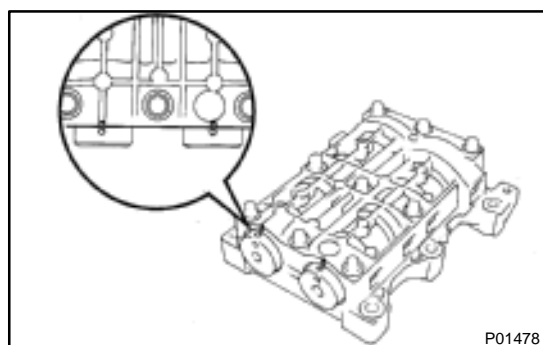

- (b) Set the balance shafts so that the punch marks of the balance shafts are aligned with the grooves of the No.2 housing.

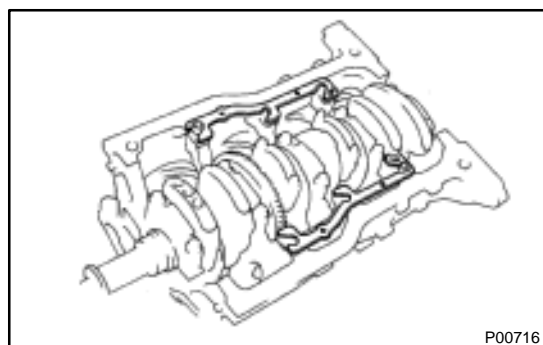

- (c) Wipe clean the installation surface of the spacer.
- (d) Place the spacers on the cylinder block.

HINT:

When replacing the crankshaft and/or balance shaft, use the thickest spacers.

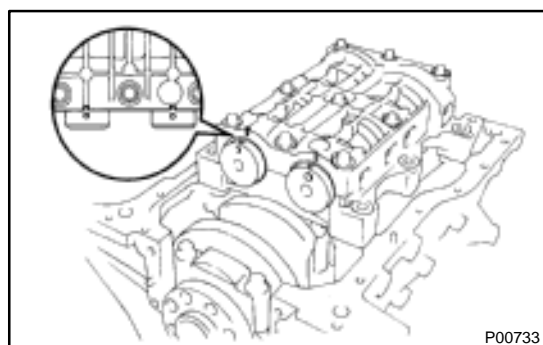

- (e) Place the engine balancer on the cylinder block.
- (f) Check that punch marks shown in the illustration of the balance shafts are aligned with the grooves of the No.2 housing.

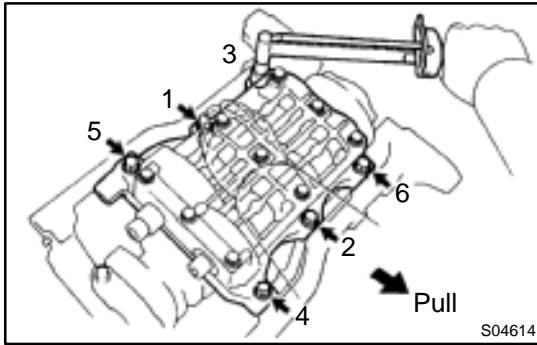

- (g) While pulling the center part of the engine balancer in the direction of the arrow, uniformly tighten the 6 bolts in several passes, in the sequence shown.

Torque: 49 N·m (500 kgf·cm, 36 ft·lbf)

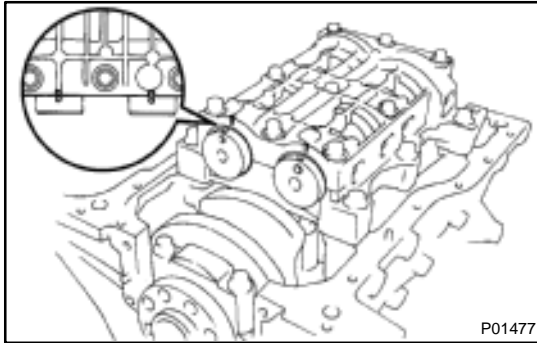

- (h) Recheck that the punch marks of the balance shafts are aligned with the grooves of the No.2 housing.

14. CHECK AND ADJUST BACKLASH OF CRANKSHAFT GEAR AND NO.1 BALANCE SHAFT GEAR

(See page EM-86)

15. INSTALL REAR OIL SEAL RETAINER

Install a new gasket and the retainer with the 6 bolts.

Torque: 13 N·m (130 kgf·cm, 9 ft·lbf)

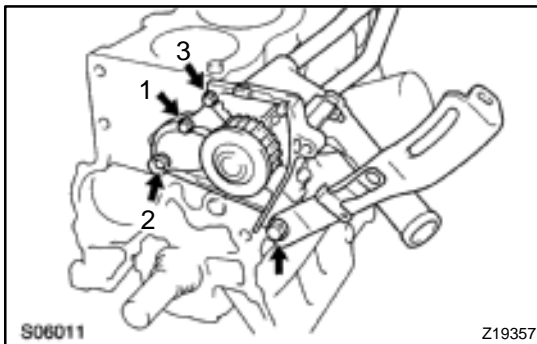

16. INSTALL WATER PUMP, WATER BYPASS PIPE AND OIL COOLER (w/ OIL COOLER) ASSEMBLY

- (a) Install a new O-ring to the water pump cover.
 (b) Install the water pump, water bypass pipe and oil cooler (w/ oil cooler) assembly with the 3 bolts. Tighten the bolts in the sequence shown.

Torque: 8.8 N·m (90 kgf·cm, 78 in.-lbf)

- (c) Install the generator drive belt adjusting bar with the bolt.
Torque: 22 N·m (224 kgf·cm, 16 ft·lbf)

- (d) w/ Oil Cooler:

Install the oil cooler. (See page LU-18)

17. INSTALL OIL FILTER (See page LU-2)

18. INSTALL KNOCK SENSOR 1 (See page SF-57)

19. INSTALL PS PUMP BRACKET

Install the PS pump bracket with the 3 bolts.

Torque: 43 N·m (440 kgf·cm, 32 ft·lbf)

20. INSTALL OIL PUMP AND OIL PAN

- (a) Install the oil pump and oil pan. (See page LU-13)
 (b) Install the crankshaft position sensor connector to the generator drive belt adjusting bar.

21. INSTALL OIL DIPSTICK

22. INSTALL CYLINDER HEAD ASSEMBLY

- (a) Install the cylinder head assembly. (See page EM-33)
 (b) Install the 2 bolts holding the water bypass pipe to the cylinder head.

Torque: 19 N·m (195 kgf·cm, 14 ft·lbf)

- (c) Install the VSV for EGR to the cylinder head with the bolt.

- (d) Connect the knock sensor 1 connector.

- (e) Connect the crankshaft position sensor connector.

- (f) Install the wire clamp to the generator drive belt adjusting bar.
- (g) Connect the IAC valve water bypass hose to the water bypass pipe.
- (h) Connect the water bypass hose (from the water bypass pipe) to the water outlet.
- (i) Install the camshafts. (See page EM-53)
- (j) Install the cylinder head cover.
 - (1) Install the cylinder head cover. (See page EM-53)
 - (2) Connect the PCV hose to the intake manifold.
- (k) Install the No.3 timing belt cover with the 3 bolts.

Torque: 7.8 N·m (80 kgf·cm, 69 in.-lbf)

**23. INSTALL TIMING BELT AND PULLEYS
(See page EM-23)**

24. DISCONNECT ENGINE FROM ENGINE STAND

EXHAUST SYSTEM COMPONENTS

EM08M-03

Heated Oxygen Sensor (Bank 1 Sensor 2)

HINT:

Before installing oxygen sensor, twist sensor wire counterclockwise 3 and 1/2 turns.

After installing oxygen sensor, check that sensor wire is not twisted. If it is twisted, remove oxygen sensor and reinstall it.

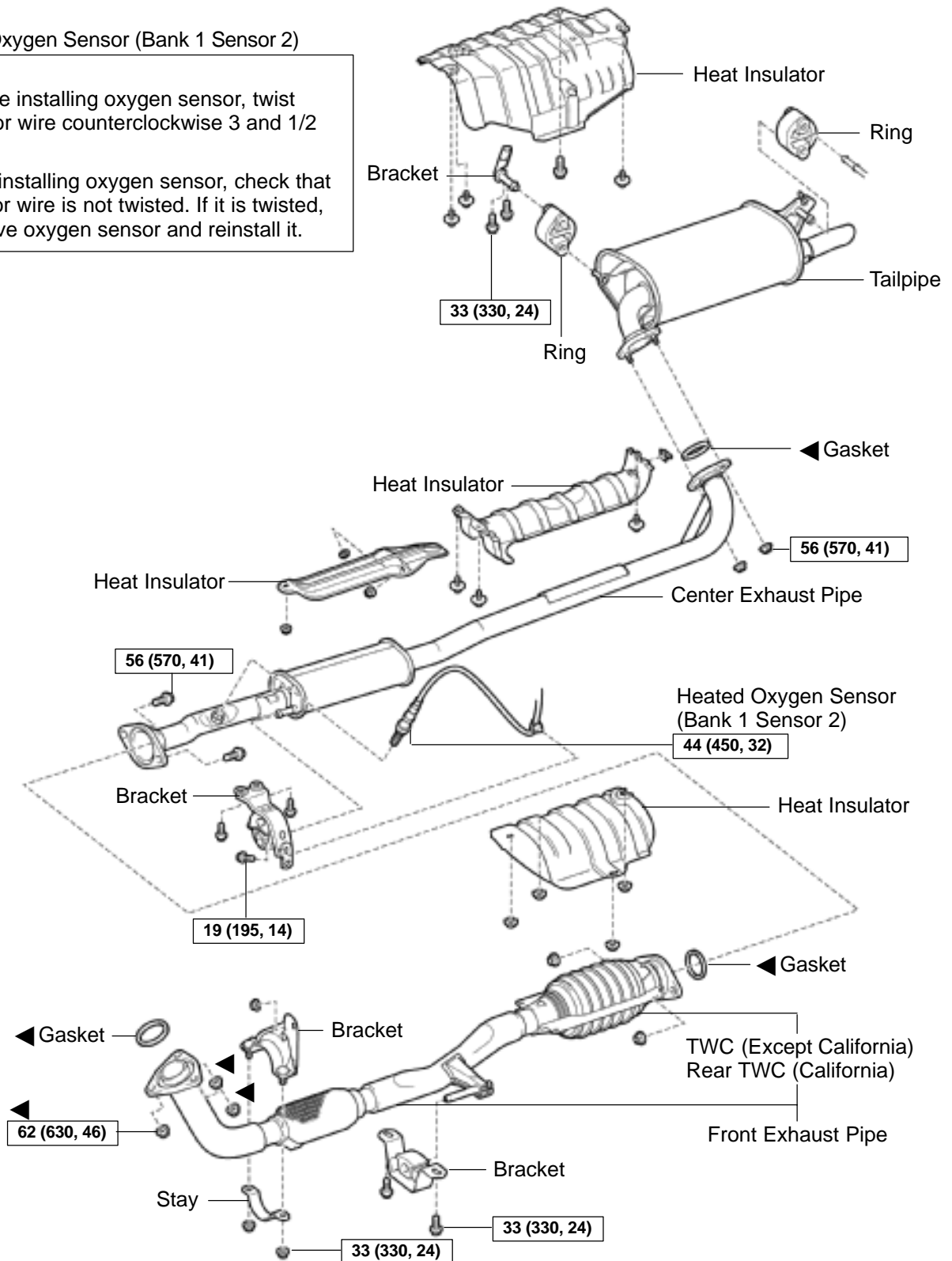

N·m (kgf·cm, ft·lbf) : Specified torque

◀ Non-reusable part

A07369