

SRS AIRBAG

PRECAUTION

RS01Y-22

NOTICE:

- The CAMRY is equipped with SRS, which comprises a driver airbag, front passenger airbag, and side airbag. Failure to carry out service operations in the correct sequence could cause the SRS to unexpectedly deploy during servicing, possibly leading to a serious accident. Further, if a mistake is made in servicing the SRS, it is possible that the SRS may fail to operate when required. Before performing servicing (including removal or installation of parts, inspection or replacement), be sure to read the following items carefully, then follow the correct procedures described in the repair manual.
- Malfunction symptoms of the SRS are difficult to confirm, so the DTCs become the most important source of information when troubleshooting. When troubleshooting the SRS, always inspect the DTCs before disconnecting the battery.
- Even in cases of a minor collision where the SRS does not deploy, the steering wheel pad, front passenger airbag assembly, side airbag assembly (TMC made and TMMK made), airbag sensor assembly, front airbag sensor and side airbag sensor assembly should be inspected.
(See page [RS-16](#), [RS-29](#), [RS-41](#), [RS-54](#), [RS-60](#), [RS-65](#) and [RS-70](#))
- Never use SRS parts from another vehicle. When replacing parts, replace them with new parts.
- Never disassemble and repair the steering wheel pad, front passenger airbag assembly, side airbag assembly, airbag sensor assembly, front airbag sensor or side airbag sensor assembly in order to reuse it.
- If the steering wheel pad, front passenger airbag assembly, side airbag assembly, airbag sensor assembly, front airbag sensor or side airbag sensor assembly has been dropped, or if there are cracks, dents or other defects in the case, bracket or connector, replace them with new ones.
- Use a volt/ohmmeter with high impedance (10 k Ω /V minimum) for troubleshooting the system's electrical circuits.
- Information labels are attached to the periphery of the SRS components. Follow the instructions on the notices.
- After work on the SRS is completed, perform the SRS warning light check (See page [DI-626](#)).
- If the vehicle is equipped with a mobile communication system, refer to the precaution in the IN section.

CAUTION:

- Work must be started 90 seconds after the ignition switch is turned to the "LOCK" position and the negative (-) terminal cable is disconnected from the battery.
(The SRS is equipped with a back-up power source so that if work is started within 90 seconds from disconnecting the negative (-) terminal cable of the battery, the SRS may be deployed.)
- When the negative (-) terminal cable is disconnected from the battery, the memory of the clock and audio system will be canceled. So before starting work, make a record of the contents memorized in the audio memory system. When work is finished, reset the audio systems as they were before and adjust the clock. To avoid erasing the memory in each memory system, never use a back-up power supply from outside the vehicle.
- Before repairs, remove the airbag sensor if shocks are likely to be applied to the sensor during repairs.
- Do not expose the steering wheel pad, front passenger airbag assembly, side airbag assembly, airbag sensor assembly, front airbag sensor or side airbag sensor assembly directly to hot air or flames.

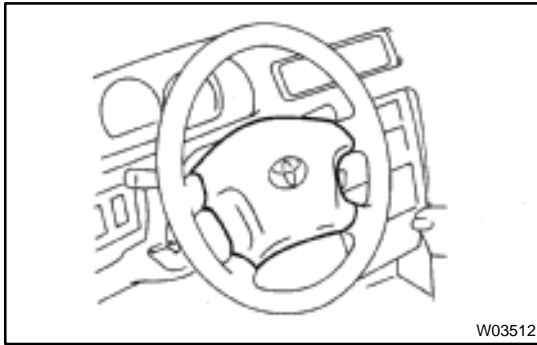

OPERATION

1. STEERING WHEEL PAD (with AIRBAG)

The inflator and bag of the SRS are stored in the steering wheel pad and cannot be disassembled. The inflator contains a squib, igniter charge, gas generant, etc., and inflates the bag when instructed by the airbag sensor assembly.

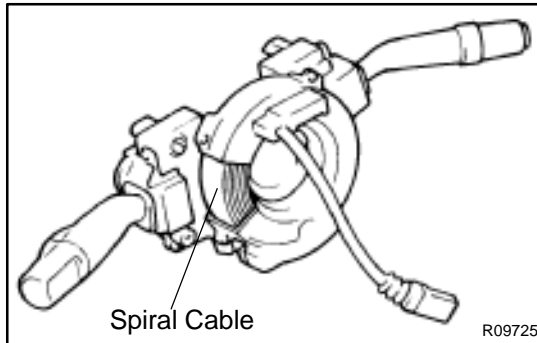

2. SPIRAL CABLE (in COMBINATION SWITCH)

A spiral cable is used as an electrical joint from the vehicle body side to the steering wheel.

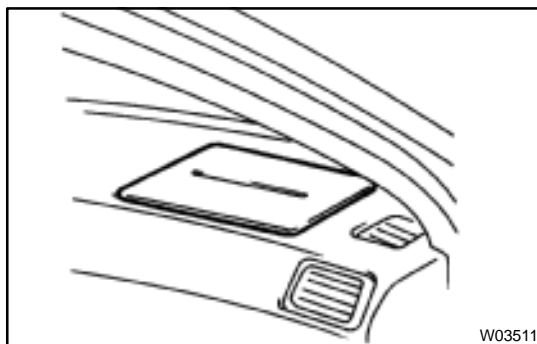

3. FRONT PASSENGER AIRBAG ASSEMBLY

The inflator and bag of the SRS are stored in the front passenger airbag assembly and cannot be disassembled. The inflator contains a squib, igniter charge and gas generant, etc., and inflates the bag when instructed by the airbag sensor assembly.

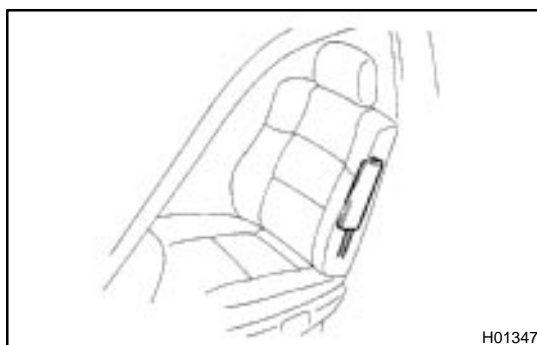

4. SIDE AIRBAG ASSEMBLY

The inflator and bag of the SRS side airbag are stored in the side airbag assembly and cannot be disassembled. The inflator contains a squib, igniter charge and gas generant, etc., and inflates the bag when instructed by the side airbag sensor assembly.

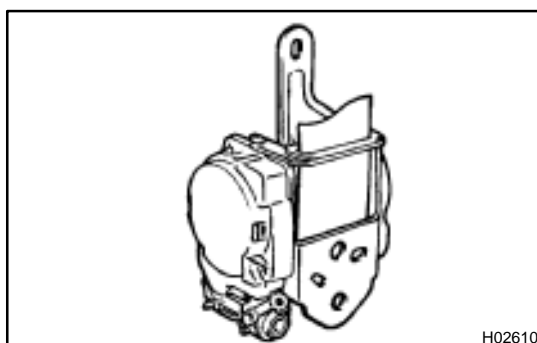

5. SEAT BELT PRETENSIONER

The seat belt pretensioner system is a component of the front seat outer belt. The pretensioner contains a squib, gas generant, wire, piston, etc., and operates in the event of a frontal collision.

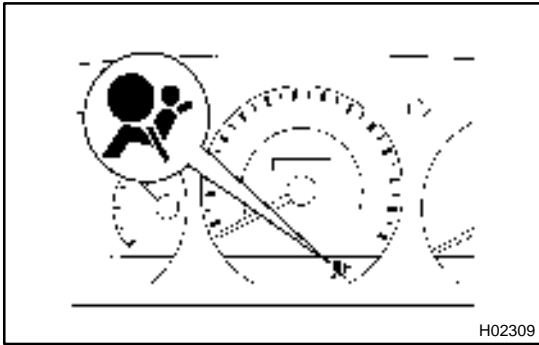

6. SRS WARNING LIGHT

The SRS warning light is located on the combination meter. It goes on to alert the driver of trouble in the system when a malfunction is detected in the airbag sensor assembly self-diagnosis. In normal operation conditions when the ignition switch is turned to the ACC or ON position, the light goes on for about 6 seconds and then goes off.

H02309

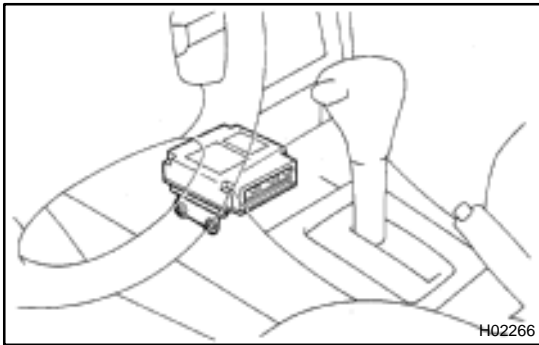

7. AIRBAG SENSOR ASSEMBLY

The airbag sensor assembly is mounted on the floor inside the lower center finish panel. The airbag sensor assembly consists of an airbag sensor, safing sensor, diagnosis circuit, ignition control and drive circuit, etc. It receives signals from the airbag sensor and judges whether the SRS must be activated or not.

H02266

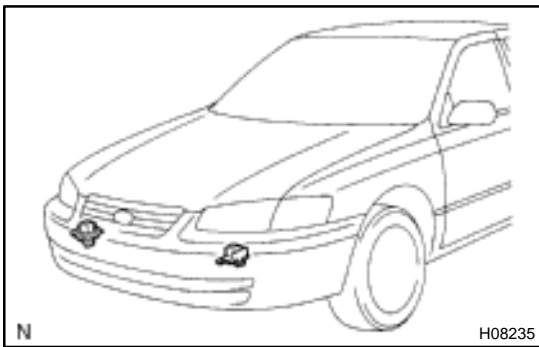

8. FRONT AIRBAG SENSOR

A front airbag sensor is mounted inside each of the side members. The sensor unit is a mechanical type. When the sensor detects deceleration force above a predetermined limit, contact is made in the sensor, sending a signal to the airbag sensor assembly. The sensor cannot be disassembled.

N

H08235

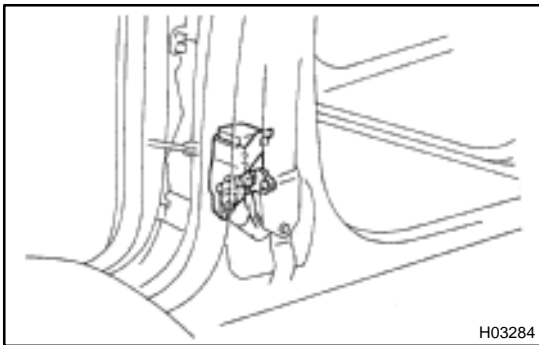

9. SIDE AIRBAG SENSOR ASSEMBLY

The side airbag sensor assembly is mounted in the LH and RH center pillars. The side airbag sensor assembly consists of a lateral deceleration sensor, safing sensor and diagnosis circuit, etc. It receives signals to the airbag sensor assembly to judge from the side airbag sensors whether the SRS side airbag must be activated or not.

H03284

**10. TMC made:
SRS CONNECTORS**

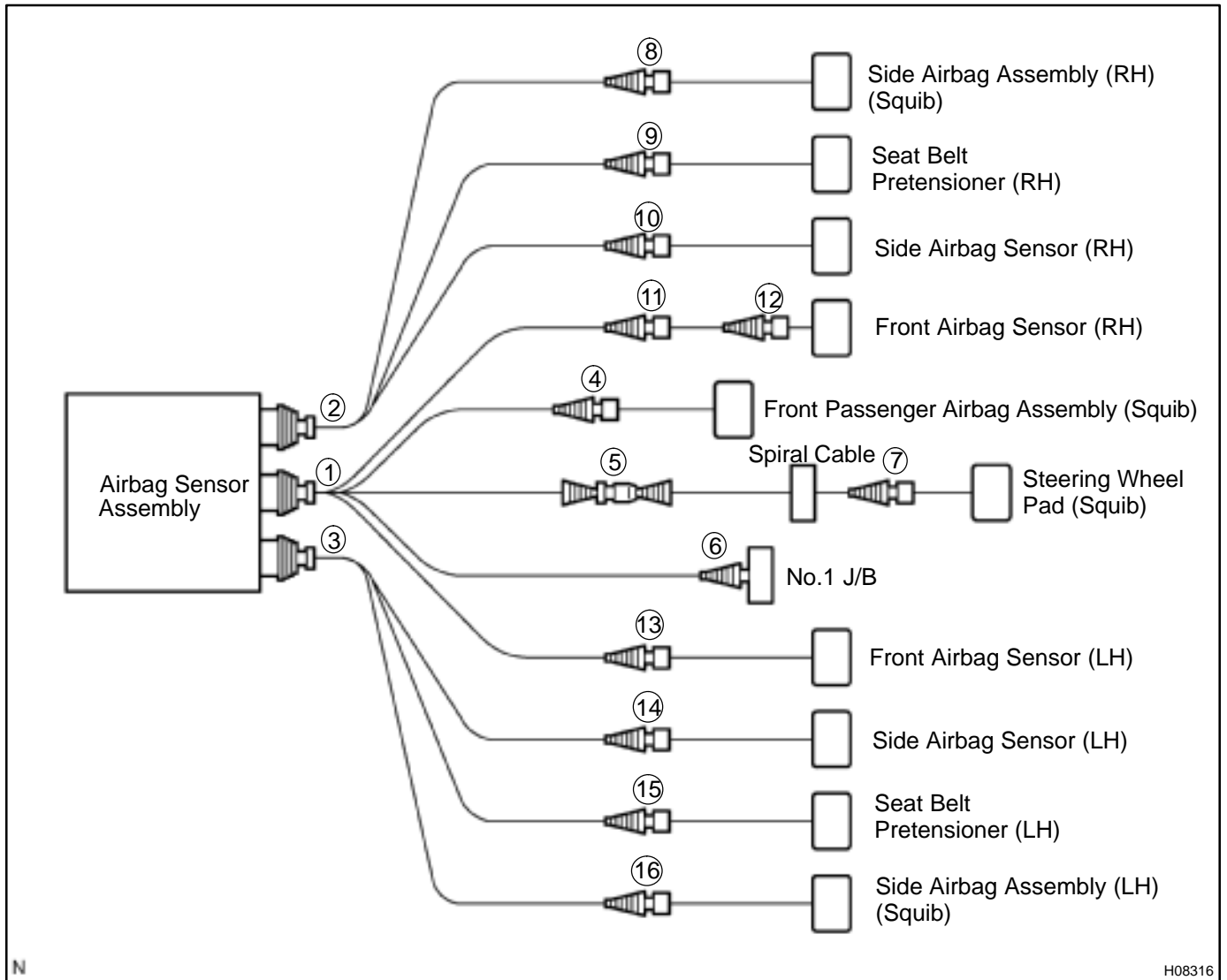

No.	Item	Application
(1)	Terminal Twin-Lock Mechanism	Connectors 1, 2, 3, 4, 5, 6, 7, 8, 9, 10, 11, 12, 13, 14, 15, 16
(2)	Airbag Activation Prevention Mechanism	Connectors 1, 2, 3, 4, 5, 7, 8, 9, 15, 16
(3)	Electrical Connection Check Mechanism	Connectors 1, 2, 3
(4)	Connector Twin-Lock Mechanism	Connectors 5, 6, 7

**11. TMMK made:
SRS CONNECTORS**

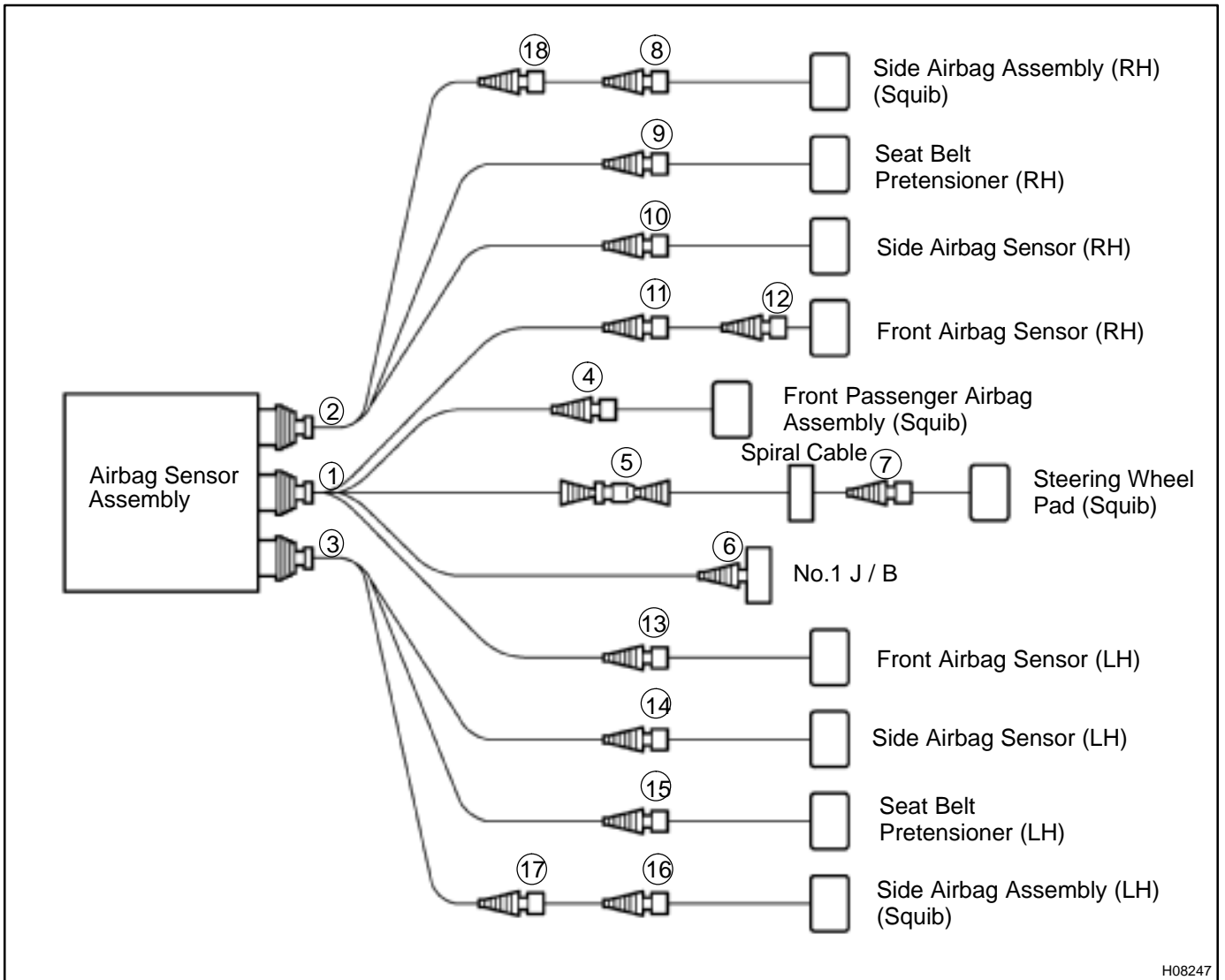

No.	Item	Application
(1)	Terminal Twin-Lock Mechanism	Connectors 1, 2, 3, 4, 5, 6, 7, 8, 9, 10, 11, 12, 13, 14, 15, 16, 17, 18
(2)	Airbag Activation Prevention Mechanism	Connectors 1, 2, 3, 4, 5, 7, 8, 9, 15, 16, 17, 18
(3)	Electrical Connection Check Mechanism	Connectors 1, 2, 3
(4)	Connector Twin-Lock Mechanism	Connectors 5, 6, 7

- (a) All connectors in the SRS are colored in yellow to distinguish them from other connectors. Connectors having special functions and specifically designed for the SRS are used in the locations shown on the previous page to ensure high reliability. These connectors use durable gold-plated terminals.

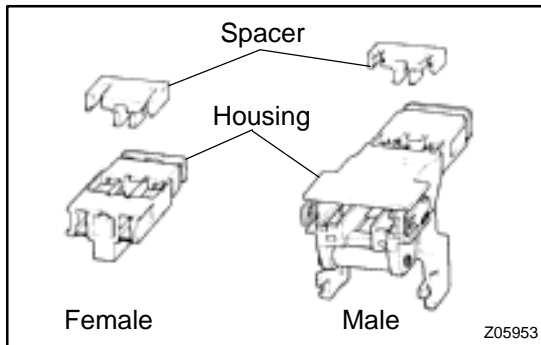

- (1) Terminal twin-lock mechanism
Each connector has a two-piece component consisting of a housing and a spacer. This design enables the terminal to be locked securely by two locking devices (the retainer and the lance) to prevent terminals from coming out.
- (2) Airbag activation prevention mechanism
Each connector contains a short spring plate. When the connector is disconnected, the short spring plate automatically connects positive (+) terminal and negative (-) terminal of the squib.

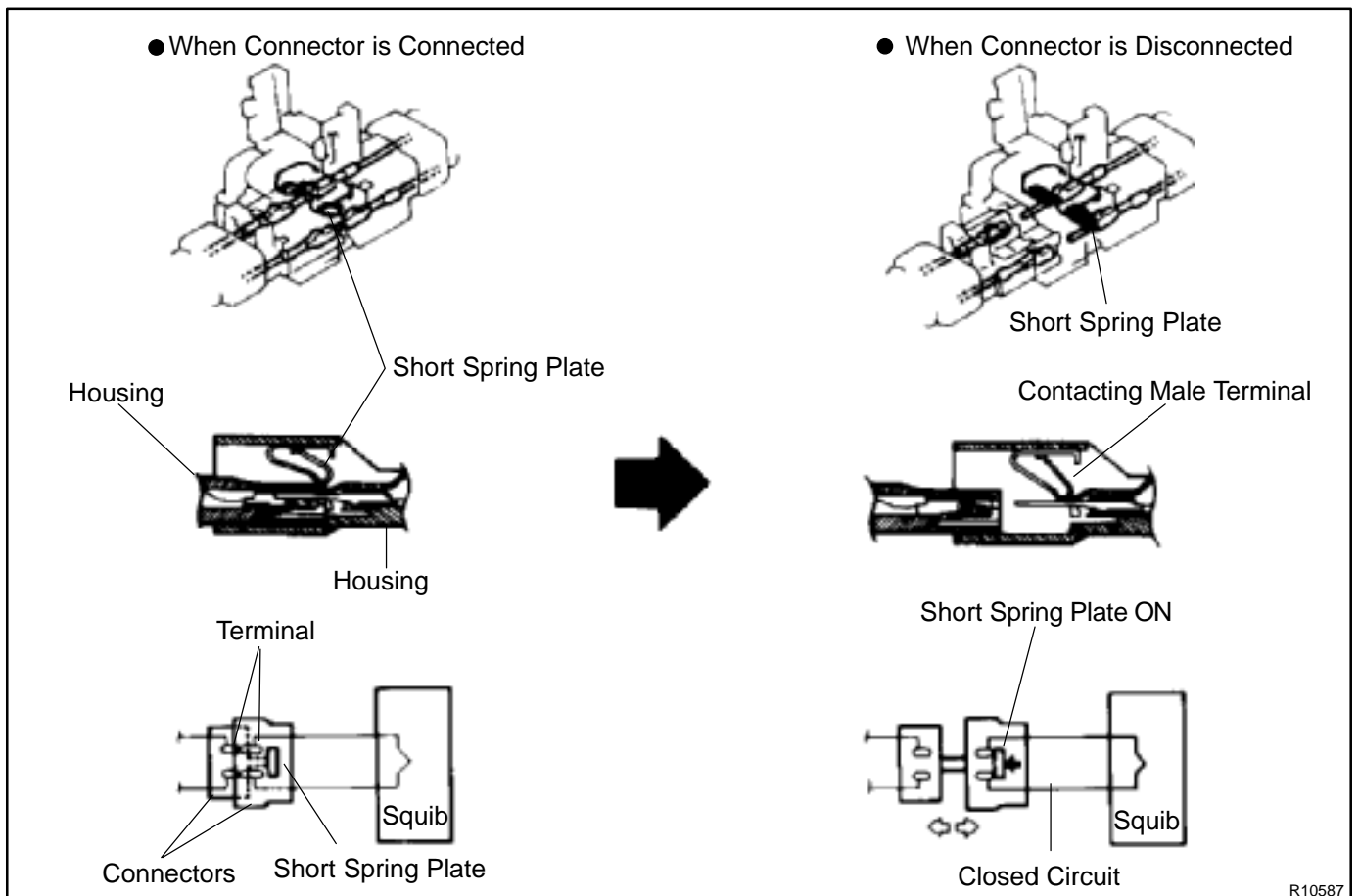

HINT:

The type of connector is shown in the diagram on the previous page.

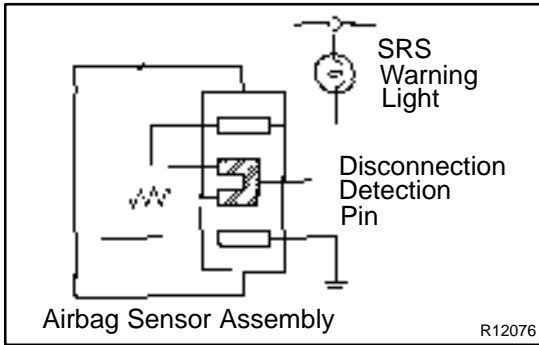

- (3) Electrical connection check mechanism
This mechanism electrically checks that connectors are connected correctly and completely. The electrical connection check mechanism is designed so that the disconnection detection pin connects with the diagnosis terminals when the connector housing lock is locked.

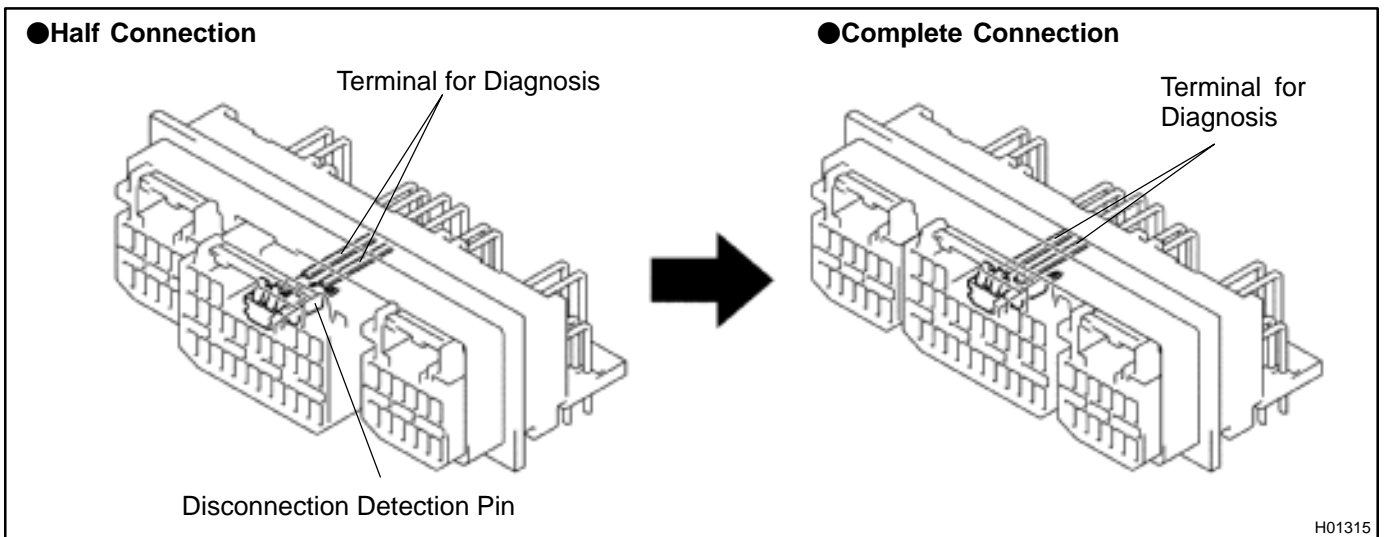

HINT:

The connectors shown in this illustration are connectors, "1", "2" and "3" in step 10 and 11.

- (4) Connector twin-lock mechanism
 With this mechanism connectors (male and female connectors) are locked by 2 locking devices to increase the connection reliability. If the primary lock is incomplete, ribs interfere and prevent the secondary lock.

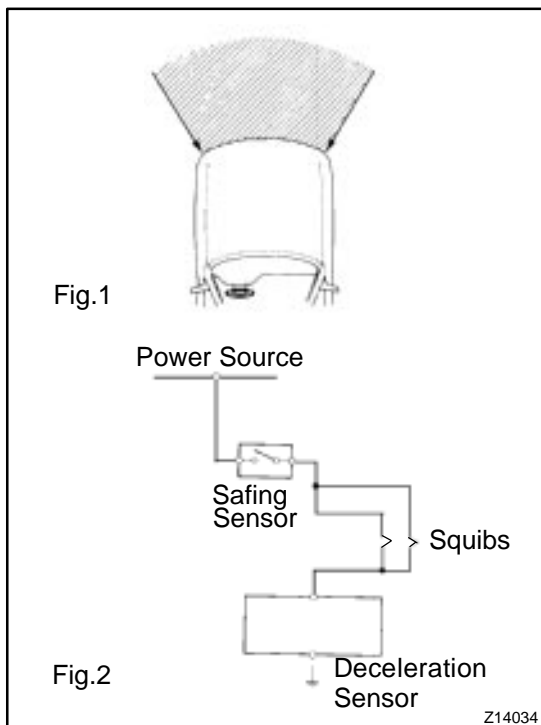
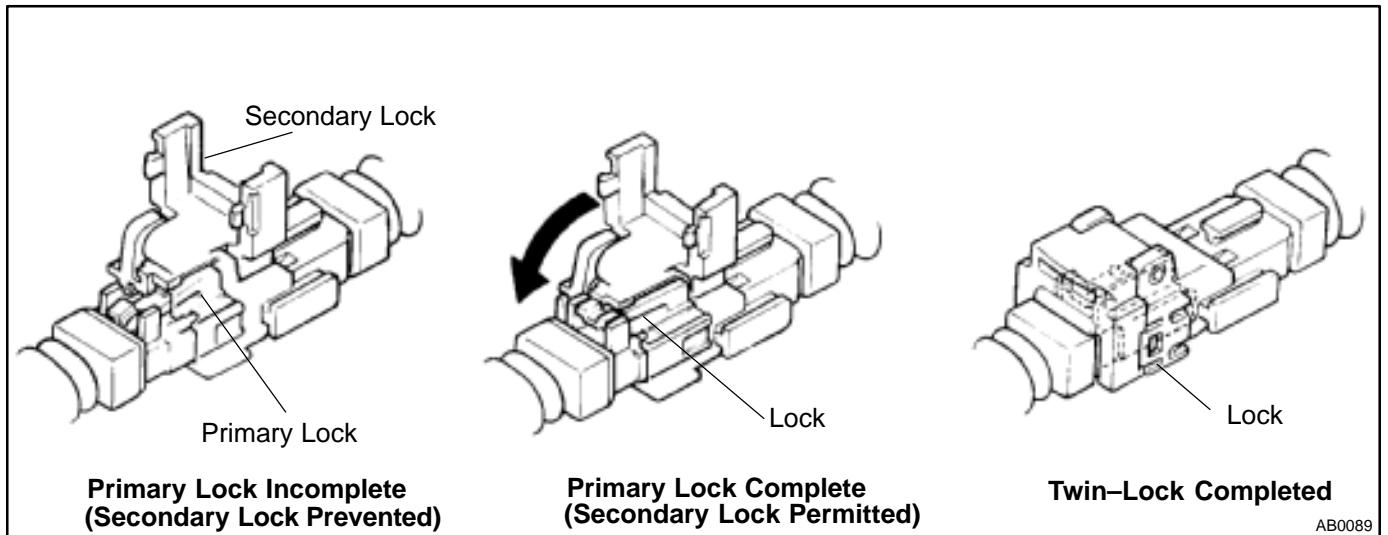

- (b) When the vehicle is involved in a frontal collision in the hatched area (Fig. 1) and the shock is larger than the predetermined level, the SRS is activated automatically. A safing sensor is designed to go on at a smaller deceleration rate than the airbag sensor. As illustrated in Fig. 2, ignition is caused when current flows to the squib, which happens when a safing sensor and the deceleration sensor go on simultaneously. When a deceleration force acts on the sensors, 2 squibs in the driver airbag and front passenger airbag ignite and generate gas. The gas discharging into the driver airbag and front passenger airbag rapidly increases the pressure inside the bags, breaking open the steering wheel pad and instrument panel door. Bag inflation then ends, and the bags deflate as the gas is discharged through discharge holes at the bag's rear or side.

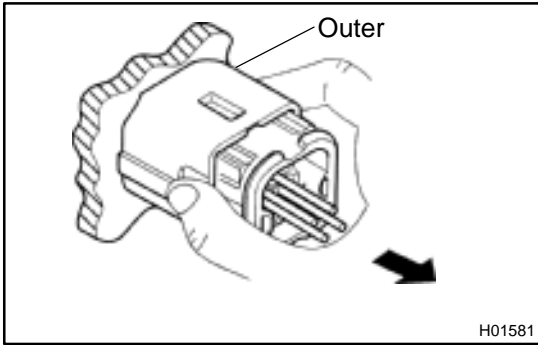

12. DISCONNECTION OF FRONT AIRBAG SENSOR AND SIDE AIRBAG SENSOR CONNECTOR

- (a) While holding both flank sides of the outer, slide the outer to the direction shown by an arrow.
- (b) Lock of the connectors is released, then disconnect the connectors.

HINT:

Make sure to hold both flank sides of the outer. If holding the top and bottom sides, it will obstruct disconnection.

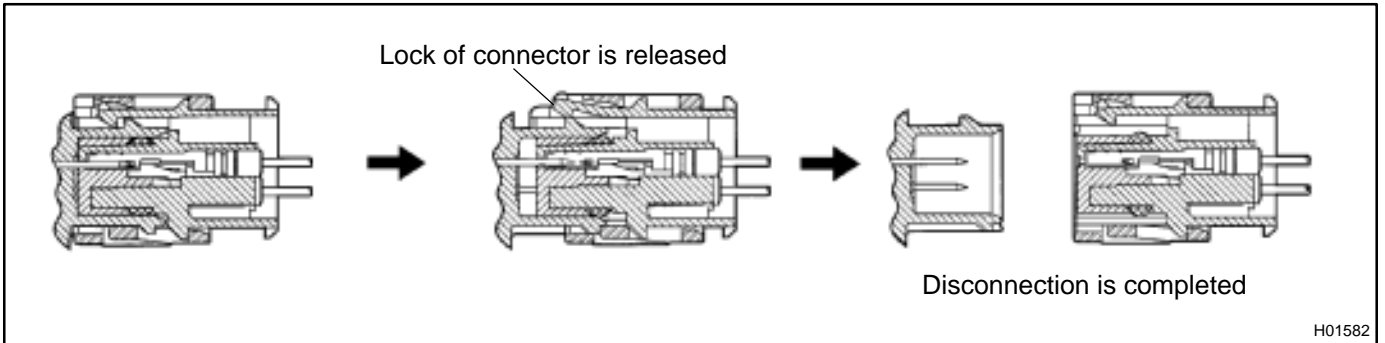

13. CONNECTION OF FRONT AIRBAG SENSOR AND SIDE AIRBAG SENSOR CONNECTOR

- (a) Align the male connector (of the side of sensor) and female connector in the same direction as shown in the illustration and fit in them without rubbing.
- (b) As they are fitted in, the outer slides rearward. Press it until the outer returns to its original position again.

If fitting stops half way, connectors will separate.

- (c) Make sure to insert until they are locked. After fitting in, pull them slightly to check that they are locked. (When locked, make sure that the outer returns to its original position and sound at the time of fitting in can be heard.)

HINT:

Do not fit in while holding the outer.

When fitting in, the outer slides. Do not touch it.

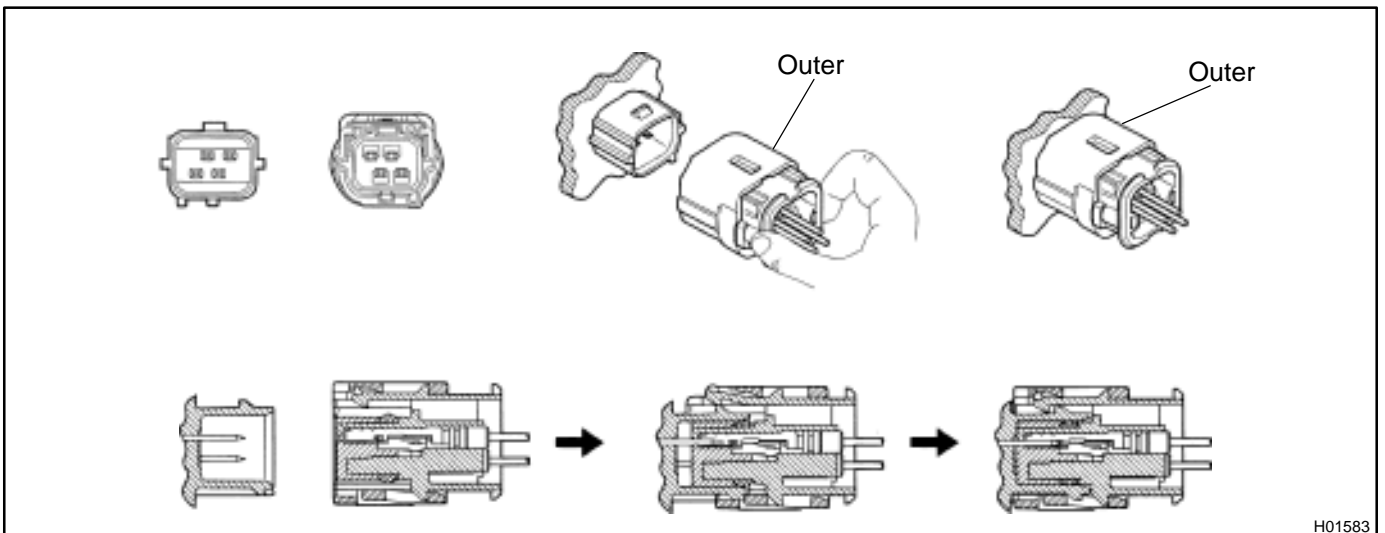

14. DISCONNECTION OF SIDE AIRBAG CONNECTOR

- (a) Place a finger on the slider.
- (b) Slide the slider to release lock.
- (c) Disconnect the connector.

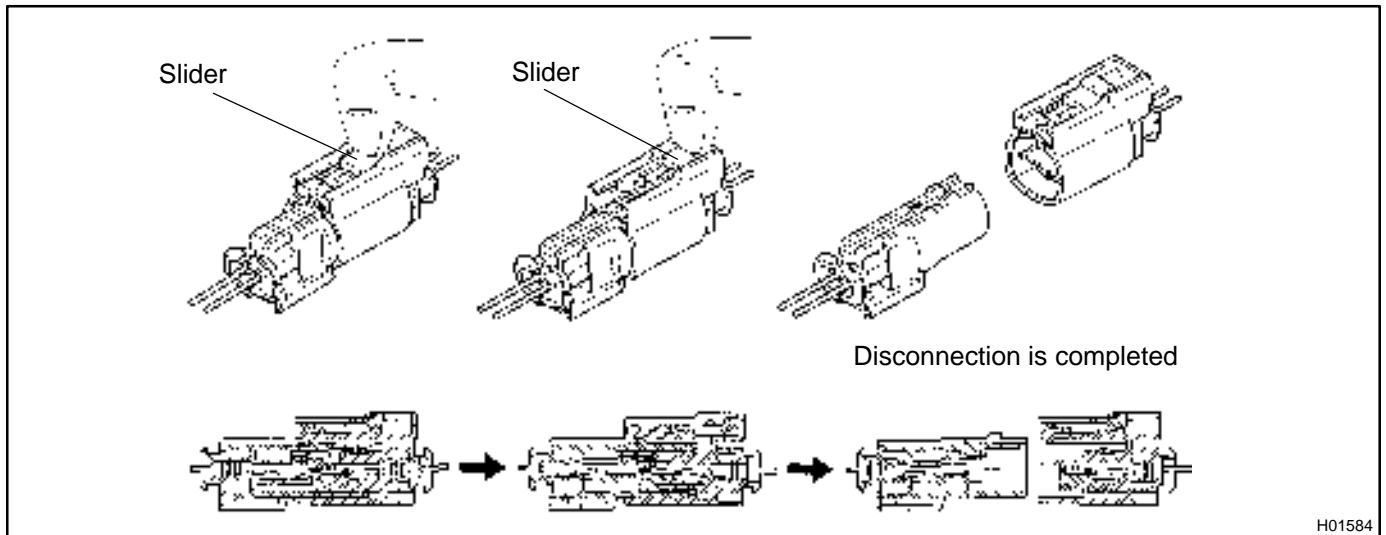

15. CONNECTION OF SIDE AIRBAG CONNECTOR

- (a) Align a lock part of male connector and a slider of female connector in the same direction as shown in the illustration, fit in them without rubbing.
- (b) Make sure to insert until they are locked. After fitting in pull them slightly to check that they are locked. (When locked, make sure that the outer returns to its original position and sound at the time of fitting in can be heard.)

HINT:

As the slider slides, do not touch it.

Be careful not to deform the release board. If the release board is deformed, replace it with a new one.

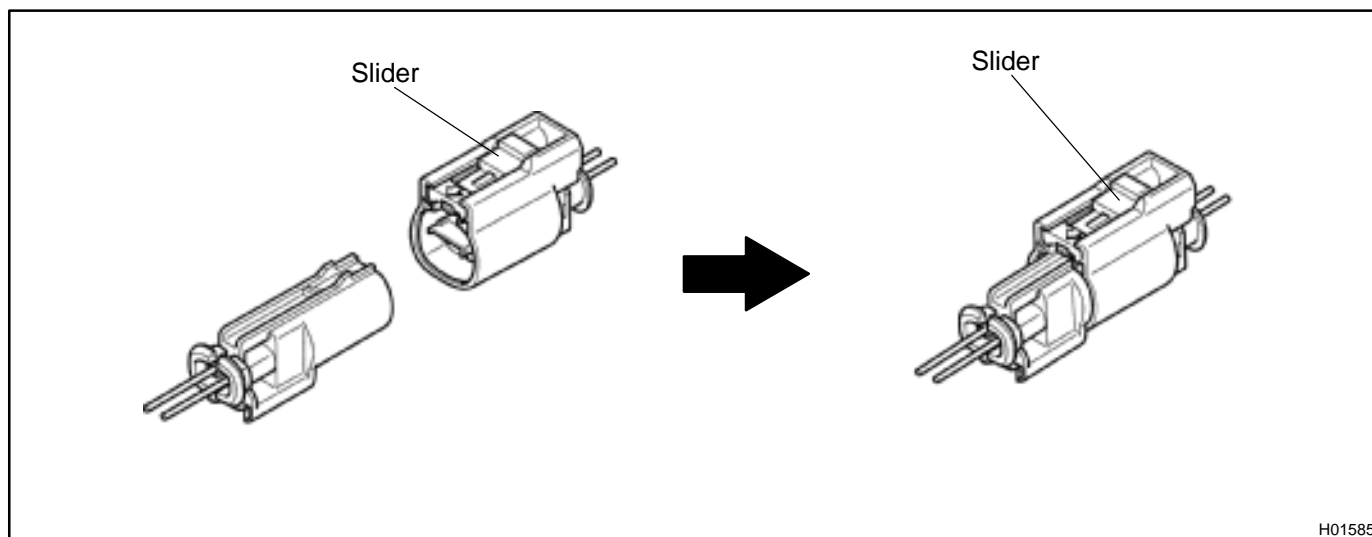

H01585

16. DISCONNECTION OF CONNECTORS FOR FRONT PASSENGER AIRBAG ASSEMBLY

- (a) Place a finger on the slider.
- (b) Slide the slider to release lock.
- (c) Disconnect the connector.

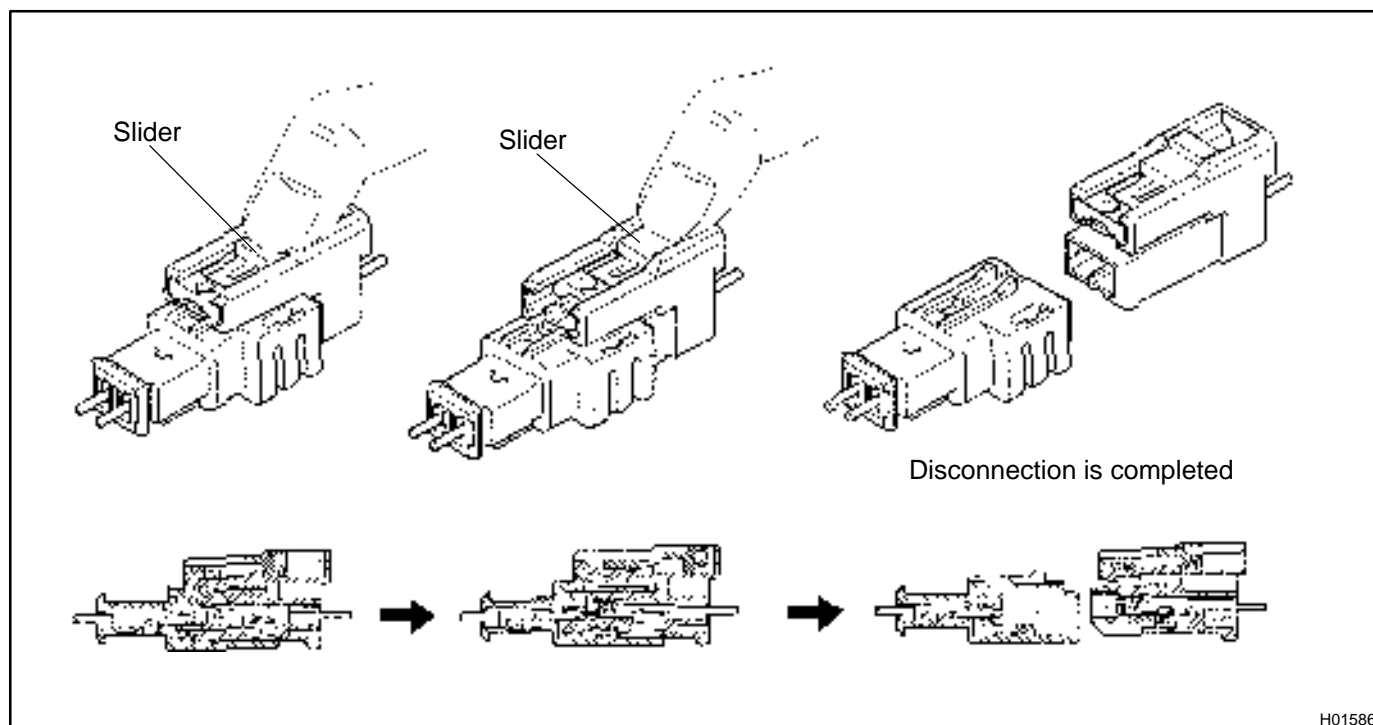

17. CONNECTION OF CONNECTORS FOR FRONT PASSENGER AIRBAG ASSEMBLY

- (a) Align a lock part of male connector and a slider of female connector in the same direction as shown in the illustration, fit in them without rubbing.
- (b) Make sure to insert until they are locked. After fitting in pull them slightly to check that they are locked. (When locked, make sure that the outer returns to its original position and sound at the time of fitting in can be heard.)

HINT:

As the slider slides, do not touch it.

Be careful not to deform the release board. If the release board is deformed, replace it with a new one.

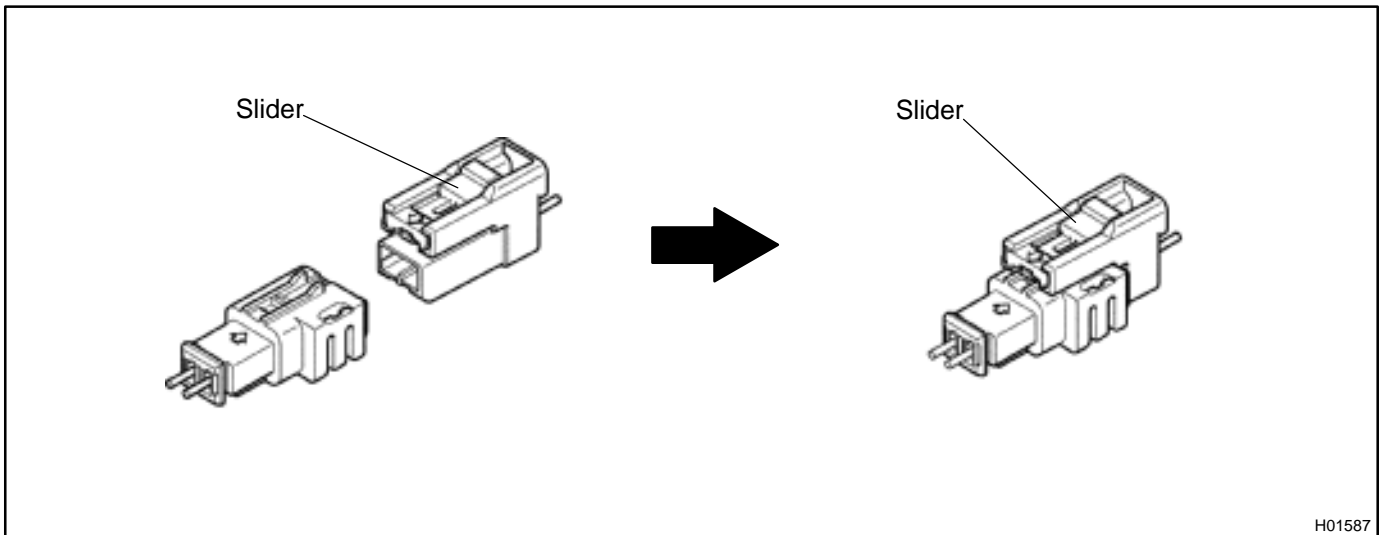

H01587

STEERING WHEEL PAD AND SPIRAL CABLE COMPONENTS

RS00Y-20

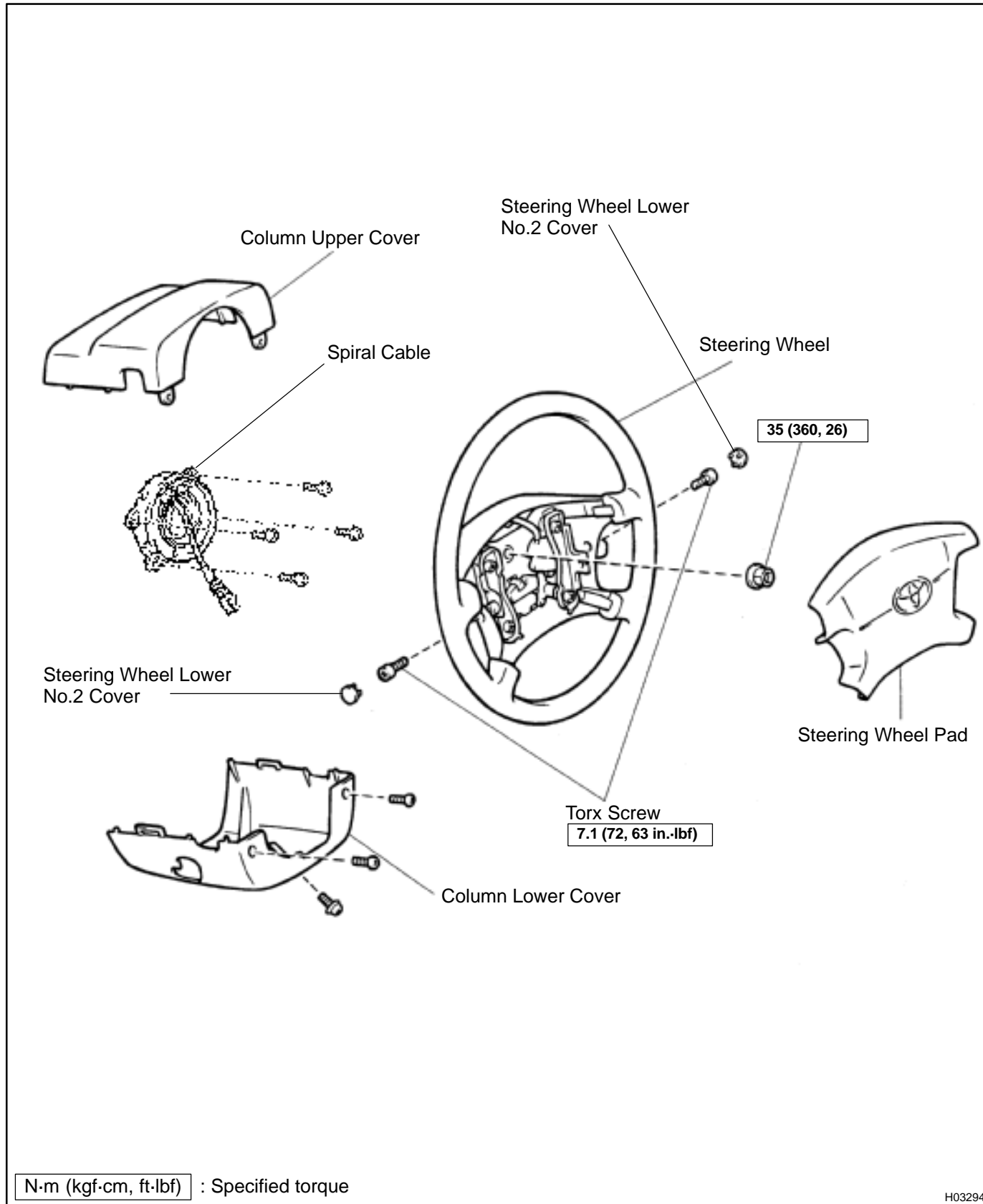

H03294

REMOVAL

HINT:

For step 1 to 4, refer to page [SR-11](#).

1. REMOVE STEERING WHEEL PAD
2. REMOVE STEERING WHEEL
3. REMOVE UPPER AND LOWER COLUMN COVERS
4. REMOVE SPIRAL CABLE



INSPECTION

1. VEHICLE NOT INVOLVED IN COLLISION

- (a) Do a diagnostic system check.
(See page [DI-626](#))
- (b) Do a visual check which includes the following items with the steering wheel pad (with airbag) installed in the vehicle.
Check cuts, minute cracks or marked discoloration on the steering wheel pad top surface and in the grooved portion.

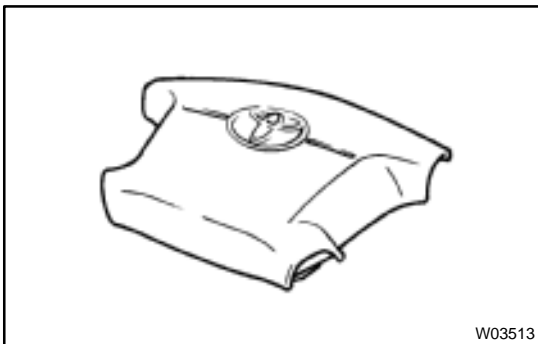

2. VEHICLE INVOLVED IN COLLISION AND AIRBAG IS NOT DEPLOYED

- (a) Do a diagnostic system check.
(See page [DI-626](#))
- (b) Do a visual check which includes the following items with the steering wheel pad (with airbag) removed from the vehicle.
 - Check cuts, minute cracks or marked discoloration on the steering wheel pad top surface and in the grooved portion.
 - Check cuts and cracks in wire harnesses, and chipping in connectors.
 - Check the deformation of the horn button contact plate on the steering wheel.

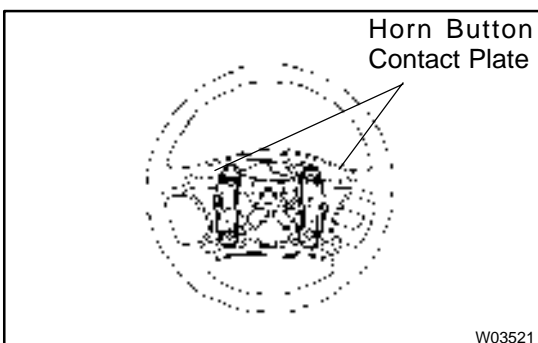

HINT:

- If the horn button contact plate of the steering wheel is deformed, never repair it. Always replace the steering wheel assembly with a new one.

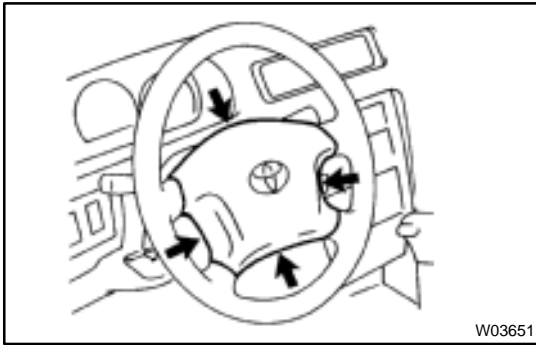

- There should be no interference between the steering wheel pad and steering wheel, and the clearance should be uniform all the way around when the new steering wheel pad is installed on the steering wheel.

CAUTION:

For removal and installation of the steering wheel pad, see page SR-11 and SR-16, and be sure to follow the correct procedure.

3. VEHICLE INVOLVED IN COLLISION AND AIRBAG IS DEPLOYED

- Do a diagnostic system check.
(See page DI-626)
- Do a visual check which includes the following items with the steering wheel pad (with airbag) removed from the vehicle.
 - Check the deformation on the horn button contact plate of the steering wheel.
 - Check the damage on the spiral cable connector and wire harness.

HINT:

- If the horn button contact plate of the steering wheel is deformed, never repair it. Always replace the steering wheel assembly with a new one.
- There should be no interference between the steering wheel pad and steering wheel, and the clearance should be uniform all the way around when the new steering wheel pad is installed on the steering wheel.

DISPOSAL

HINT:

When scrapping vehicle equipped with an SRS or disposing of a steering wheel pad (with airbag), always first deploy the airbag in accordance with the procedure described below. If any abnormality occurs with the airbag deployment, contact the SERVICE DEPT. of TOYOTA MOTOR SALES, U.S.A., INC. When disposing of a steering wheel pad with an airbag deployed in a collision, follow the same procedure given in step 1-(d) in "DISPOSAL".

CAUTION:

- Never dispose of a steering wheel pad which has an undeployed airbag.
- The airbag produces a sizeable exploding sound when it deploys, so perform the operation out-of-doors and where it will not create a nuisance to nearby residents.



- When deploying the airbag, always use the specified SST (SRS Airbag Deployment Tool). Perform the operation in a place away from electrical noise.
SST 09082-00700
- When deploying an airbag, perform the operation at least 10 m (33 ft) away from the steering wheel pad.
- The steering wheel pad is very hot when the airbag is deployed, so leave it alone for at least 30 minutes after deployment.
- Use gloves and safety glasses when handling a steering wheel pad with the deployed airbag.
- Always wash your hands with water after completing the operation.
- Do not apply water, etc. to a steering wheel pad with the deployed airbag.

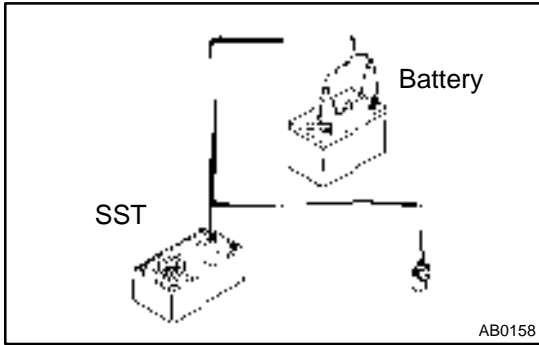

AB0158

1. AIRBAG DEPLOYMENT WHEN SCRAPPING VEHICLE

HINT:

Have a battery ready as the power source to deploy the airbag.



AB0152

(a) Check functioning of the SST.

CAUTION:

When deploying the airbag, always use the specified SST: SRS Airbag Deployment Tool.

SST 09082-00700

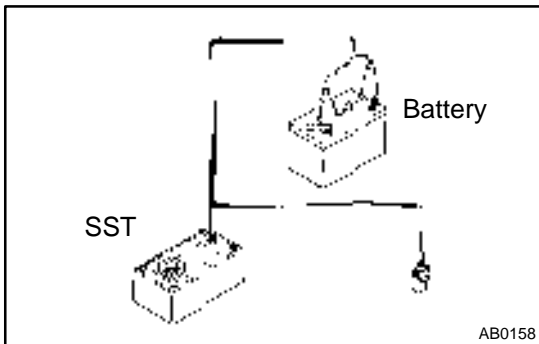

AB0158

(1) Connect the SST to the battery.

Connect the red clip of the SST to the battery positive (+) terminal and the black clip to the battery negative (-) terminal.

HINT:

Do not connect the yellow connector which will be connected with the supplemental restraint system.

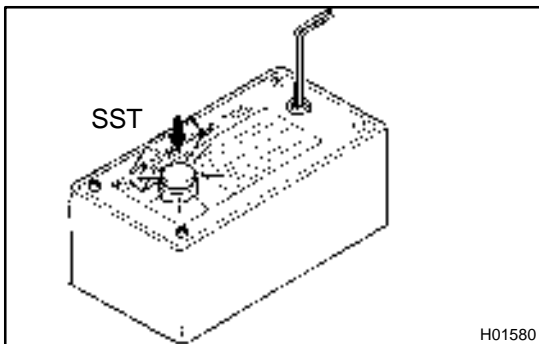

H01580

(2) Check functioning of the SST.

Press the SST activation switch, and check that the LED of the SST activation switch lights up.

CAUTION:

If the LED lights up when the activation switch is not being pressed, SST malfunction is probable, so definitely do not use the SST.

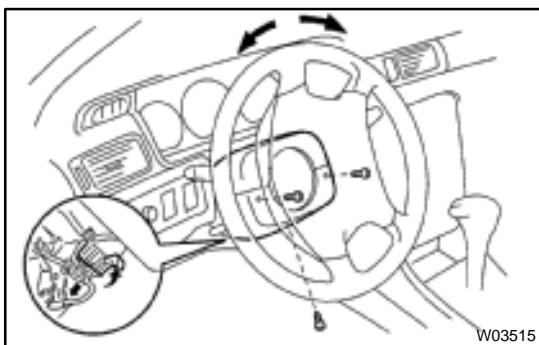

W03515

(b) Install the SST.

CAUTION:

Check that there is no looseness in the steering wheel and steering wheel pad.

(1) Remove the steering column lower cover.

Remove the 3 screws and steering column lower cover as shown in the illustration.

(2) Disconnect the airbag connector of the spiral cable.

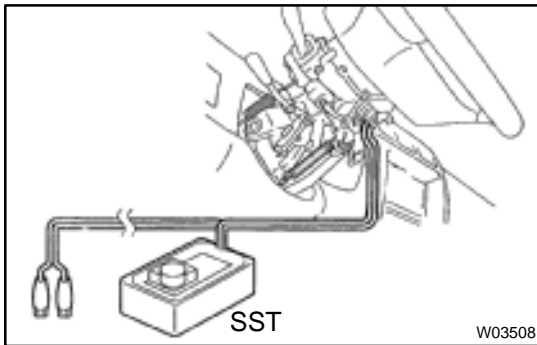

- (3) Connect the SST connector to the airbag connector of the spiral cable.

SST 09082-00700

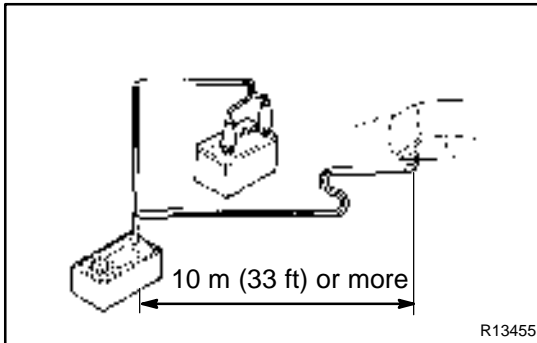

- (4) Move the SST at least 10 m (33 ft) away from the front of the vehicle.

- (5) Close all the doors and windows of the vehicle.

NOTICE:

Take care not to damage the SST wire harness.

- (6) Connect the SST red clip to the battery positive (+) terminal and the black clip to the negative (-) terminal.

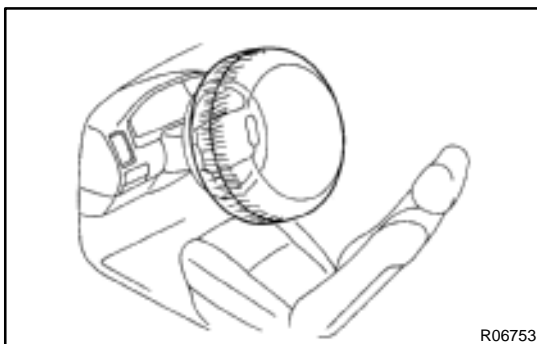

- (c) Deploy the airbag.

- (1) Confirm that no one is inside the vehicle or within 10 m (33 ft) area around the vehicle.

- (2) Press the SST activation switch and deploy the airbag.

HINT:

The airbag deploys simultaneously as the LED of the SST activation switch lights up.

- (d) Dispose of steering wheel pad (with airbag).

CAUTION:

- The steering wheel pad is very hot when the airbag is deployed, so leave it alone for at least 30 minutes after deployment.
- Use gloves and safety glasses when handling a steering wheel pad with the deployed airbag.
- Always wash your hands with water after completing the operation.
- Do not apply water, etc. to a steering wheel pad with the deployed airbag.

- (1) When scrapping a vehicle, deploy the airbag and scrap the vehicle with the steering wheel pad still installed.

- (2) When moving a vehicle for scrapping which has a steering wheel pad with deployed airbag, use gloves and safety glasses.

2. DEPLOYMENT WHEN DISPOSING OF STEERING WHEEL PAD ONLY

NOTICE:

- When disposing of the steering wheel pad (with airbag) only, never use the customers vehicle to deploy the airbag.
- Be sure to follow the procedure given below when deploying the airbag.

HINT:

Have a battery ready as the power source to deploy the airbag.

(a) Remove the steering wheel pad.

(See page [SR-11](#))

CAUTION:

When storing the steering wheel pad, keep the upper surface of the pad facing upward.

(b) Remove the steering wheel pad connector.

Remove the connector on the rear surface of the steering wheel pad from the bracket.

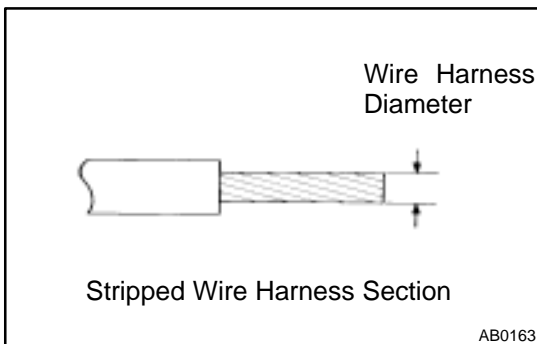
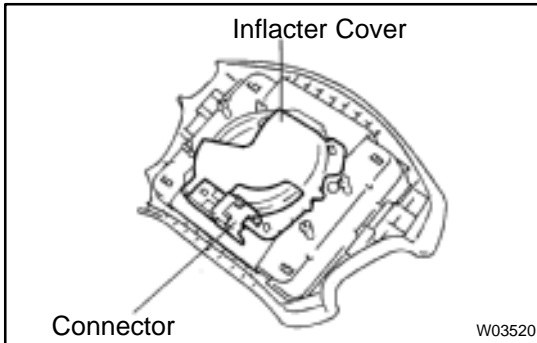

(c) Using a service-purpose wire harness, tie down the steering wheel pad to the disc wheel.

Wire harness: Stripped wire harness section 1.25 mm² or more (0.0019 in². or more).

CAUTION:

If a wire harness which is too thin or some other thing is used to tie down the steering wheel pad, it may be snapped by the shock when the airbag is deployed. This is highly dangerous. Always use a wire harness for vehicle use which is at least 1.25 mm² (0.0019 in²).

HINT:

To calculate the square of the stripped wire harness section:

$$\text{Square} = 3.14 \times (\text{Diameter})^2 \text{ divided by } 4$$

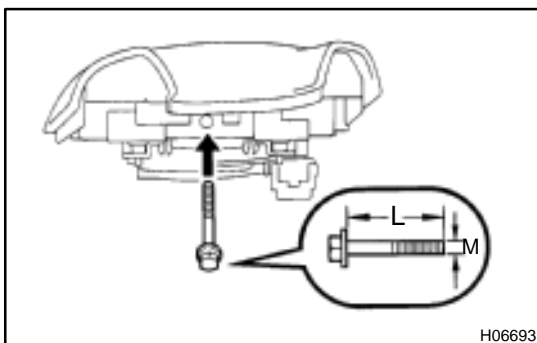

(1) Install the 2 bolts with washers in the 2 bolt holes in the steering wheel pad.

Bolt:

L: 35.0 mm (1.387 in.)

M: 6.0 mm (0.236 in.)

Pitch: 1.0 mm (0.039 in.)

NOTICE:

- Tighten the bolts by hand until the bolts become difficult to turn.
- Do not tighten the bolts too much.

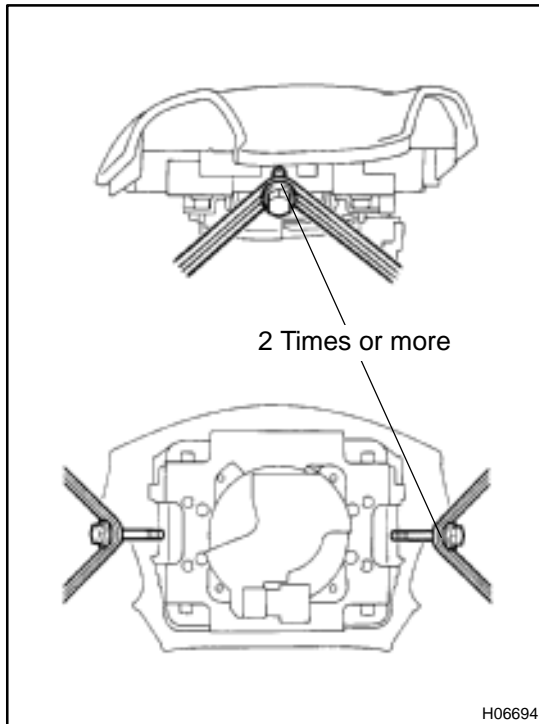

- (2) Using 3 wire harnesses, wind the wire harness at least 2 times each around the bolts installed on the left and right sides of the steering wheel pad.

CAUTION:

- **Tightly wind the wire harness around the bolts so that there is no slack.**
- **If there is slack in the wire harness, the steering wheel pad may come loose due to the shock when the airbag is deployed. This is highly dangerous.**

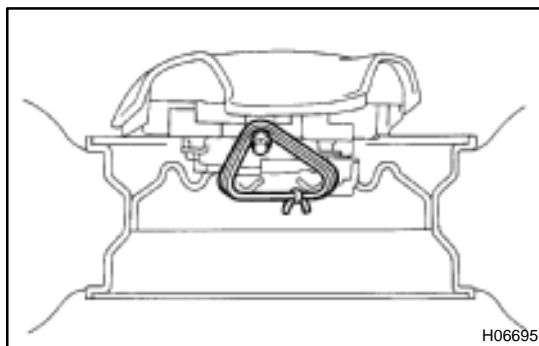

- (3) Face the upper surface of the steering wheel pad upward. Separately tie the left and right sides of the steering wheel pad to the disc wheel through the hub nut holes. Position the steering wheel pad connector so that it hangs downward through a hub hole in the disc wheel.

CAUTION:

- **Make sure that the wire harness is tight. It is very dangerous when looseness in the wire harness results in the steering wheel pad coming free through the shock from the airbag deploying.**
- **Always tie down the steering wheel pad with the pad side facing upward. It is very dangerous if the steering wheel pad is tied down with the metal surface facing upward as the wire harness will be cut by the shock from the airbag deploying and the steering wheel pad will be thrown into the air.**

NOTICE:

The disc wheel will be marked by airbag deployment, so when disposing of the airbag use a redundant disc wheel.

- (d) Check functioning of the SST. (See step 1-(a))
SST 09082-00700

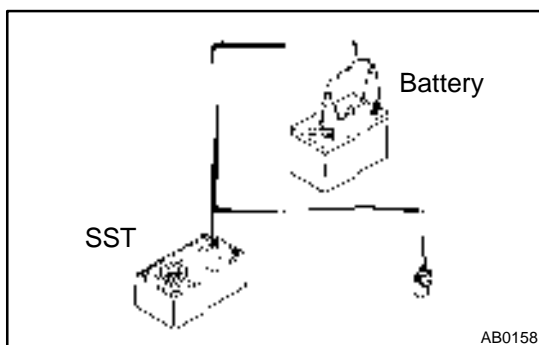

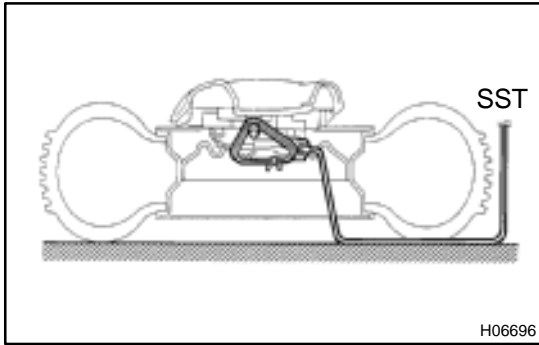

(e) Install the SST.

CAUTION:

Place the disc wheel on the level ground.

- (1) Connect the connector of SST to the steering wheel pad connector.

SST 09082-00700

NOTICE:

To avoid damaging the SST connector and wire harness, do not lock the secondary lock of the twin lock. Also, secure some slack for the SST wire harness inside the disc wheel.

- (2) Move the SST to at least 10 m (33 ft) away from the steering wheel pad tied down on the disc wheel.

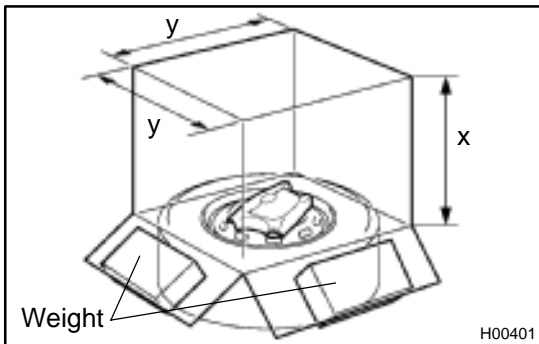

(f) Cover the steering wheel pad with a cardboard box or tires.

- Covering method using a cardboard box:
Cover the steering wheel pad with the cardboard box and weight the cardboard box down in 4 places with at least 190 N (20 kg, 44 lb).

Size of cardboard box:

Must exceed the following dimensions:

x= 460 mm (18.11 in.)

When dimension of the cardboard box exceeds the diameter of the disc wheel with tire to which the steering wheel pad is tied

x= 460 mm (18.11 in.) + width of tire

y= 650 mm (25.59 in.)

NOTICE:

If a cardboard box smaller than the specified size is used, the cardboard box will be broken by the shock from the air-bag deployment.

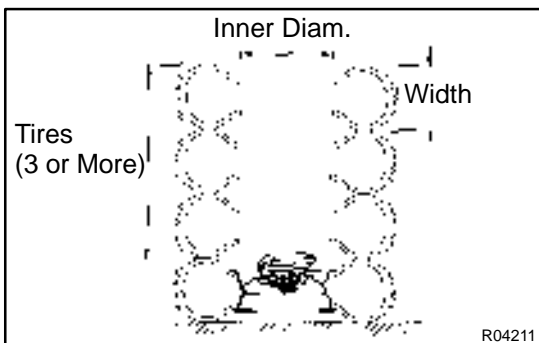

- Covering method using tires:
Place at least 3 tires without disc wheel on top of the disc wheel with tire to which the steering wheel pad is tied.

Tire size: Must exceed the following dimensions–

Width: 185 mm (7.87 in.)

Inner diameter: 360 mm (14.17 in.)

CAUTION:

Do not use tires with disc wheels.

NOTICE:

The tires may be marked by the airbag deployment, so use the redundant tires.

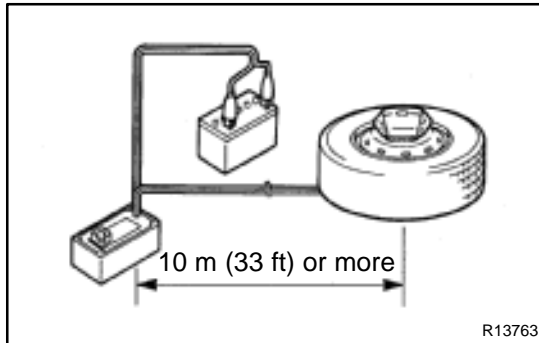

- (g) Deploy the airbag.
- (1) Connect the SST red clip to the battery positive (+) terminal and the black clip to the battery negative (-) terminal.
 - (2) Check that no one is within 10 m (33 ft) area around the disc wheel which the steering wheel pad is tied to.
 - (3) Press the SST activation switch and deploy the airbag.

HINT:

The airbag deploys simultaneously as the LED of the SST activation switch lights up.



- (h) Dispose of the steering wheel pad (with airbag).

CAUTION:

- The steering wheel pad is very hot when the airbag is deployed, so leave it alone for at least 30 minutes after deployment.
- Use gloves and safety glasses when handling a steering wheel pad with deployed airbag.
- Always wash your hands with water after completing the operation.
- Do not apply water, etc. to a steering wheel pad with deployed airbag.

- (1) Remove the steering wheel pad from the disc wheel.
- (2) Place the steering wheel pad in a vinyl bag, tie the end tightly and dispose of it in the same way as other general parts disposal.

REPLACEMENT

REPLACEMENT REQUIREMENTS

In the following cases, replace the steering wheel pad, steering wheel or spiral cable.

Case	Replacing part
If the airbag has been deployed.	Steering wheel pad
If the steering wheel pad has been found to be faulty in troubleshooting.	Steering wheel pad
If the spiral cable has been found to be faulty in troubleshooting.	Spiral cable
If the steering wheel pad has been found to be faulty during checking items. (See page RS-16)	Steering wheel pad
If the steering wheel has been found to be faulty during checking items. (See page RS-16)	Steering wheel
If the spiral cable has been found to be faulty during checking items. (See page RS-16)	Spiral cable
If the steering wheel pad has been dropped.	Steering wheel pad

CAUTION:

For removal and installation of the steering wheel pad, see page [SR-11](#) and [SR-16](#). Be sure to follow the correct procedure.

INSTALLATION

HINT:

For step 1 to 4, refer to page [SR-16](#).

1. **INSTALL SPIRAL CABLE**
2. **INSTALL UPPER AND LOWER COLUMN COVERS**
3. **INSTALL STEERING WHEEL**
4. **INSTALL STEERING WHEEL PAD**

FRONT PASSENGER AIRBAG ASSEMBLY COMPONENTS

RS014-21

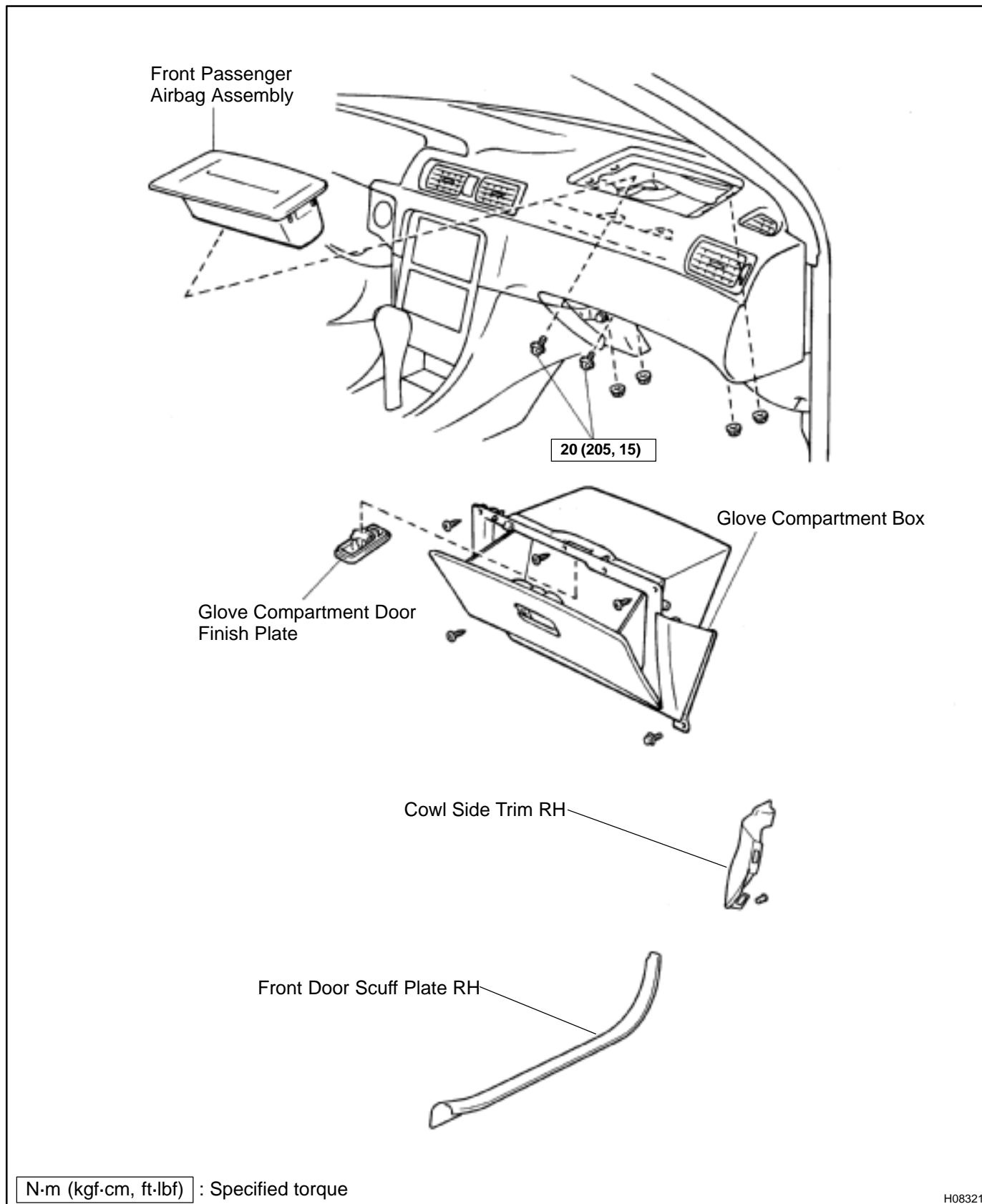

REMOVAL

NOTICE:

- If the wiring connector of the SRS is disconnected and the ignition switch is in ON or ACC position, DTCs will be recorded.
- Never use the airbag parts from another vehicle. When replacing parts, replace them with new parts.

HINT:

For step 2 to 4, refer to page [BO-75](#).

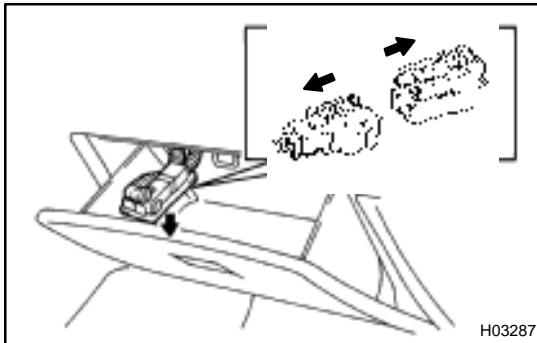

1. DISCONNECT AIRBAG CONNECTOR

- (a) Remove the glove compartment door finish plate inside the glove compartment box.

NOTICE:

When handling the airbag connector, take care not to damage the airbag wire harness.

- (b) Pull up the connector.
- (c) Disconnect the front passenger airbag connector.

2. REMOVE FRONT DOOR SCUFF PLATE

3. REMOVE COWL SIDE TRIM

4. REMOVE GLOVE COMPARTMENT BOX

5. REMOVE FRONT PASSENGER AIRBAG ASSEMBLY

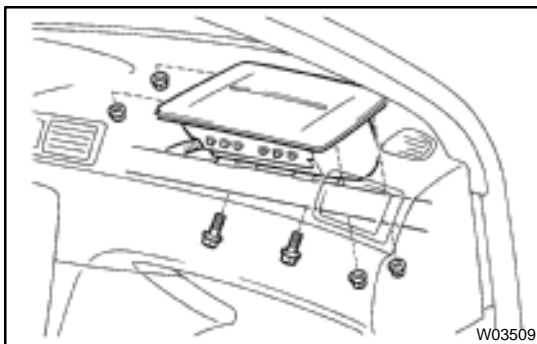

Remove the 2 bolts, 4 nuts and front passenger airbag assembly.

CAUTION:

- Do not store the front passenger airbag assembly with the airbag deployment side facing downward.
- Never disassemble the front passenger airbag assembly.

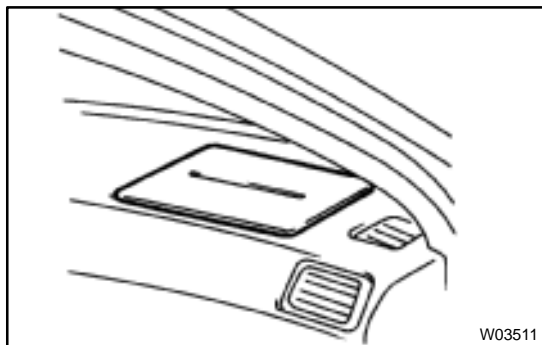

INSPECTION

1. VEHICLE NOT INVOLVED IN COLLISION

- (a) Do a diagnostic system check.
(See page [DI-626](#))
- (b) Do a visual check which includes the following items with the front passenger airbag assembly installed in the vehicle.
Check cuts, minute cracks or marked discoloration on the front passenger airbag assembly and instrument panel.

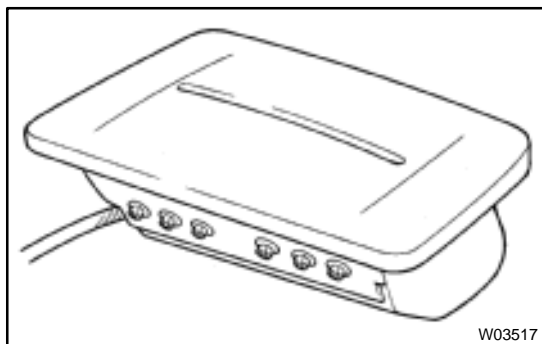

2. VEHICLE INVOLVED IN COLLISION AND AIRBAG IS NOT DEPLOYED

- (a) Do a diagnostic system check.
(See page [DI-626](#))
- (b) Do a visual check which includes the following items with the front passenger airbag assembly removed from the vehicle.
 - Check cuts, minute cracks or marked discoloration on the front passenger airbag assembly.
 - Check cuts and cracks in wire harnesses, and for chipping in connectors.
 - Check the deformation or cracks on the instrument panel and instrument panel reinforcement.

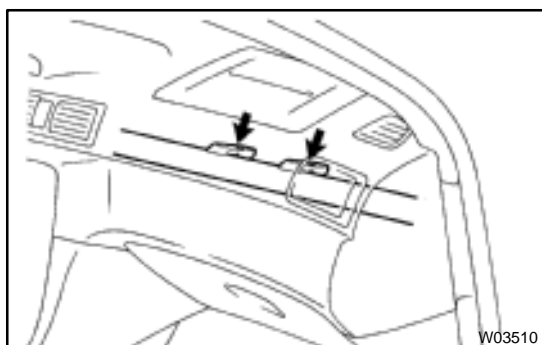

HINT:

- If the instrument panel or instrument panel reinforcement is deformed or cracked, never repair it. Always replace it with a new one.

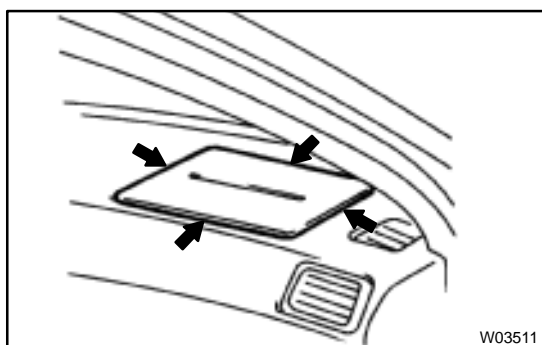

- There should be no interference between the instrument panel and the front passenger airbag assembly.

CAUTION:

For removal and installation of the front passenger airbag assembly, see page [RS-28](#) and [RS-38](#), and be sure to follow the correct procedure.

3. VEHICLE INVOLVED IN COLLISION AND AIRBAG IS DEPLOYED

- (a) Do a diagnostic system check.
(See page [DI-626](#))
- (b) Do a visual check which includes the following items with the front passenger airbag assembly removed from the vehicle.
 - Check the deformation or cracks on the instrument panel and instrument panel reinforcement.
 - Check the damage on the connector and wire harness.

HINT:

If the instrument panel or instrument panel reinforcement is deformed or cracked, never repair it. Always replace it with a new one.

DISPOSAL

HINT:

When scrapping vehicle equipped with an SRS or disposing of a front passenger airbag assembly, always first deploy the airbag in accordance with the procedure described below. If any abnormality occurs with the airbag deployment, contact the SERVICE DEPT. of TOYOTA MOTOR SALES, U.S.A., INC.

When disposing of a front passenger airbag assembly with an airbag deployed in a collision, follow the same procedure given in step 1–(e) in "DISPOSAL".

CAUTION:

- Never dispose of a front passenger airbag assembly which has an undeployed airbag.
- The airbag produces a sizeable exploding sound when it deploys, so perform the operation out-of-doors and where it will not create a nuisance to nearby residents.



- When deploying the airbag, always use the specified SST (SRS Airbag Deployment Tool). Perform the operation in a place away from electrical noise.
SST 09082-00700
- When deploying an airbag, perform the operation at least 10 m (33 ft) away from the front passenger airbag assembly.
- The front passenger airbag assembly is very hot when the airbag is deployed, so leave it alone for at least 30 minutes after deployment.
- Use gloves and safety glasses when handling a front passenger airbag assembly with deployed airbag.
- Always wash your hands with water after completing the operation.
- Do not apply water, etc. to a front passenger airbag assembly with deployed airbag.

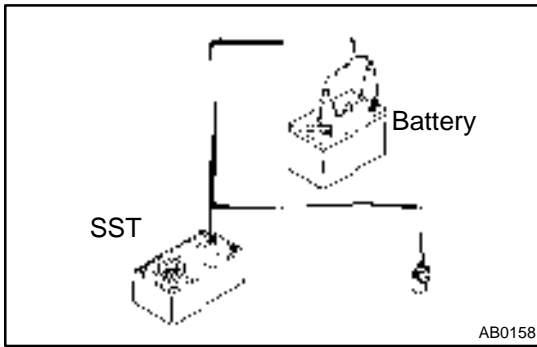

1. AIRBAG DEPLOYMENT WHEN SCRAPPING VEHICLE

HINT:

Have a battery ready as the power source to deploy the airbag.

- (a) Check functioning of the SST. (See page RS-18)
SST 09082-00700

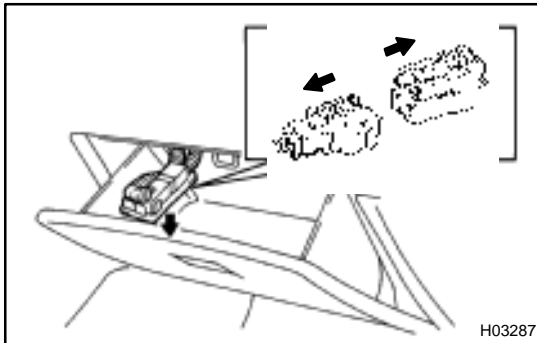

- (b) Disconnect the airbag connector.
(1) Remove the lower instrument cover inside the No.2 under cover.

NOTICE:

When handling the airbag connector, take care not to damage the airbag wire harness.

- (2) Pull up the connector.
(3) Disconnect the airbag connector.

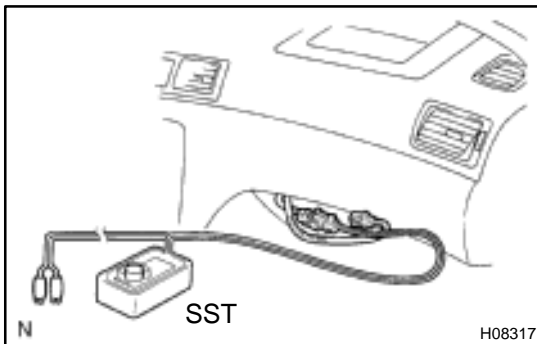

- (c) Install the SST.
(1) Connect the connector of 2 SST to the front passenger airbag assembly connector.
SST 09082-00700, 09082-00760

NOTICE:

To avoid damaging the SST connector and wire harness, do not lock the secondary lock of the twin lock.

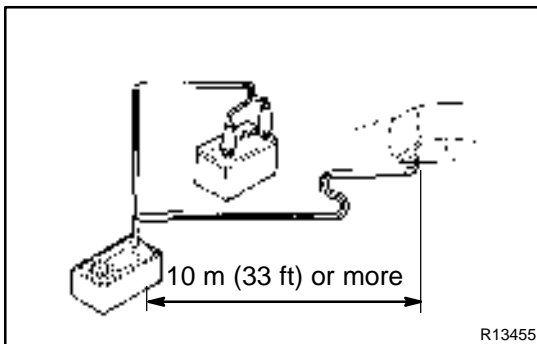

- (2) Move the SST to at least 10 m (33 ft) away from the front of the vehicle.
(3) Close all the doors and windows of the vehicle.

NOTICE:

Take care not to damage the SST wire harness.

- (4) Connect the SST red clip to the battery positive (+) terminal and the black clip to the negative (-) terminal.

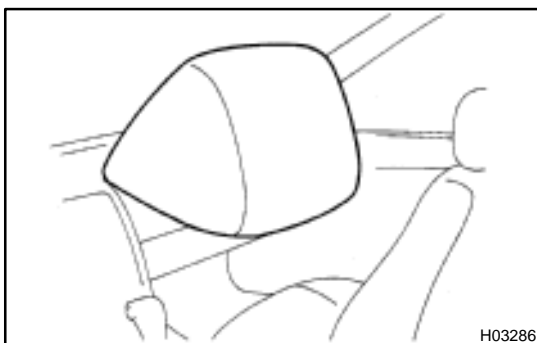

- (d) Deploy the airbag.
(1) Check that no one is inside the vehicle or within 10 m (33 ft) area around the vehicle.
(2) Press the SST activation switch and deploy the airbag.

HINT:

The airbag deploys simultaneously as the LED of the SST activation switch lights up.

- (e) Dispose of the front passenger airbag assembly.

CAUTION:

- The front passenger airbag assembly is very hot when the airbag is deployed, so leave it alone for at least 30 minutes after deployment.
- Use gloves and safety glasses when handling a front passenger airbag assembly with deployed airbag.
- Always wash your hands with water after completing the operation.
- Do not apply water, etc. to a front passenger airbag assembly with deployed airbag.

- (1) When scrapping a vehicle, deploy the airbag and scrap the vehicle with the front passenger airbag assembly still installed.
- (2) When moving a vehicle for scrapping which has a front passenger airbag assembly with deployed airbag, use gloves and safety glasses.

2. DEPLOYMENT WHEN DISPOSING OF FRONT PASSENGER AIRBAG ASSEMBLY ONLY**NOTICE:**

- When disposing of the front passenger airbag assembly only, never use the customer's vehicle to deploy the airbag.
- Be sure to follow the procedure given below when deploying the airbag.

HINT:

Have a battery ready as the power source to deploy the airbag.

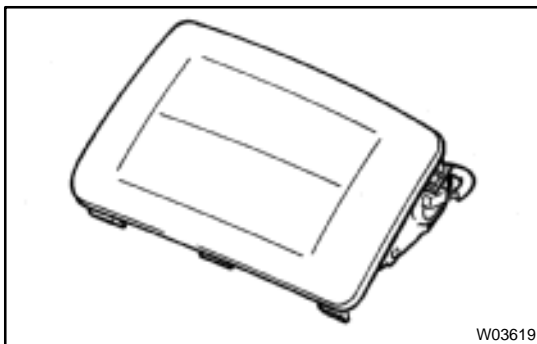

- (a) Remove the front passenger airbag assembly.
(See page [RS-28](#))

CAUTION:

- When removing the front passenger airbag assembly, work must be started 90 seconds after the ignition switch is turned to the "LOCK" position and the negative (-) terminal cable is disconnected from the battery.
- Store the front passenger airbag assembly with the airbag deployment side facing upward.

- (b) Using a service-purpose wire harness for the vehicle, tie down the front passenger airbag assembly to the tire.
Wire harness: Stripped wire harness section 1.25 mm² or more (0.0019 in.² or more)

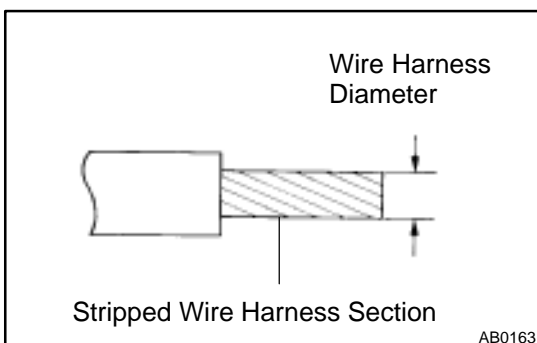

CAUTION:

If the front passenger airbag assembly is tied down with too thin wire harness, it may snap. This is highly dangerous. Always use a wire harness which is at least 1.25 mm² (0.0019 in.²).

HINT:

To calculate the square of the stripped wire harness section:

$$\text{Square} = 3.14 \times (\text{Diameter})^2 \text{ divided by } 4$$

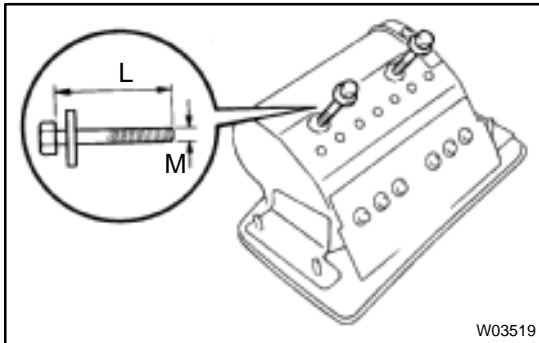

- (1) Install the 2 bolts with washers in the 2 bolt holes in the front passenger airbag assembly,

Bolt:

L: 35.0 mm (1.387 in.)

M: 6.0 mm (0.236 in.)

Pitch: 1.0 mm (0.039 in.)

NOTICE:

- Tighten the bolts by hand until the bolts become difficult to turn.
- Do not tighten the bolts too much.

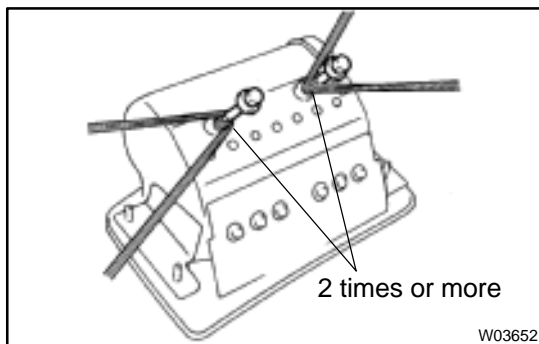

- (2) Using 3 wire harness, wind the wire harness at least 2 times each around the bolts installed on the front passenger airbag assembly.

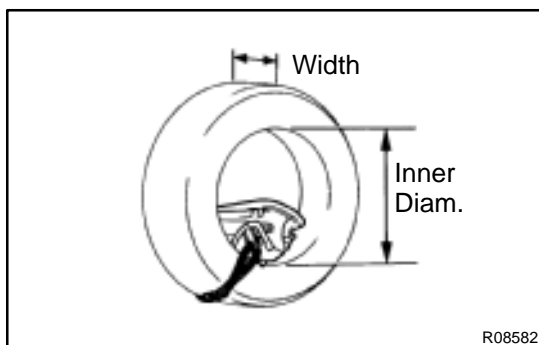

- (3) Position the front passenger airbag assembly inside the tire with the airbag deployment side facing inside.

Tire size: Must exceed the following dimensions–

Width: 185 mm (7.28 in.)

Inner diameter: 360 mm (14.17 in.)

CAUTION:

- Make sure that the wire harness is tight. It is very dangerous if looseness in the wire harness results in the front passenger airbag assembly coming free due to the shock from the airbag deploying.
- Always tie down the front passenger airbag assembly with the airbag deployment side facing inside.

NOTICE:

The tire will be marked by the airbag deployment, so use a redundant tire.

SUPPLEMENTAL RESTRAINT SYSTEM – FRONT PASSENGER AIRBAG ASSEMBLY

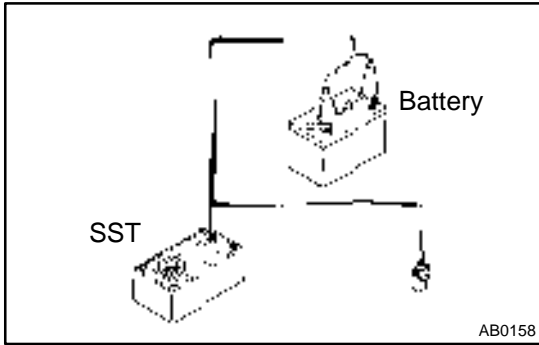

- (c) Check functioning of the SST.
SST 09082-00700

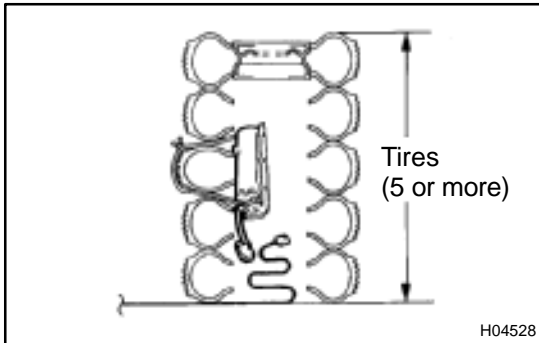

- (d) Place tires.
 - (1) Place at least 2 tires under the tire to which the front passenger airbag assembly is tied.
 - (2) Place at least 2 tires over the tire to which the front passenger airbag assembly is tied. The top tire should have the wheel installed.

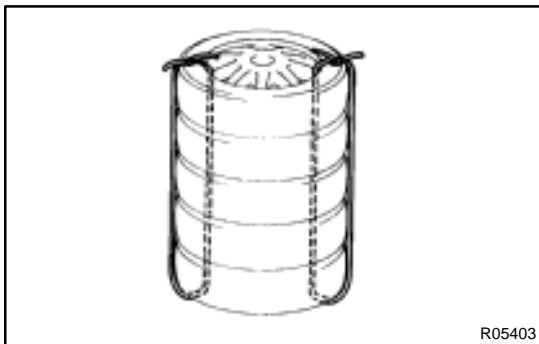

- (3) Tie the tires together with 2 wire harness.

CAUTION:

Make sure that the wire harness is tight. It is very dangerous if loose wire harness result in the tires coming free due to the shock from the airbag deploying.

HINT:

Place the SST connector and wire harness inside tires. Provide at least 1 m (3 ft) of slack for the wire harness.

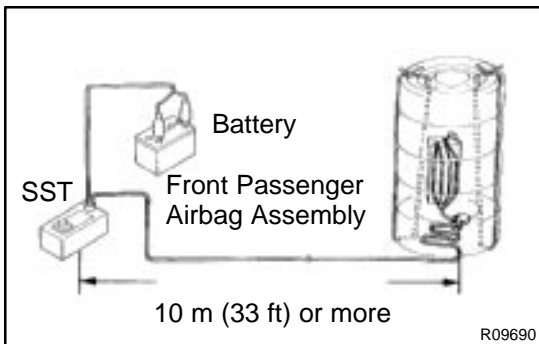

- (e) Install the SST.
Connect the connector of 2 SST to the front passenger airbag assembly connector.
SST 09082-00700, 09082-00760

NOTICE:

To avoid damaging the SST connector and wire harness, do not lock the secondary lock of the twin lock.

- (f) Deploy the airbag.
 - (1) Connect the SST red clip to the battery positive (+) terminal and the black clip to the battery negative (-) terminal.
 - (2) Check that no one is within 10 m (33 ft) area around the tire which the front passenger airbag assembly is tied to.
 - (3) Press the SST activation switch and deploy the airbag.

HINT:

The airbag deploys simultaneously as the LED of the SST activation switch lights up.



(g) Dispose of the front passenger airbag assembly.

CAUTION:

- **The front passenger airbag assembly is very hot when the airbag is deployed, so leave it alone for at least 30 minutes after deployment.**
- **Use gloves and safety glasses when handling a front passenger airbag assembly with deployed airbag.**
- **Always wash your hands with water after completing the operation.**
- **Do not apply water, etc. to a front passenger airbag assembly with deployed airbag.**
 - (1) Remove the front passenger airbag assembly from the tire.
 - (2) Place the front passenger airbag assembly in a vinyl bag, tie the end tightly and dispose of it in the same way as other general parts.

REPLACEMENT

REPLACEMENT REQUIREMENTS

In the following cases, replace the front passenger airbag assembly, instrument panel or instrument panel reinforcement.

Case	Replacing part
If the airbag has been deployed.	Front passenger airbag assembly
If the front passenger airbag assembly has been found to be faulty in troubleshooting.	Front passenger airbag assembly
If the front passenger airbag assembly has been found to be faulty during checking items. (See page RS-29)	Front passenger airbag assembly
If the instrument panel has been found to be faulty during checking items. (See page RS-29)	Instrument panel
If the instrument panel reinforcement has been found to be faulty during checking items. (See page RS-29)	Instrument panel reinforcement
If the front passenger airbag assembly has been dropped.	Front passenger airbag assembly

CAUTION:

For replacement of the front passenger airbag assembly, see page RS-28 and RS-38. Be sure to follow the correct procedure.

INSTALLATION

NOTICE:

Never use airbag parts from another vehicle. When replacing parts, replace them with new parts.

HINT:

For step 2 to 4, refer to page [BO-81](#).



1. **INSTALL FRONT PASSENGER AIRBAG ASSEMBLY**
 - (a) Install the front passenger airbag assembly with the 2 bolts.
Torque: 20 N·m (205 kgf-cm, 15 ft-lbf)
 - (b) Install the 4 nuts.

CAUTION:

- Make sure that no foreign objects are trapped between the airbag bag and the module.
- Do not damage the strap when installing the module.

NOTICE:

If the front passenger airbag assembly has been dropped, or there are cracks, dents or other defects in the case or connector, replace the front passenger airbag assembly with a new one.

2. **INSTALL GLOVE COMPARTMENT BOX**
3. **INSTALL COWL SIDE TRIM**
4. **INSTALL FRONT DOOR SCUFF PLATE**

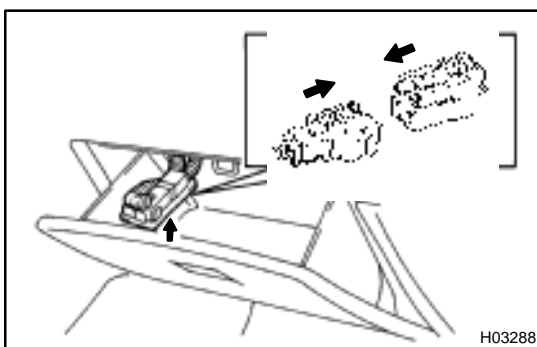

5. **CONNECT AIRBAG CONNECTOR**
 - (a) Connect the airbag connector.
 - (b) Put the connector on the glove compartment door finish plate.
 - (c) Install the glove compartment door finish plate to the glove compartment box.

SIDE AIRBAG ASSEMBLY (TMC Made) COMPONENTS

RS05G-02

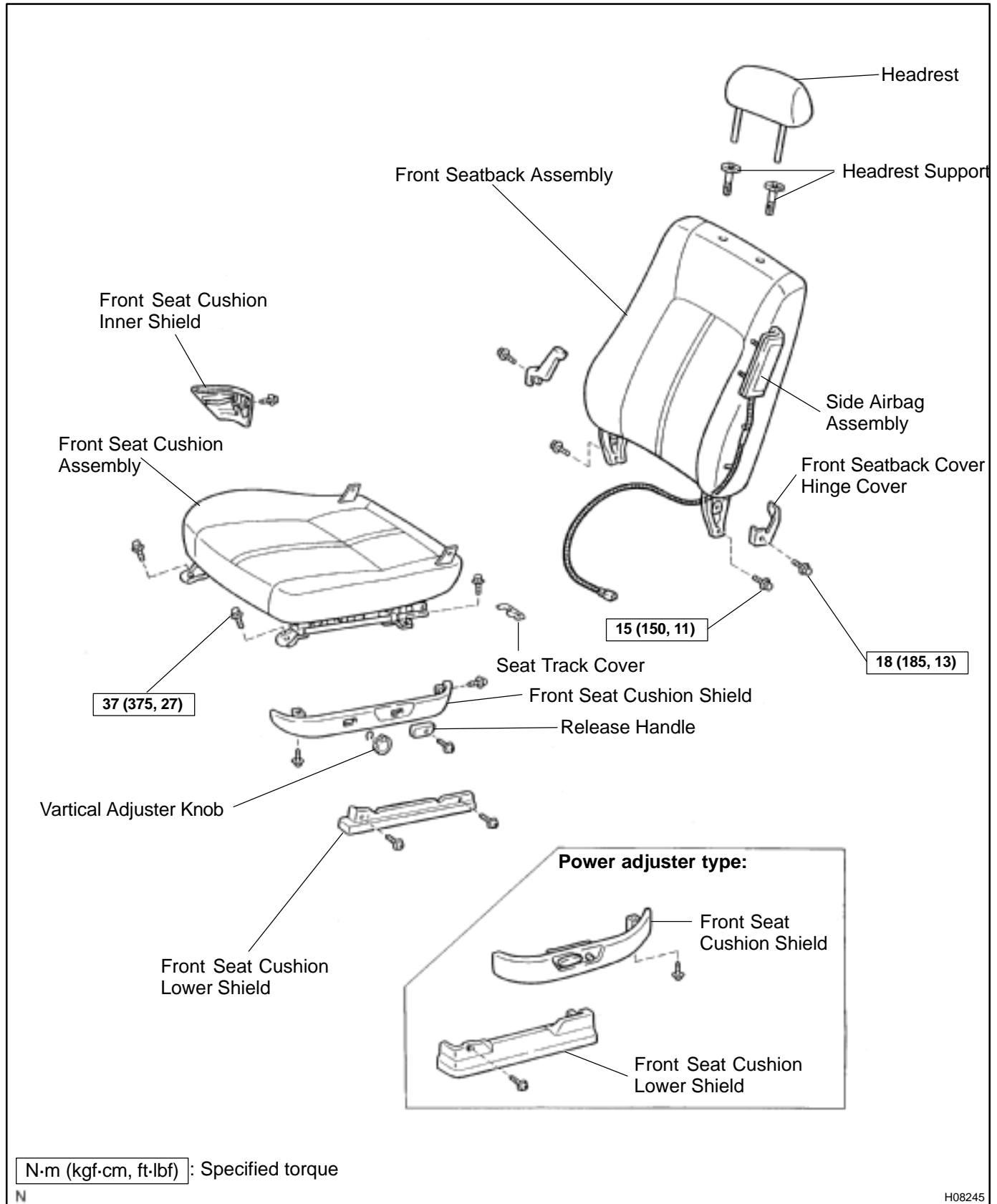

REMOVAL

NOTICE:

- If the wiring connector of the SRS is disconnected and the ignition switch is in ON or ACC position, DTCs will be recorded.
- Never use the airbag parts from another vehicle. When replacing parts, replace them with new parts.



1. REMOVE FRONT SEAT

- (a) Remove the 2 seat track covers and 4 bolts.
- (b) Power adjuster type:
Disconnect the power seat and side airbag connectors.
- (c) Manual adjuster type:
Disconnect the side airbag connector.

NOTICE:

When handling the airbag connector, take care not to damage the airbag wire harness.

- (d) Remove the front seat.

NOTICE:

Be careful not to damage the body.

2. REMOVE FRONT SEAT CUSHION LOWER SHIELD

3. Manual adjuster type:

REMOVE RELEASE HANDLE

4. Manual adjuster type:

REMOVE VERTICAL ADJUSTER KNOB

5. Power adjuster type:

DISCONNECT CONNECTOR

Disconnect the connector from the power seat switch.

6. REMOVE FRONT SEAT CUSHION SHIELD

7. REMOVE FRONT SEAT CUSHION INNER SHIELD

8. REMOVE HEADREST

9. REMOVE HEADREST SUPPORT

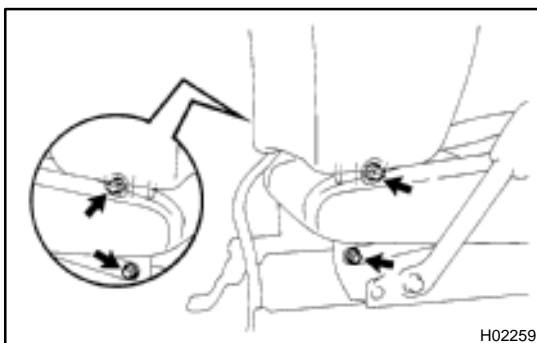

10. REMOVE SEATBACK ASSEMBLY

- (a) Remove the 4 bolts.
- (b) Remove the hog rings.
- (c) Remove the seatback assembly.

INSPECTION

1. VEHICLE NOT INVOLVED IN COLLISION

- (a) Do a diagnostic system check. (See page [DI-626](#))
- (b) Do a visual check which includes the following items with the seatback assembly installed in the vehicle.

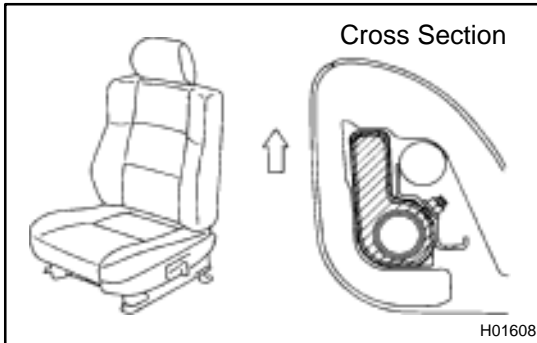

Check that there are no cuts or frayed seams and outside of seatback cover.

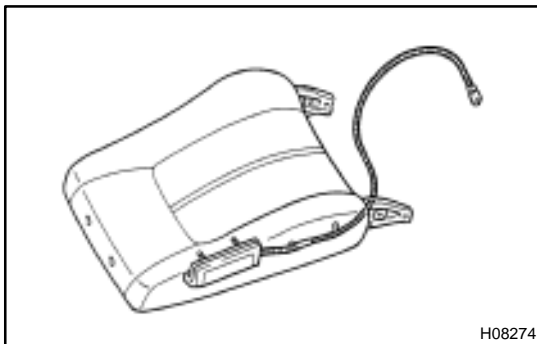

2. VEHICLE INVOLVED IN COLLISION AND AIRBAG IS NOT DEPLOYED

- (a) Do a diagnostic system check. (See page [DI-626](#))
- (b) Do a visual check which includes the following items with the seatback assembly removed from the vehicle.
 - Check cuts and cracks of the side airbag assembly.
 - Check cuts and cracks in wire harnesses, and chipping in connectors.

CAUTION:

For removal and installation of the seatback assembly, see page [RS-40](#) and [RS-49](#). Be sure to follow the correct procedure.

3. VEHICLE INVOLVED IN COLLISION AND AIRBAG IS DEPLOYED

- (a) Do a diagnostic system check.
(See page [DI-626](#))
- (b) Do a visual check which includes the following items with the seatback assembly removed from the vehicle.
 - Check the seatback installation part of the seat adjuster.
 - Check the damage to the connector and wire harness.

HINT:

If the seat adjuster is deformed, never repair it. Always replace it with a new one.

DISPOSAL

HINT:

When scrapping vehicles equipped with an SRS or disposing of the side airbag assembly always first deploy the airbag in accordance with the procedure described below. If any abnormality occurs with the airbag deployment, contact the SERVICE DEPT. of TOYOTA MOTOR SALES, U.S.A., INC.

When disposing of a side airbag assembly with an airbag deployed in a collision, follow the same procedure given in step 1-(e) in "DISPOSAL".

CAUTION:

- Never dispose of a side airbag assembly which has an undeployed airbag.
- The airbag produces a sizeable exploding sound when it deploys, so perform the operation out of doors and where it will not create a nuisance to nearby residents.



- When deploying the airbag, always use the specified SST (SRS Airbag Deployment Tool), perform the operation in a place away from electrical noise.
SST 09082-00700
- When deploying an airbag, perform the operation at least 10 m (33 ft) away from the airbag assembly.
- The side airbag assembly is very hot when the airbag is deployed, so leave it alone for at least 30 minutes after deployment.
- Use gloves and safety glasses when handling side airbag assembly with the deployed airbag.
- Always wash your hands with water after completing the operation.
- Do not apply water, etc. to a side airbag assembly with the deployed airbag.

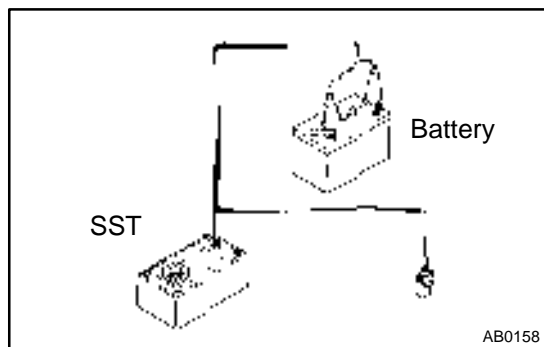

1. AIRBAG DEPLOYMENT WHEN SCRAPPING VEHICLE

HINT:

Have a battery ready as the power source to deploy the airbag.

- (a) Check functioning of the SST. (See page RS-18)
SST 09082-00700



- (b) Disconnect the side airbag connector.

NOTICE:

When handling the airbag connector, take care not to damage the airbag wire harness.

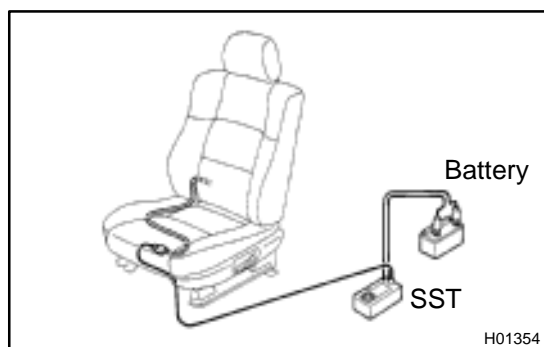

- (c) Install the SST.

- (1) Connect the connector of 2 SST to the airbag connector.

SST 09082-00700, 09082-00750

NOTICE:

To avoid damaging the SST connector and wire harness, do not lock the secondary lock of the twin lock.

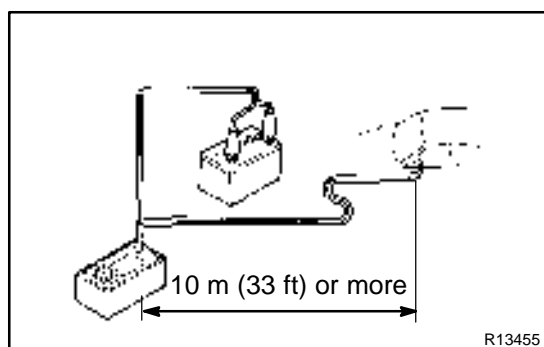

- (2) Move the SST at least 10 m (33 ft) away from the front of the vehicle.

- (3) Close all the doors and windows of the vehicle.

NOTICE:

Take care not to damage the SST wire harness.

- (4) Connect the SST red clip to the battery positive (+) terminal and the black clip to the battery negative (-) terminal.



- (d) Deploy the airbag.

- (1) Check that no one is inside the vehicle or within 10 m (33 ft) area around the vehicle.

- (2) Press the SST activation switch and deploy the airbag.

HINT:

The airbag deploys simultaneously as the LED of SST activation switch lights up.

- (e) Dispose of side airbag assembly.

CAUTION:

- The side airbag assembly is very hot when the airbag is deployed, so leave it alone for at least 30 minutes after deployment.
- Use gloves and safety glasses when handling a side airbag assembly with the deployed airbag.
- Do not apply water, etc. to a side airbag assembly with the deployed airbag.
- Always wash your hands with water after completing the operation.

When scrapping a vehicle, deploy the airbag and scrap the vehicle with the side airbag assembly still installed.

2. DEPLOYMENT WHEN DISPOSING OF SIDE AIRBAG ASSEMBLY

NOTICE:

- When disposing of the side airbag assembly only, never use the customer's vehicle to deploy the airbag.
- Be sure to follow the procedure given below when deploying the airbag.

HINT:

Have a battery ready as the power source to deploy the airbag.

- (a) Remove the seatback assembly.
- (b) Remove the side airbag assembly from the seatback assembly.

CAUTION:

Store the side airbag assembly with the airbag deployment side facing upward.

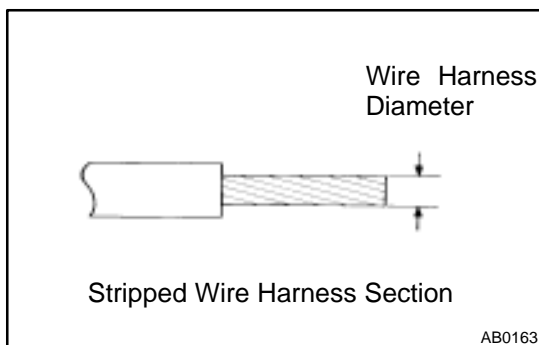

- (c) Using a service-purpose wire harness tie down the side airbag assembly.

**Wire harness: Stripped wire harness section
1.25 mm² or more (0.0019 in² or more)**

CAUTION:

If a wire harness which is too thin or some other thing is used to tie down the side airbag assembly, it may be snapped by the shock when the airbag is deployed. This is highly dangerous. Always use a wire harness for vehicle use which is at least 1.25 mm² (0.0019 in²).

HINT:

To calculate the square of the stripped wire harness section:

$$\text{Square} = 3.14 \times (\text{Diameter})^2 \text{ divided by } 4$$

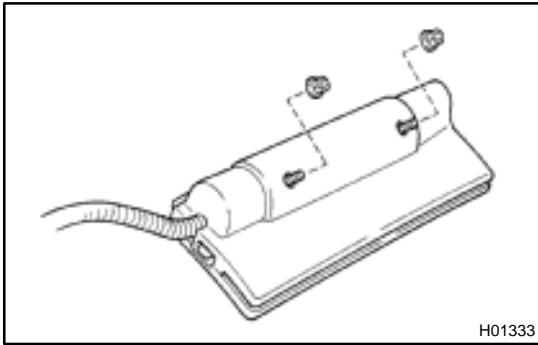

(1) Install the 2 nuts to the side airbag assembly.

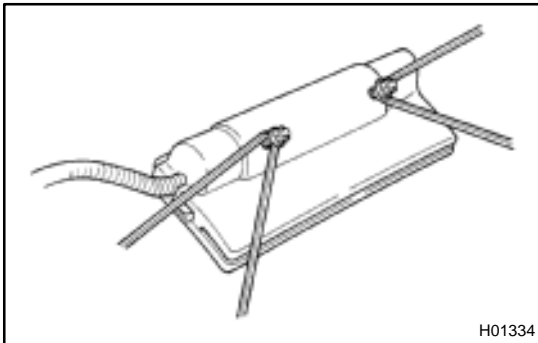

(2) Wind the wire harness around the stud bolts of the side airbag assembly as shown in the illustration.

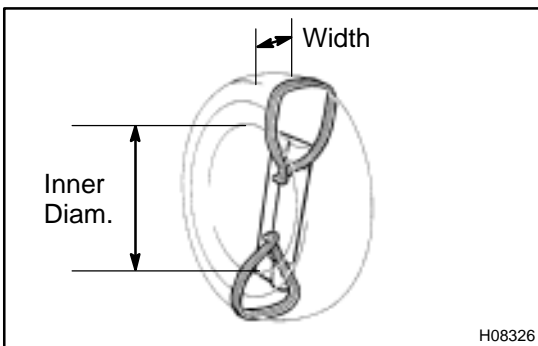

(3) Position the side airbag assembly inside the tire with the airbag deployment direction facing inside.

Tire size : Must exceed the following dimensions:–

Width 185 mm (7.28 in.)

Inner diameter 360 mm (14.17 in.)

CAUTION:

- Make sure the wire harness is tight. It is very dangerous when a loose wire harness results in the side airbag assembly coming free due to the shock from the airbag deploying.
- Always tie down the side airbag assembly with the airbag door facing inside.

NOTICE:

The tire will be marked by the airbag deployment, so when disposing of the airbag use a redundant tire.

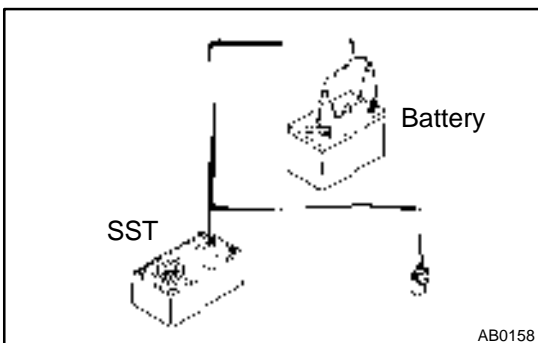

(d) Check functioning of the SST. (See page [RS-18](#))

SST 09082-00700

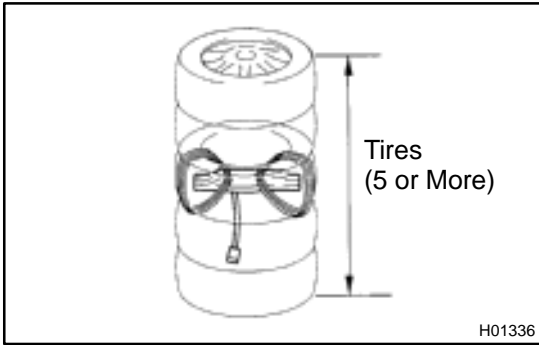

H01336

- (e) Place the tires.
 - (1) Place at least 2 tires under the tire to which the side airbag assembly is tied.
 - (2) Place at least 2 tires over the tire to which the side airbag assembly is tied. The top tire should have the wheel installed.

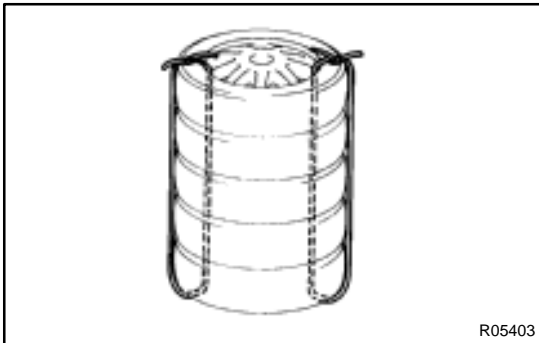

R05403

- (3) Tie the tires together with the 2 wire harnesses.

CAUTION:

Make sure that the wire harnesses are tight. It is very dangerous when loose wire harnesses result in the tires coming free due to the shock from the airbag deploying.

HINT:

Place the SST connector and wire harness inside tires. Secure at least 1 m (3 ft) of slack for the wire harness.

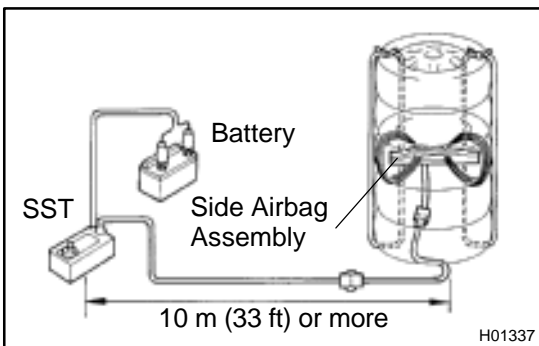

H01337

- (f) Install the SST.
 - Connect the connector of 2 SST to the side airbag assembly connector.
 - SST 09082-00700, 09082-00750
- (g) Deploy the airbag.
 - (1) Connect the SST red clip to the battery positive (+) terminal and the black clip to the battery negative (-) terminal.
 - (2) Check that no one is within 10 m (33 ft) area around the tire which the side airbag assembly is tied to.
 - (3) Press the SST activation switch and deploy the airbag.

HINT:

The airbag deploys simultaneously as the LED of the SST activation switch lights up.



H00544

- (h) Dispose of the side airbag assembly.

CAUTION:

- The side airbag assembly is very hot when the airbag is deployed, so leave it alone for at least 30 minutes after deployment.
- Use gloves and safety glasses when handling a side airbag assembly with the deployed airbag.
- Do not apply water etc. to a side airbag assembly with the deployed airbag.

- **Always wash your hands with water after completing the operation.**
 - (1) Remove the side airbag assembly from the tire.
 - (2) Place the side airbag assembly in a vinyl bag, tie the end tightly and dispose of it in the same way as other general parts disposal.

REPLACEMENT

REPLACEMENT REQUIREMENTS

In the following cases, replace the seatback assembly or seatback cover.

Case	Replacing part
If the side airbag has been deployed.	Seatback assembly
If the side airbag assembly has been found to be faulty in troubleshooting.	Seatback assembly
If the side airbag assembly has cuts during checking items. (See page RS-41)	Seatback assembly
If the seatback cover has cuts and frayed seams during checking items. (See page RS-41)	Seatback cover
If the side airbag assembly has been found to be faulty during checking items. (See page RS-41)	Seatback assembly
If the seatback cover has been found to be faulty during checking items. (See page RS-41)	Seatback cover
If the seatback assembly has been dropped.	Seatback assembly

CAUTION:

For removal and installation of the seatback assembly, see page [RS-40](#) and [RS-49](#). Be sure to follow the correct procedure.

INSTALLATION

NOTICE:

Never use airbag parts from another vehicle. When replacing parts, replace them with new parts.

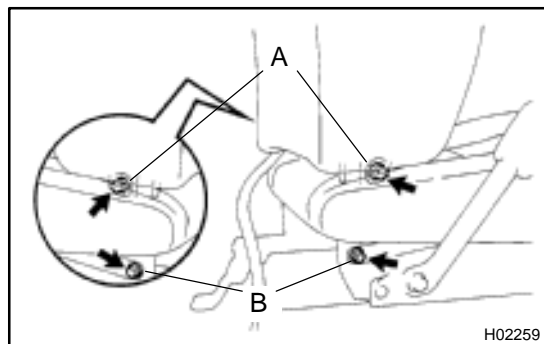

1. INSTALL SEATBACK ASSEMBLY

- (a) Install the seatback assembly.
- (b) Install new hog rings.

HINT:

Install the hog rings to prevent wrinkles as little as possible.

- (c) Install the 4 bolts.

Torque:

Bolt A: 18 N·m (185 kgf·cm, 13 ft·lbf)

Bolt B: 15 N·m (150 kgf·cm, 11 ft·lbf)

2. INSTALL FRONT SEAT CUSHION INNER SHIELD

3. INSTALL FRONT SEAT CUSHION SHIELD

4. Manual adjuster type:

INSTALL VERTICAL ADJUSTER KNOB

5. Manual adjuster type:

INSTALL RELEASE HANDLE

6. Power adjuster type:

CONNECT CONNECTOR

Connect the connector to the power seat switch.

7. INSTALL FRONT SEAT CUSHION LOWER SHIELD

8. INSTALL HEADREST SUPPORT

9. INSTALL HEADREST

10. INSTALL FRONT SEAT

- (a) Slide the front seat to the most front position.

NOTICE:

Make sure that seat adjuster locks.

- (b) Without holding the seat track handle, mount the seat to the vehicle.

HINT:

If holding the seat track handle, the adjusted most front position will slip off.

- (c) Power adjuster type:

Connect the side airbag connector and power seat connector.

- (d) Manual adjuster type:

Connect the side airbag connector.

- (e) Tighten the bolts on the rear side temporarily, starting from the bolt on the inner side tighten them completely.

Torque: 37 N·m (375 kgf·cm, 27 ft·lbf)

- (f) Slide the seat to the rearmost position to install the bolts on the front side.

Torque: 37 N·m (375 kgf·cm, 27 ft·lbf)

SIDE AIRBAG ASSEMBLY (TMMK Made) COMPONENTS

RS05M-03

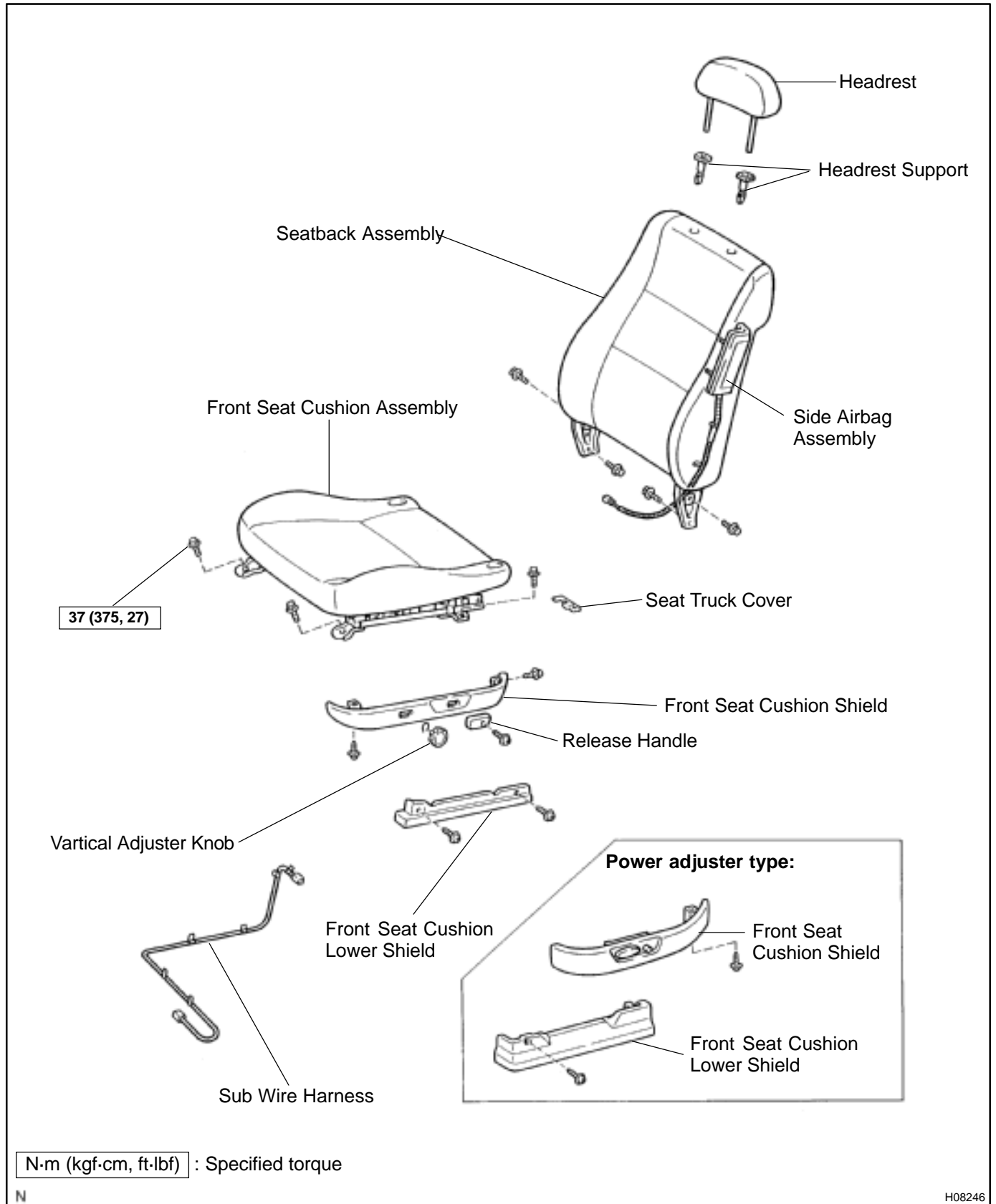

H08246

REMOVAL

NOTICE:

- If the wiring connector of the SRS is disconnected and the ignition switch is at ON or ACC position, DTCs will be recorded.
- Never use the airbag parts from another vehicle. When replacing parts, replace them with new parts.



1. REMOVE FRONT SEAT

- (a) Remove the 2 seat track covers and 4 bolts.
- (b) Power adjuster type:
Disconnect the power seat and side airbag connectors.
- (c) Manual adjuster type:
Disconnect the side airbag connector.

NOTICE:

When handling the airbag connector, take care not to damage the airbag wire harness.

- (d) Remove the front seat.

NOTICE:

Be careful not to damage the body.

2. REMOVE FRONT SEAT CUSHION LOWER SHIELD

3. Manual adjuster type:

REMOVE RELEASE HANDLE

4. Manual adjuster type:

REMOVE VERTICAL ADJUSTER KNOB

5. Power adjuster type:

DISCONNECT CONNECTOR

Disconnect the connector from the power seat switch.

6. REMOVE FRONT SEAT CUSHION SHIELD

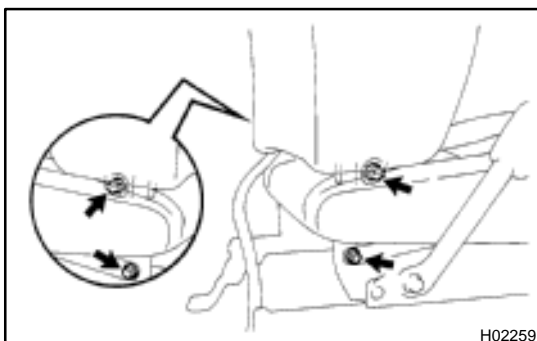

7. REMOVE SEATBACK ASSEMBLY

- (a) Remove the 4 bolts.
- (b) Remove the hog rings.
- (c) Disconnect the side airbag connector of the side airbag assembly side.

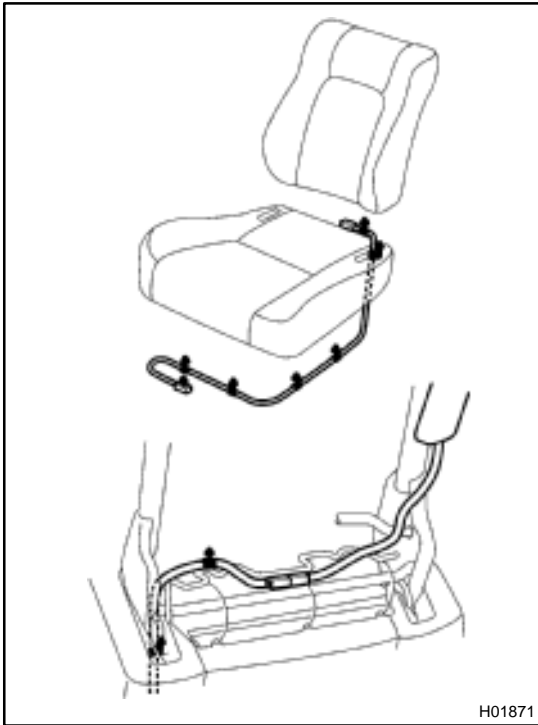

H01871

- (d) Remove the side airbag sub wire harness after removing clips.
- (e) Remove the seatback assembly.

INSPECTION

1. VEHICLES NOT INVOLVED IN COLLISION

- (a) Do a diagnostic system check. (See page [DI-626](#))
- (b) Do a visual check which includes the following items with the seatback assembly installed in the vehicle.

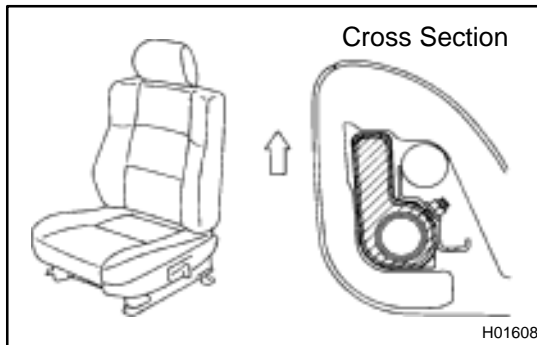

Check that there are no cuts or frayed in seams and outside of seatback cover.

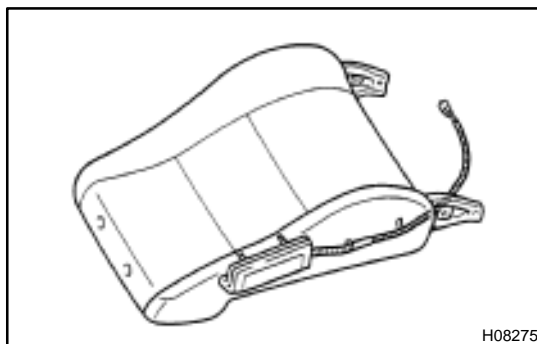

2. VEHICLE INVOLVED IN A COLLISION AND AIRBAG IS NOT DEPLOYED

- (a) Do a diagnostic system check. (See page [DI-626](#))
- (b) Do a visual check which includes the following items with the seatback assembly removed from the vehicle.
 - Check cuts and cracks of the side airbag assembly.
 - Check cuts and cracks in wire harnesses, and chipping in connectors.

CAUTION:

For removal and installation of the seatback assembly, see page [RS-52](#) and [RS-57](#). Be sure to follow the correct procedure.

3. VEHICLE INVOLVED IN A COLLISION AND AIRBAG IS DEPLOYED

- (a) Do a diagnostic system check. (See page [DI-626](#))
- (b) Do a visual check which includes the following items with the seatback assembly removed from the vehicle.
 - Check the seatback installation part of the seat adjuster.
 - Check the damage to the connector and wire harness.

HINT:

If the seat adjuster is deformed, never repair it. Always replace it with a new one.

DISPOSAL

(See page [RS-42](#))

REPLACEMENT

REPLACEMENT REQUIREMENTS

In the following cases, replace the seatback assembly or seat cover.

Case	Replacing part
If the side airbag has been deployed.	Seatback assembly
If the side airbag assembly has been found to be faulty in troubleshooting.	Seatback assembly
If the side airbag assembly has cuts during checking items. (See page RS-54)	Seatback assembly
If the seatback cover has cuts and frayed seams during checking items. (See page RS-54)	Seatback cover
If the side airbag assembly has been found to be faulty during checking items. (See page RS-54)	Seatback assembly
If the seatback cover has been found to be faulty during checking items. (See page RS-54)	Seatback cover
If the seatback assembly has been dropped.	Seatback assembly

CAUTION:

For removal and installation of the seatback assembly, see page [RS-52](#) and [RS-57](#). Be sure to follow the correct procedure.

INSTALLATION

NOTICE:

Never use airbag parts from another vehicle. When replacing parts, replace them with new parts.

1. INSTALL SEATBACK ASSEMBLY

- (a) Install the seatback assembly.

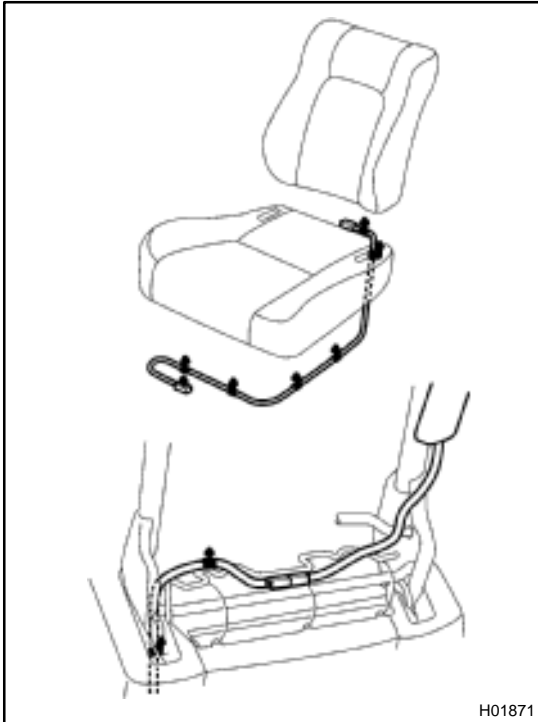

- (b) Securely fix the side airbag sub wire harness to the seat cushion with clips.

- (c) Connect the side airbag connector of the side airbag assembly side.

- (d) Install new hog rings.

HINT:

Install the hog rings to prevent wrinkles as little as possible.

- (e) Install the 4 bolts.

2. INSTALL FRONT SEAT CUSHION SHIELD

3. Manual adjuster type:

INSTALL VERTICAL ADJUSTER KNOB

4. Manual adjuster type:

INSTALL RELEASE HANDLE

5. Power adjuster type:

CONNECT CONNECTOR

Connect the connector to the power seat switch.

6. INSTALL FRONT SEAT CUSHION LOWER SHIELD

7. INSTALL HEADREST SUPPORT

8. INSTALL HEADREST

9. INSTALL FRONT SEAT

- (a) Slide the front seat to the most front position.

NOTICE:

Make sure that seat adjuster locks.

- (b) Without holding the seat track handle, mount the seat to the vehicle.

HINT:

If holding the seat track handle, the adjusted most front position will slip off.

- (c) Tighten the bolts on the rear side temporarily, starting from the bolt on the inner side tighten them completely.

Torque: 37 N·m (375 kgf·cm, 27 ft·lbf)

- (d) Slide the seat to the rearmost position to install the bolts on the front side.

Torque: 37 N·m (375 kgf·cm, 27 ft·lbf)

- (e) Power adjuster type:

Connect the side airbag connector and power seat connector.

- (f) Manual adjuster type:

Connect the side airbag connector.

AIRBAG SENSOR ASSEMBLY COMPONENTS

RS01G-11

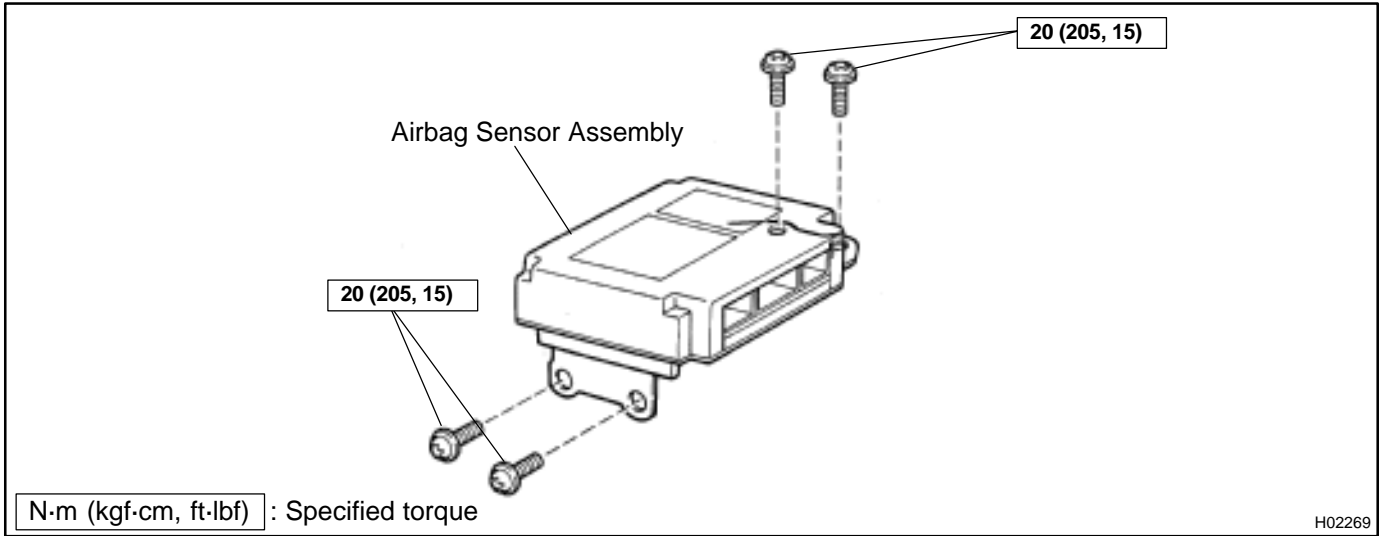

REMOVAL

NOTICE:

Do not open the cover or the case of the ECU and various electrical devices unless absolutely necessary.

(If the IC terminals are touched, the IC may be destroyed by static electricity.)

LH side:

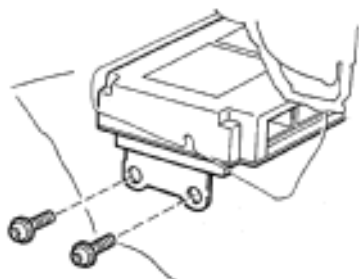

RH side:

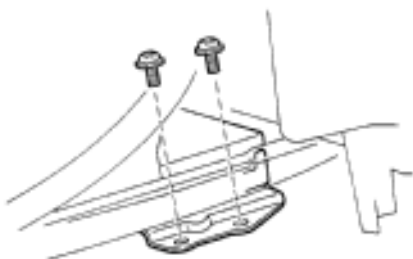

H02268

H08322

REMOVE AIRBAG SENSOR ASSEMBLY

- (a) Disconnect the airbag sensor connectors.

NOTICE:

Disconnect the connectors with the sensor assembly installed.

- (b) Using a torx wrench, remove the 4 screws and airbag sensor assembly.

Torx wrench: T40 (Part No.09042-00020 or locally manufactured tool)

INSPECTION

1. VEHICLE NOT INVOLVED IN COLLISION

Do a diagnostic system check. (See page [DI-626](#))

2. VEHICLE INVOLVED IN COLLISION AND AIRBAG IS NOT DEPLOYED

Do a diagnostic system check. (See page [DI-626](#))

3. VEHICLE INVOLVED IN COLLISION AND AIRBAG IS DEPLOYED

Replace the airbag sensor assembly. (See page [RS-59](#))

REPLACEMENT

REPLACEMENT REQUIREMENTS

In the following cases, replace the airbag sensor assembly.

- If the SRS has been deployed in a collision.
- If the airbag sensor assembly has been found to be faulty in troubleshooting.
- If the airbag sensor assembly has been dropped.

CAUTION:

For removal and installation of the airbag sensor assembly, see page [RS-59](#) and [RS-62](#). Be sure to follow the correct procedure.

INSTALLATION

NOTICE:

- Never use SRS parts from another vehicle. When replacing parts, replace them with new parts.
- Never reuse the airbag sensor assembly involved in a collision when the airbag has deployed.
- Never repair a sensor in order to reuse it.

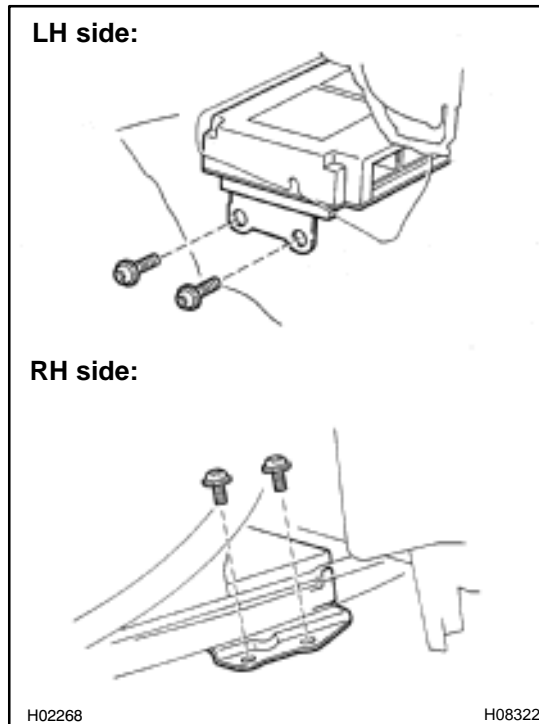

INSTALL AIRBAG SENSOR ASSEMBLY

- (a) Using a torx wrench, install the airbag sensor assembly with 4 screws.

Torx wrench: T40 (Part No.09042-00020 or locally manufactured tool)

Torque: 20 N·m (205 kgf·cm, 15 ft·lbf)

- (b) Connect the airbag sensor connectors.

NOTICE:

- Connection of the connector is done after the sensor assembly has been installed.
- Make sure the sensor assembly is installed with the specified torque.
- If the sensor assembly has been dropped, or there are cracks, dents or other defects in the case, bracket or connector, replace the sensor assembly with a new one.
- When installing the sensor assembly, take care that the SRS wiring does not interfere with other parts and is not pinched between other parts.
- After installing, shake the sensor assembly to check that there is no looseness.

FRONT AIRBAG SENSOR COMPONENTS

RS01L-14

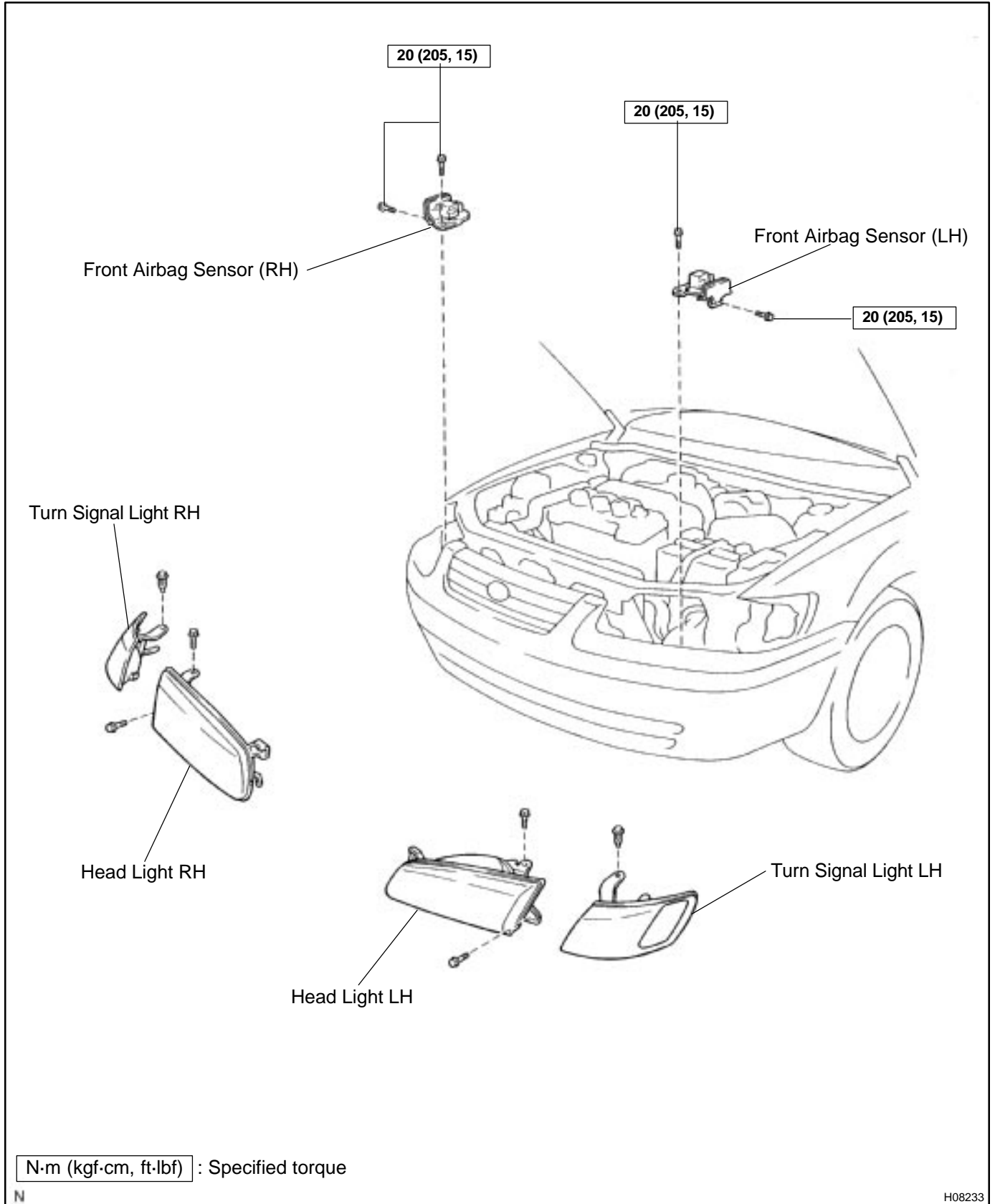

REMOVAL

NOTICE:

- If the wiring connector of the SRS is disconnected with the ignition switch at ON or ACC position, DTCs will be recorded.
- Never use SRS parts from another vehicle. When replacing parts, replace them with new parts.
- Never reuse the sensor involved in a collision when the SRS has deployed.
- Never repair a sensor in order to reuse it.

1. REMOVE HEAD LIGHT LH AND RH

- (a) Remove the 2 clips and turn signal lights.
- (b) Remove the 4 bolts and head lights.

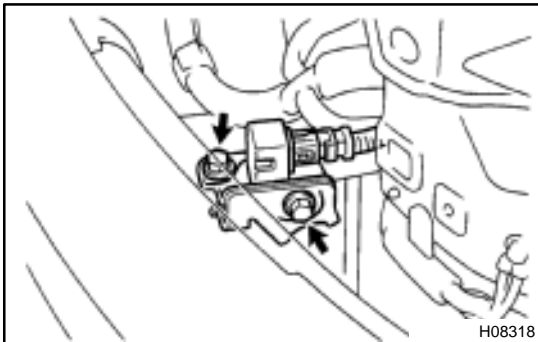

2. LH: REMOVE FRONT AIRBAG SENSOR

- (a) Disconnect the connector.

NOTICE:

Disconnect the connector with sensor assembly installed.

- (b) Remove the 2 bolts and front airbag sensor LH.

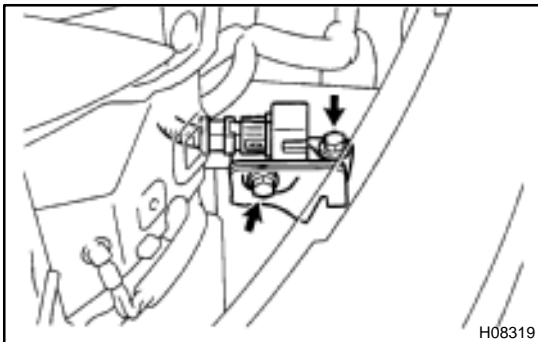

3. RH: REMOVE FRONT AIRBAG SENSOR

- (a) Disconnect the connector.

NOTICE:

Disconnect the connector with sensor assembly installed.

- (b) Remove the 2 bolts and front airbag sensor RH.

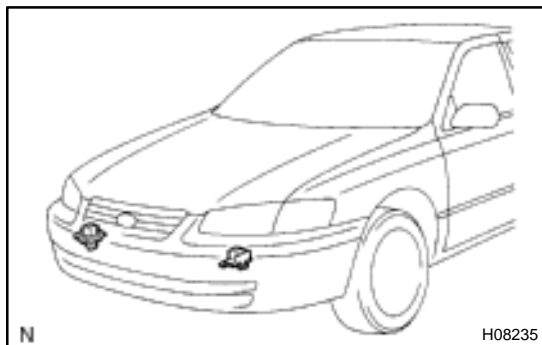

INSPECTION

1. VEHICLE NOT INVOLVED IN COLLISION

Do a diagnostic system check.

(See page [DI-626](#))

2. VEHICLE INVOLVED IN COLLISION

(a) Do a diagnostic system check.

(See page [DI-626](#))

(b) If the front fender of the car or its periphery is damaged, do a visual check for damage to the front airbag sensor, which includes the following items even if the airbag was not deployed:

- Bracket deformation
- Paint peeling off the bracket
- Cracks, dents or chips in the case
- Cracks, dents, chipping and scratches in the connector
- Peeling off of the label or damage to the serial number

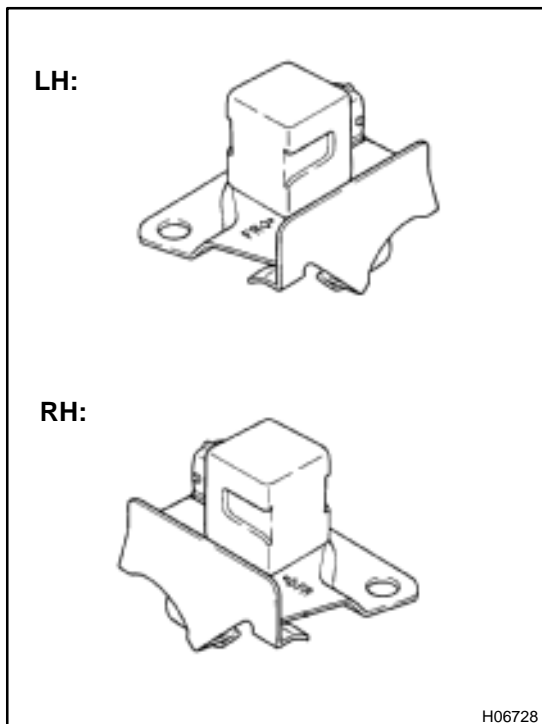

REPLACEMENT

REPLACEMENT REQUIREMENTS

In the following cases, replace the front airbag sensor.

- If the SRS has been deployed in a collision. (Replace both the left and right airbag sensors.)
- If the front airbag sensor has been found to be faulty in troubleshooting.
- If the front airbag sensor has been found to be faulty during checking items.
(See page [RS-65](#))
- If the front airbag sensor has been dropped.

CAUTION:

For removal and installation of the front airbag sensor, see page [RS-64](#) and [RS-67](#). Be sure to follow the correct procedure.

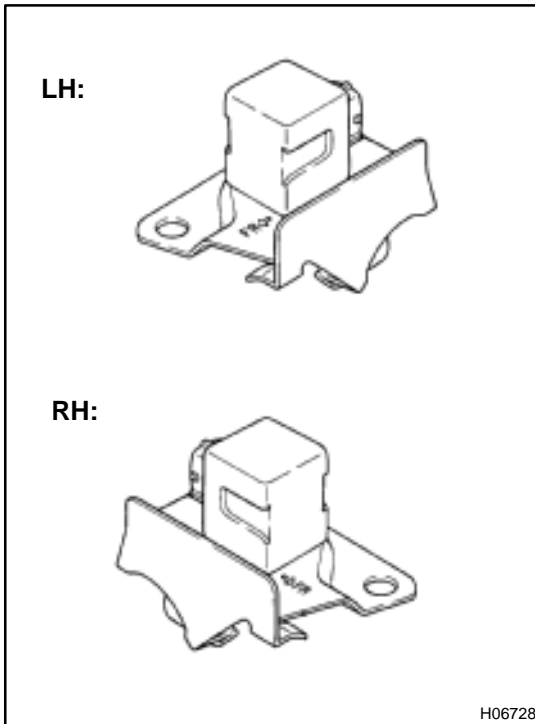

INSTALLATION

1. INSTALL FRONT AIRBAG SENSOR LH AND RH

- (a) Install the front airbag sensor with the arrow on the sensor facing toward the front of the vehicle.

Torque: 20 N·m (205 kgf-cm, 15 ft-lbf)

NOTICE:

- Connection of the connector is done after the sensor assembly has been installed.
- Make sure the sensor is installed with the specified torque.
- If the sensor has been dropped, or there are cracks, dents or other defects in the case, brackets or connector, replace the removed sensor with a new one.
- The front sensor is equipped with an electrical connection check mechanism. Be sure to lock this mechanism securely when connecting the connector. If the connector is not securely locked, a malfunction code will be detected by the diagnostic system.

- (b) Connect the front airbag sensor connector.

2. INSTALL HEAD LIGHT LH AND RH

(See page [BE-28](#))

3. INSTALL TURN SIGNAL LIGHT LH AND RH

SIDE AIRBAG SENSOR ASSEMBLY COMPONENTS

RS01Q-06

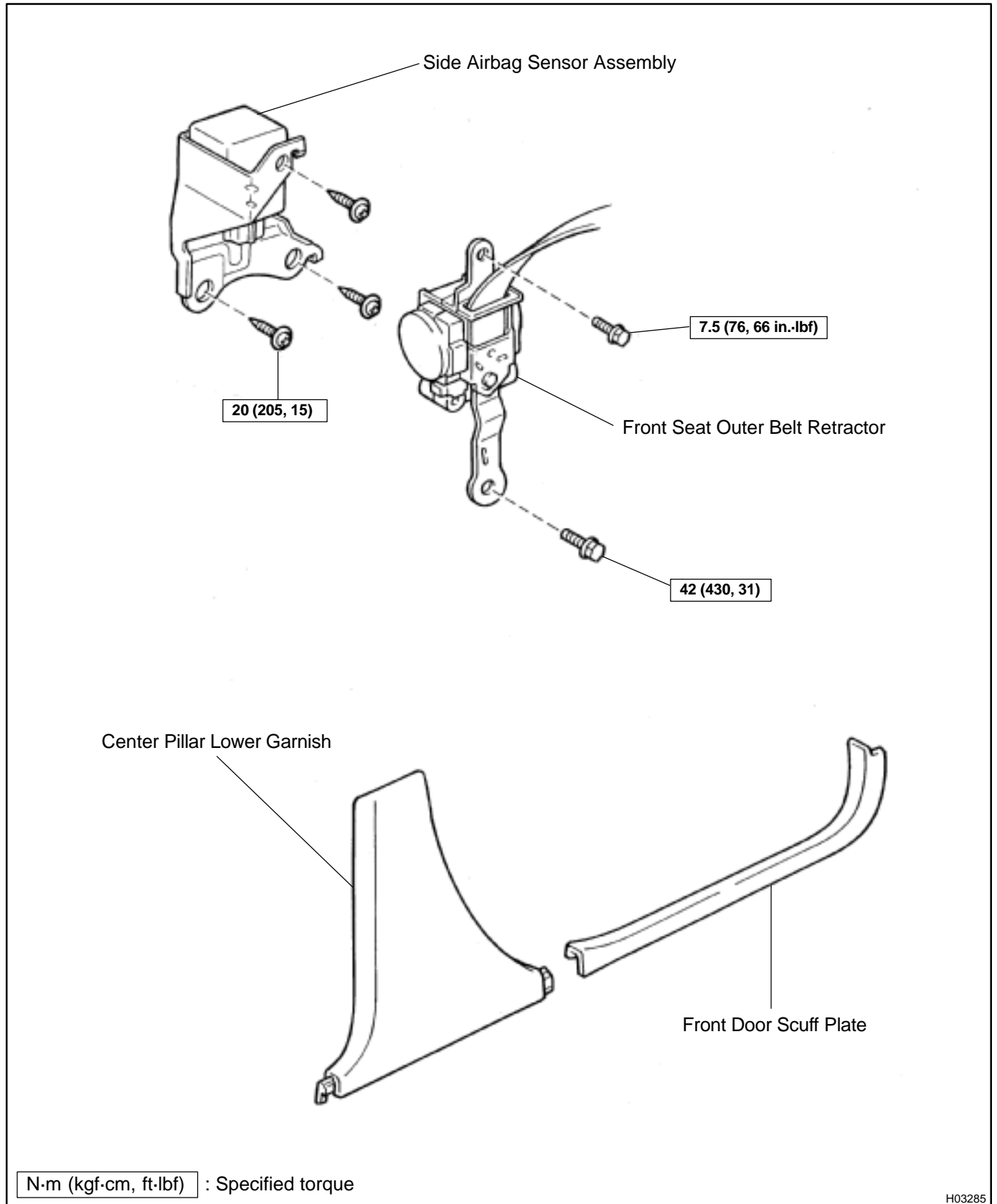

H03285

REMOVAL

NOTICE:

Do not open the cover or the case of the ECU and various electrical devices unless absolutely necessary.

(If the IC terminals are touched, the IC may be destroyed by static electricity.)

1. REMOVE FRONT DOOR SCUFF PLATE
2. REMOVE CENTER PILLAR LOWER GARNISH

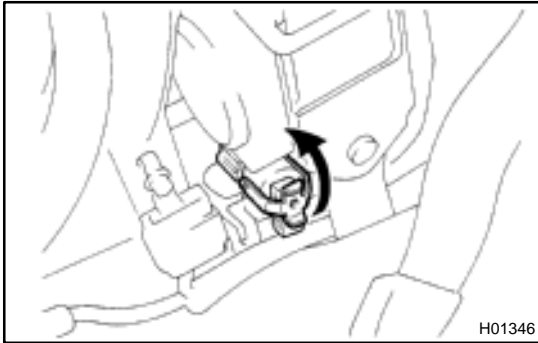

3. REMOVE FRONT SEAT OUTER BELT RETRACTOR
(See page [BO-126](#))

- (a) Disconnect the pretensioner connector.
- (b) Remove the 2 bolts and retractor.

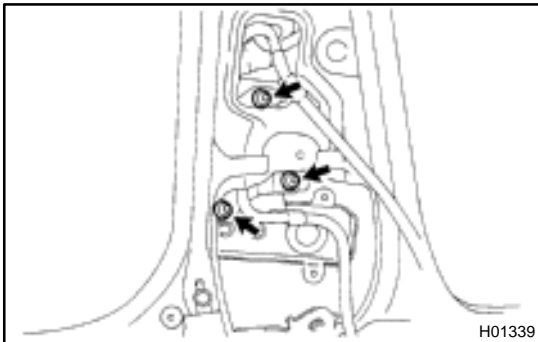

4. REMOVE SIDE AIRBAG SENSOR ASSEMBLY

- (a) Disconnect the side airbag sensor assembly connector.

NOTICE:

Disconnect the connector with the sensor assembly installed.

- (b) Using a torx wrench, remove the 3 screws and side airbag sensor assembly.

Torx wrench: T40 (Part No.09042-00020 or locally manufactured tool)

INSPECTION

1. VEHICLE NOT INVOLVED IN COLLISION

Do a diagnostic system check. (See page [DI-626](#))

2. VEHICLE INVOLVED IN COLLISION AND AIRBAG IS NOT DEPLOYED

Do a diagnostic system check. (See page [DI-626](#))

3. VEHICLE INVOLVED IN COLLISION AND AIRBAG IS DEPLOYED

Replace the side airbag sensor assembly. (See page [RS-69](#))

REPLACEMENT

REPLACEMENT REQUIREMENTS

In the following cases, replace the side airbag sensor assembly.

- If the side airbag sensor assembly has been deployed in a collision.
- If the side airbag sensor assembly has been found to be faulty in troubleshooting.
- If the side airbag sensor assembly has been dropped.

CAUTION:

For removal and installation of the side airbag sensor assembly, see page [RS-69](#) and [RS-72](#). Be sure to follow the correct procedure.

INSTALLATION

NOTICE:

- Never use SRS parts from another vehicle. When replacing parts, replace them with new ones.
- Never reuse the side airbag sensor assembly involved in a collision when the airbag has deployed.
- Never repair a sensor in order to reuse it.

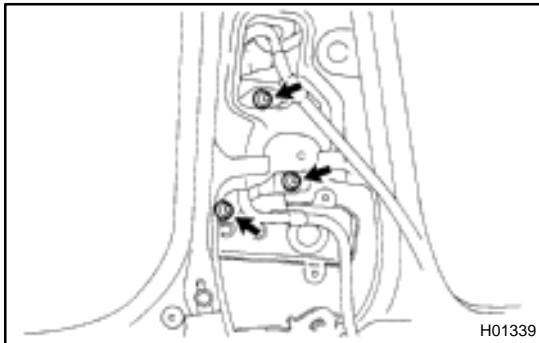

1. INSTALL SIDE AIRBAG SENSOR ASSEMBLY

- (a) Using a torx wrench, install the side airbag sensor assembly with the 3 screws.

Torx wrench: T40 (Part No.09042-00020 or locally manufactured tool)

Torque: 20 N·m (205 kgf·cm, 15 ft·lbf)

- (b) Connect the side airbag sensor assembly connector.

NOTICE:

- Connection of the connector is done after the sensor assembly has been installed. Make sure the sensor assembly is installed with the specified torque.
- If the sensor assembly has been dropped, or there are cracks, dents or other defects in the case, bracket or connector, replace the sensor assembly with a new one.
- When installing the sensor assembly, take care that the SRS wiring does not interfere with other parts and is not pinched between other parts.
- After installation, shake the sensor assembly to check that there is no looseness.

2. INSTALL FRONT SEAT OUTER BELT RETRACTOR (See page [BO-134](#))

- (a) Install the retractor with the 2 bolts.

Torque:

Upper bolt: 7.5 N·m (76 kgf·cm, 66 in.-lbf)

Lower bolt: 42 N·m (430 kgf·cm, 31 ft·lbf)

- (b) Connect the pretensioner connector.

3. INSTALL CENTER PILLAR LOWER GARNISH

4. INSTALL FRONT DOOR SCUFF PLATE



WIRE HARNESS AND CONNECTOR LOCATION

RS01V-11

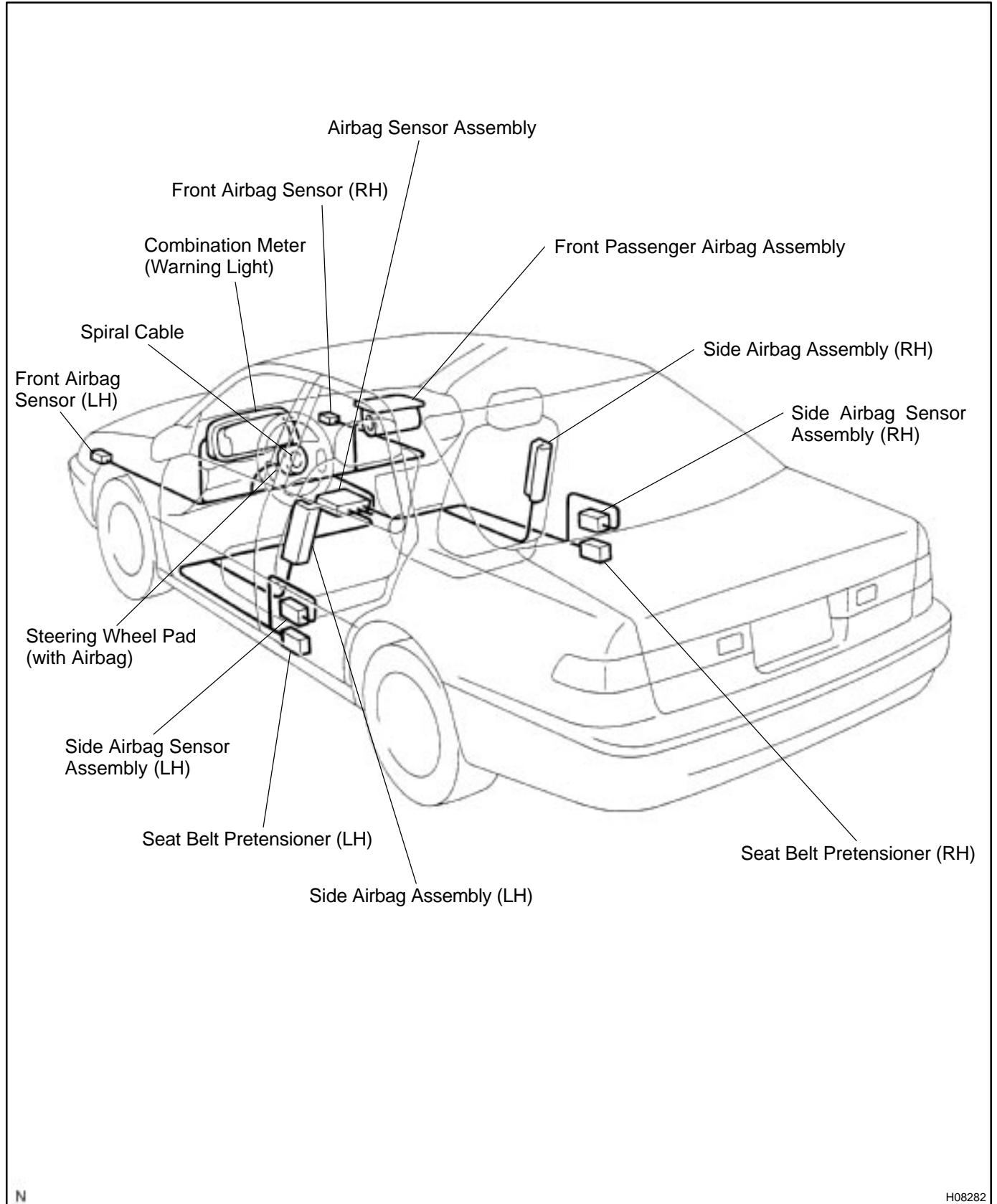

INSPECTION

HINT:

The SRS wire harness is integrated with the instrument panel wire harness assembly. All the connectors in the system are a standard yellow color.

1. VEHICLE NOT INVOLVED IN COLLISION

Do a diagnostic system check. (See page [DI-626](#))

2. VEHICLE INVOLVED IN COLLISION

- (a) Do a diagnostic system check. (See page [DI-626](#))
- (b) Check breaks in all wires of the SRS wire harness, and exposed conductors.
- (c) Check to see if the SRS wire harness connectors are cracked or chipped.

REPLACEMENT

In the following cases, replace the wire harness or connector.

- If any part of the SRS wire harness or any connector has been found to be faulty in troubleshooting.
- If any part of the SRS wire harness or any connector has been found to be faulty during checking items. (See page [RS-74](#))

CAUTION:

If the wire harness used in the SRS is damaged, replace the whole wire harness assembly.