

# STEERING SYSTEM

SR06B-01

## PRECAUTION

- ★ Care must be taken to replace parts properly because they could affect the performance of the steering system and result in a driving hazard.
- ★ The CAMRY is equipped with SRS (Supplemental Restraint System) such as the driver airbag and front passenger airbag. Failure to carry out service operation in the correct sequence could cause the SRS to unexpectedly deployed during servicing, possibly leading to a serious accident. Before servicing (including removal or installation of parts, inspection or replacement), be sure to read the precautionary notices in the RS section.

# TROUBLESHOOTING

SR06C-01

## PROBLEM SYMPTOMS TABLE

Use the table below to help you find the cause of the problem. The numbers indicate the priority of the likely cause of the problem. Check each part in the order shown. If necessary, repair or replace these parts.

Symptom	Suspect Area	See page
Hard steering	<ol style="list-style-type: none"> <li>1. Tires (Improperly inflated)</li> <li>2. Power steering fluid level (Low)</li> <li>3. Drive belt (Loose)</li> <li>4. Front wheel alignment (Incorrect)</li> <li>5. Steering system joints (Worn)</li> <li>6. Suspension arm ball joints (Worn)</li> <li>7. Steering column (Binding)</li> <li>8. Power steering vane pump</li> <li>9. Power steering gear</li> </ol>	<p>SA-2</p> <p>SR-5</p> <p>SR-3</p> <p>SA-4</p> <p>–</p> <p>SA-45</p> <p>–</p> <p>SR-18</p> <p>SR-31</p>
Poor return	<ol style="list-style-type: none"> <li>1. Tires (Improperly inflated)</li> <li>2. Front wheel alignment (Incorrect)</li> <li>3. Steering column (Binding)</li> <li>4. Power steering gear</li> </ol>	<p>SA-2</p> <p>SA-4</p> <p>–</p> <p>SR-31</p>
Excessive play	<ol style="list-style-type: none"> <li>1. Steering system joints (Worn)</li> <li>2. Suspension arm ball joints (Worn)</li> <li>3. Intermediate shaft, Sliding yoke (Worn)</li> <li>4. Front wheel bearing (Worn)</li> <li>5. Power steering gear</li> </ol>	<p>–</p> <p>SA-45</p> <p>–</p> <p>SA-10</p> <p>SR-31</p>
Abnormal noise	<ol style="list-style-type: none"> <li>1. Power steering fluid level (Low)</li> <li>2. Steering system joints (Worn)</li> <li>3. Power steering vane pump</li> <li>4. Power steering gear</li> </ol>	<p>SR-5</p> <p>–</p> <p>SR-18</p> <p>SR-31</p>

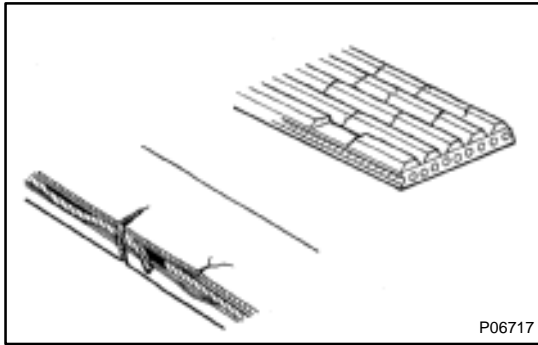

# DRIVE BELT INSPECTION

SR06D-01

## INSPECT DRIVE BELT

(a) Visually check the belt for excessive wear, frayed cords etc.

If any defect has been found, replace the drive belt.

**HINT:**

Cracks on the rib side of a belt are considered acceptable. If the belt has chunks missing from the ribs, it should be replaced.

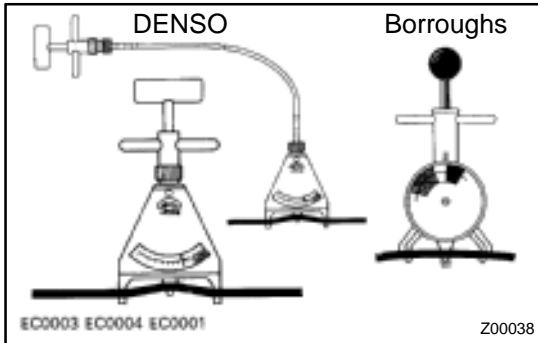

(b) Using a belt tension gauge, measure the belt tension.

Belt tension gauge:

DENSO BTG-20 (95506-00020)

Borroughs No. BT-33-73F

**5S-FE Engine:**

**Drive belt tension:**

**New belt: 95 – 145 lbf**

**Used belt: 60 – 100 lbf**

**1MZ-FE Engine:**

**Drive belt tension:**

**New belt: 150 – 185 lbf**

**Used belt: 95 – 135 lbf**

If the belt tension is not as specified, adjust it.

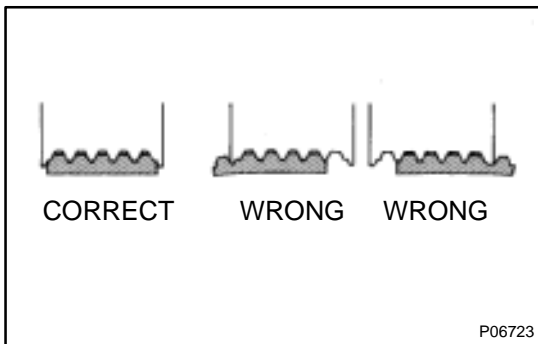

**HINT:**

- ★ "New belt" refers to a belt which has been used less than 5 minutes on a running engine.
- ★ "Used belt" refers to a belt which has been used on a running engine for 5 minutes or more.
- ★ After installing a belt, check that it fits properly in the ribbed grooves.
- ★ Check with your hand to confirm that the belt has not slipped out of the groove on the bottom of the pulley.
- ★ After installing a new belt, run the engine for about 5 minutes and recheck the belt tension.

## POWER STEERING FLUID BLEEDING

SR06E-01

1. **CHECK FLUID LEVEL**  
(See page [SR-5](#))
2. **JACK UP FRONT OF VEHICLE AND SUPPORT IT WITH STANDS**
3. **TURN STEERING WHEEL**

With the engine stopped, turn the wheel slowly from lock to lock several times.

4. **LOWER VEHICLE**
5. **START ENGINE**

Run the engine at idle for a few minutes.

6. **TURN STEERING WHEEL**
  - (a) With the engine idling, turn the wheel to left or right full lock and keep it there for 2–3 seconds, then turn the wheel to the opposite full lock and keep it there for 2–3 seconds.
  - (b) Repeat (a) several times.

7. **STOP ENGINE**

8. **CHECK FOR FOAMING OR EMULSIFICATION**

If the system has to be bled twice specifically because of foaming or emulsification, check for fluid leaks in the system.

9. **CHECK FLUID LEVEL**  
(See page [SR-5](#))

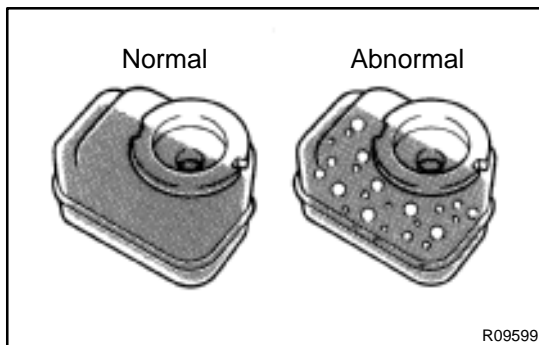

R09599

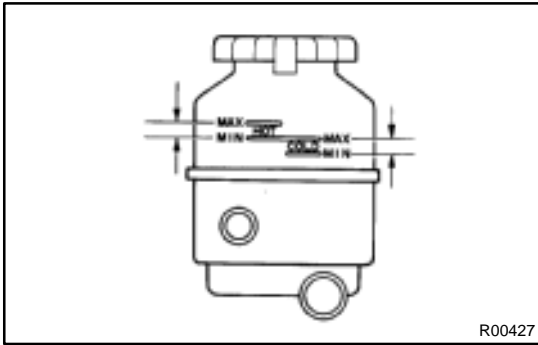

R00427

## INSPECTION

### 1. CHECK FLUID LEVEL

- (a) Keep the vehicle level.
- (b) With the engine stopped, check the fluid level in the oil reservoir.

If necessary, add fluid.

**Fluid: ATF DEXRON® II or III**

#### HINT:

Check that the fluid level is within the HOT LEVEL range on the reservoir. If the fluid is cold, check that it is within the COLD LEVEL range.

- (c) Start the engine and run it at idle.
- (d) Turn the steering wheel from lock to lock several times to boost fluid temperature.

**Fluid temperature: 80°C (176°F)**

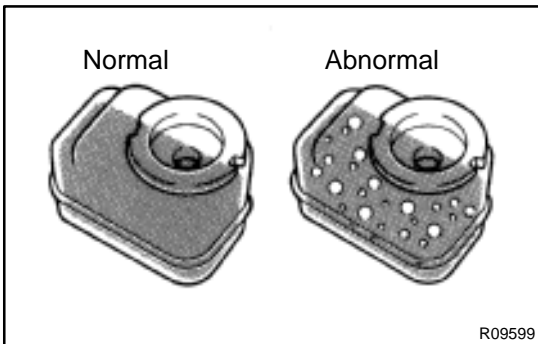

R09599

- (e) Check for foaming or emulsification. If there is foaming or emulsification, bleed power steering system.

(See page [SR-4](#))

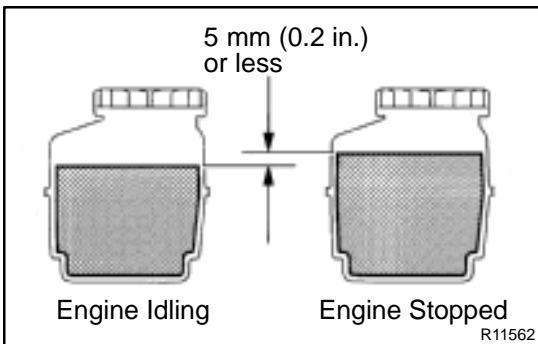

R11562

- (f) With the engine idling, measure the fluid level in the oil reservoir.

- (g) Stop the engine.

- (h) Wait a few minutes and remeasure the fluid level in the oil reservoir.

**Maximum fluid level rise: 5 mm (0.20 in.)**

If a problem is found, bleed power steering system.

(See page [SR-4](#))

- (i) Check the fluid level.

**2. CHECK STEERING FLUID PRESSURE**

- (a) Disconnect the pressure feed tube.  
(See page [SR-21](#))
- (b) Connect SST, as shown below.  
SST 09640-10010 (09641-01010, 09641-01030, 09641-01060)

**NOTICE:**

**Check that the valve of the SST is in the open position.**

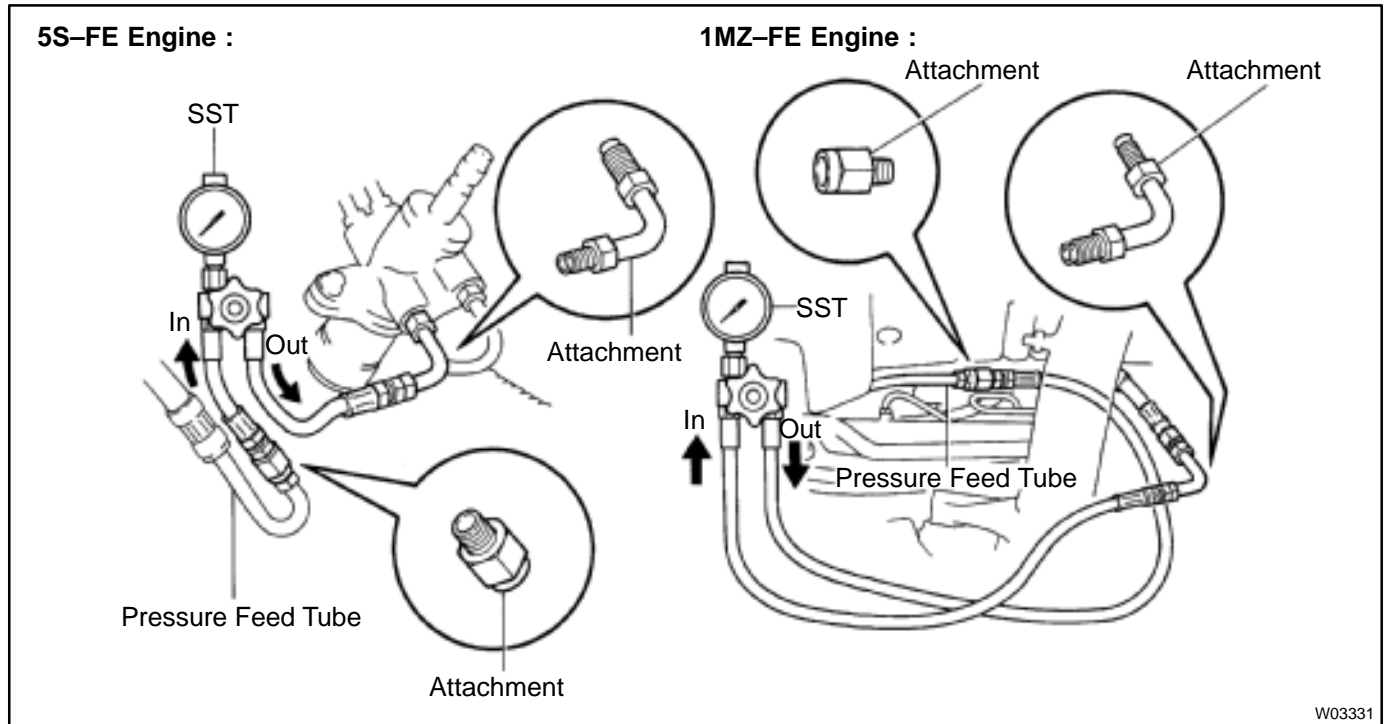

W03331

- (c) Bleed the power steering system.  
(See page [SR-4](#))
- (d) Start the engine and run it at idle.
- (e) Turn the steering wheel from lock to lock several times to boost fluid temperature.

**Fluid temperature: 80 °C (176 °F)**

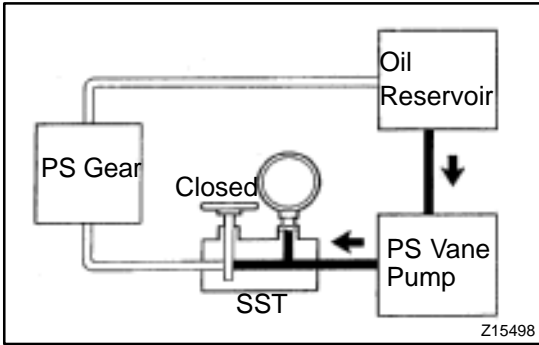

- (f) With the engine idling, close the valve of the SST and observe the reading on the SST.  
**Minimum fluid pressure:**  
**7,845 kPa (80 kgf-cm<sup>2</sup>, 1,138 psi)**

**NOTICE:**

- ★ Do not keep the valve closed for more than 10 seconds.
- ★ Do not let the fluid temperature become too high.

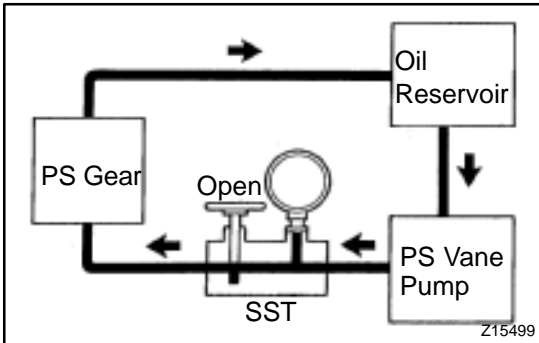

- (g) With the engine idling, open the valve fully.  
 (h) Measure the fluid pressure at engine speeds of 1,000 rpm and 3,000 rpm.

**Difference fluid pressure:**  
**490 kPa (5 kgf-cm<sup>2</sup>, 71 psi) or less**

**NOTICE:**

**Do not turn the steering wheel.**

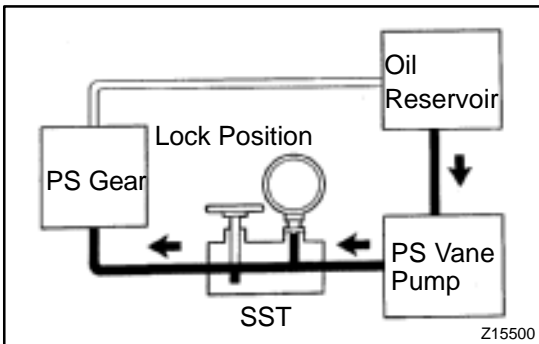

- (i) With the engine idling and valve fully opened, turn the steering wheel to full lock.  
**Minimum fluid pressure:**  
**7,845 kPa (80 kgf-cm<sup>2</sup>, 1,138 psi)**

**NOTICE:**

- ★ Do not maintain lock position for more than 10 seconds.
  - ★ Do not let the fluid temperature become too high.
- (j) Disconnect the SST.  
 (k) Connect the pressure feed tube.  
 (See page [SR-28](#))  
 (l) Bleed the power steering system.  
 (See page [SR-4](#))

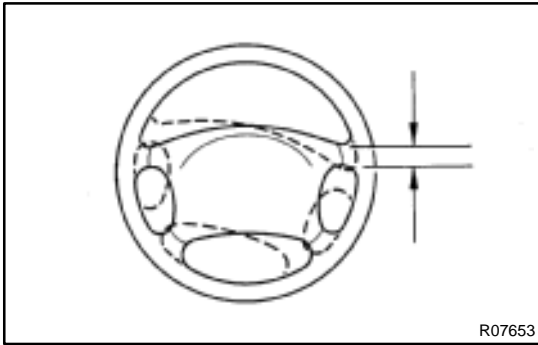

## STEERING WHEEL INSPECTION

SR06G-01

### 1. CHECK STEERING WHEEL FREEPLAY

With the vehicle stopped and tires facing straight ahead, rock the steering wheel gently back and forth with light finger pressure.

Freeplay should not exceed the maximum.

**Maximum freeplay: 30 mm (1.18 in.)**

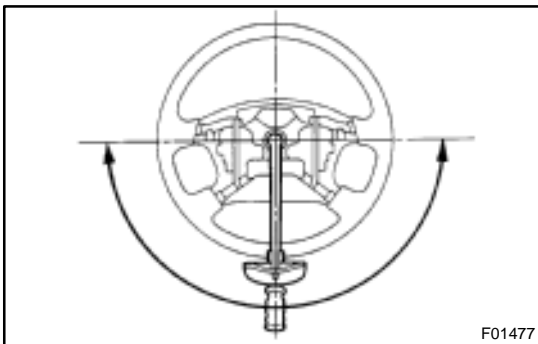

### 2. CHECK STEERING EFFORT

- (a) Center the steering wheel.
- (b) Remove the steering wheel pad.  
(See page [SR-11](#))
- (c) Start the engine and run it at idle.
- (d) Measure the steering effort in both directions.

**Reference: 5.9 N·m (60 kgf·cm, 52 in.-lbf)**

#### HINT:

Be sure to consider the tire type, pressure and contact surface before making your diagnosis.

- (e) Torque the steering wheel set nut.  
**Torque: 35 N·m (360 kgf·cm, 26 ft·lbf)**
- (f) Install the steering wheel pad.  
(See page [SR-16](#))



# TILT STEERING COLUMN COMPONENTS

SR06H-03

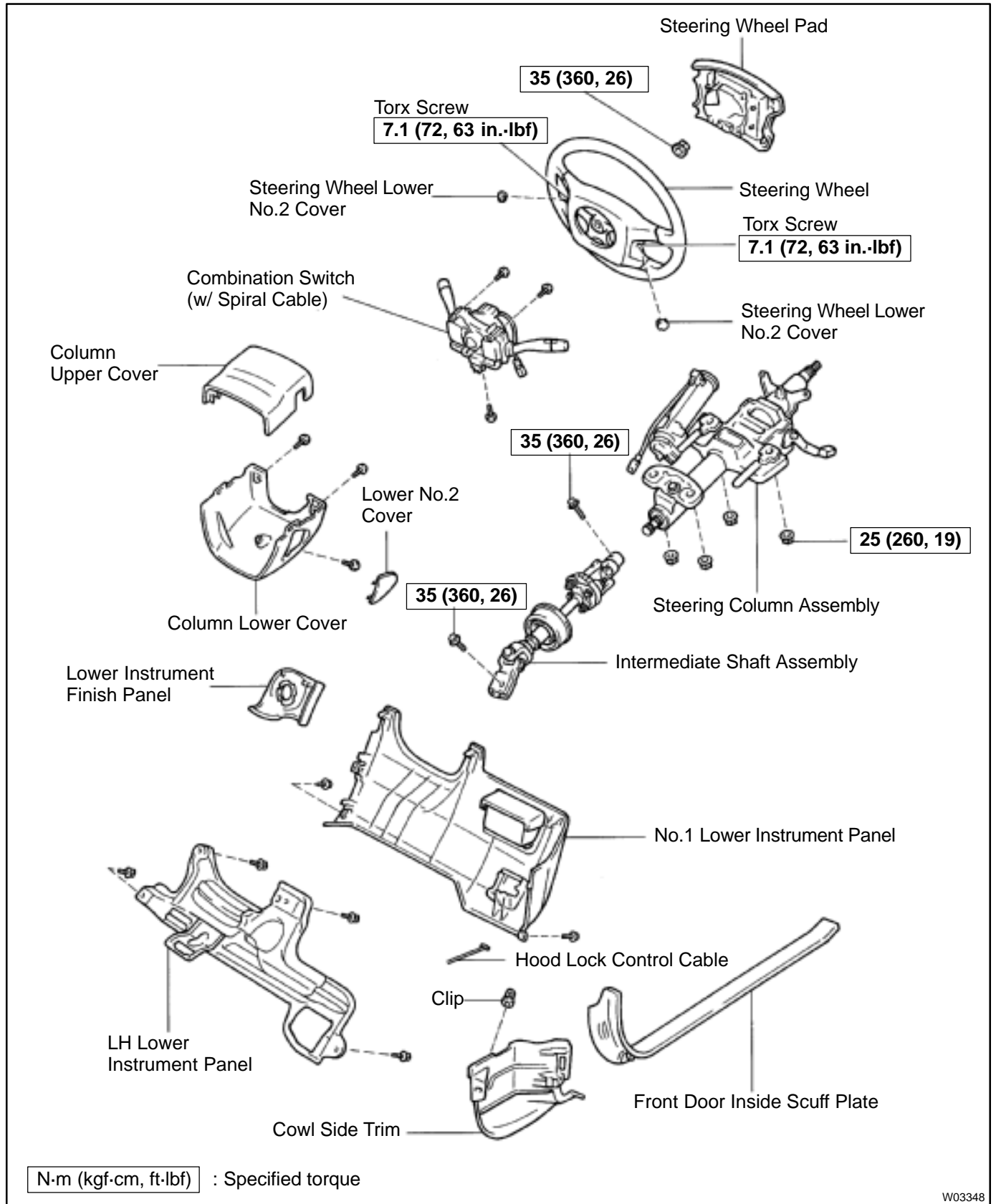

W03348

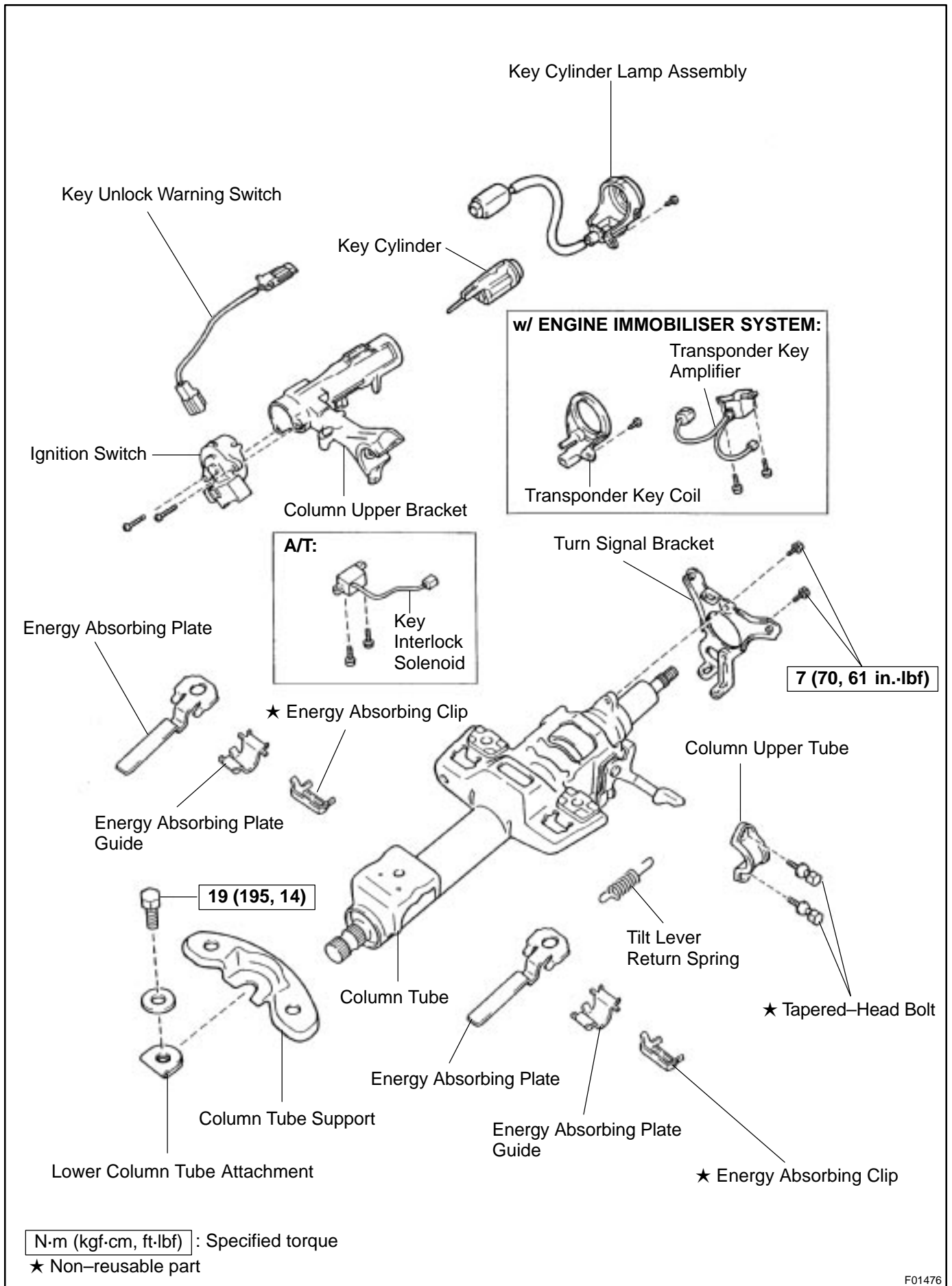

## REMOVAL

### 1. REMOVE STEERING WHEEL PAD

#### NOTICE:

- ★ If the airbag connector is disconnected with the ignition switch at ON or ACC, DTCs will be recorded.
- ★ Never use airbag parts from another vehicle. When replacing parts, replace with new ones.

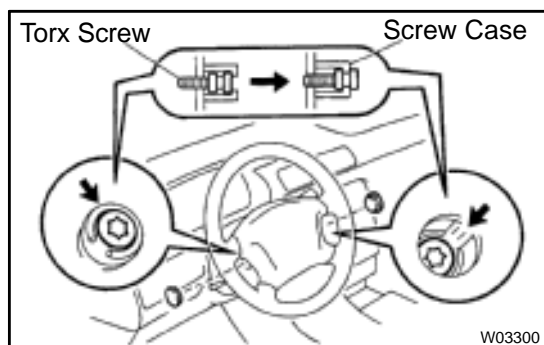

- (a) Place the front wheels facing straight ahead.
- (b) Remove the 2 steering wheel lower No.2 covers.
- (c) Using a torx socket wrench, loosen the 2 torx screws.

#### HINT:

Loosen the 2 screws until the groove along the screw circumference catches on the screw case.

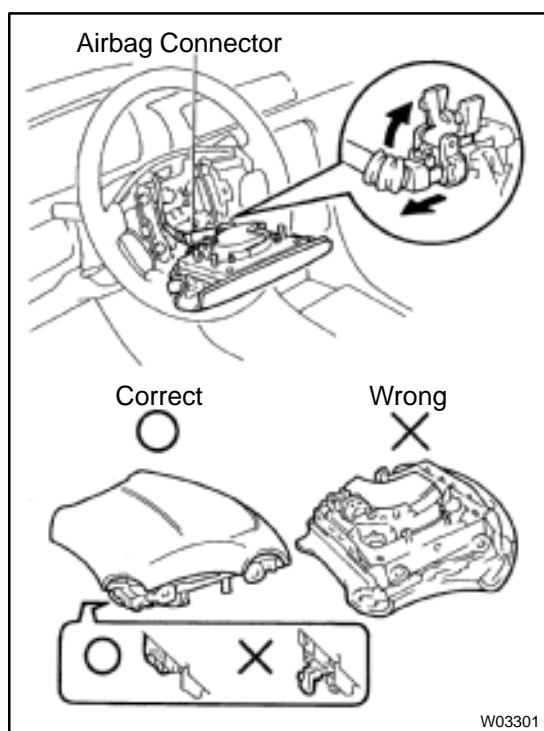

- (d) Pull the pad out from the steering wheel and disconnect the airbag connector.

#### CAUTION:

- ★ When storing the wheel pad, keep the upper surface of the pad facing upward.
- ★ Never disassemble the wheel pad.

#### NOTICE:

When removing the wheel pad, take care not to pull the airbag wire harness.

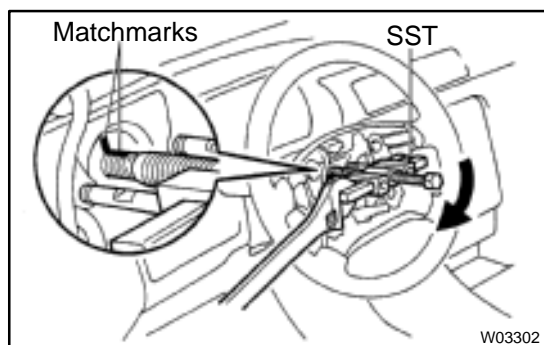

### 2. REMOVE STEERING WHEEL

- (a) Disconnect the connector.
- (b) Remove the steering wheel set nut.
- (c) Place matchmarks on the steering wheel and main shaft assembly.
- (d) Using SST, remove the wheel.

SST 09950-50012 (09951-05010, 09952-05010, 09953-05020, 09954-05020)

**3. REMOVE UPPER AND LOWER COLUMN COVERS**

- (a) Remove the lower No.2 cover from the lower cover.
- (b) Remove the 3 screws.

**4. REMOVE FRONT DOOR INSIDE SCUFF PLATE****5. REMOVE COWL SIDE TRIM**

Remove the clip.

**6. REMOVE No.1 LOWER INSTRUMENT PANEL**

- (a) Remove the 2 screws.
- (b) Disconnect the hood lock control cable.

**7. REMOVE LH LOWER INSTRUMENT PANEL**

Remove the 4 bolts.

**8. REMOVE LOWER INSTRUMENT FINISH PANEL****9. REMOVE COMBINATION SWITCH WITH SPIRAL CABLE**

- (a) Disconnect the 3 connectors.
- (b) Disconnect the airbag connector.
- (c) Remove the 3 screws.

**10. REMOVE SPIRAL CABLE**

(See page [BE-23](#))

**NOTICE:**

Do not disassemble the cable or apply oil to it.

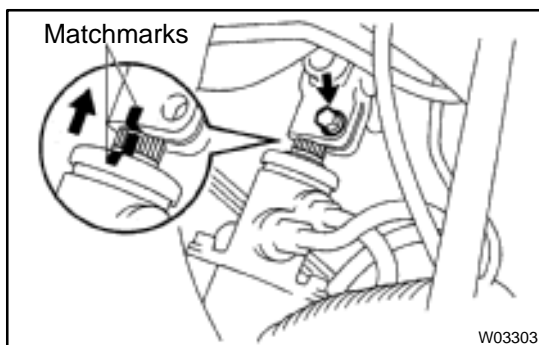
**11. DISCONNECT INTERMEDIATE SHAFT ASSEMBLY**

- (a) Place matchmarks on the intermediate shaft and control valve shaft.
- (b) Remove the bolt.

**12. REMOVE INTERMEDIATE SHAFT ASSEMBLY**

Remove the bolt.

**13. REMOVE STEERING COLUMN ASSEMBLY**

- (a) Disconnect the connectors.
- (b) Remove the 4 column assembly set nuts.

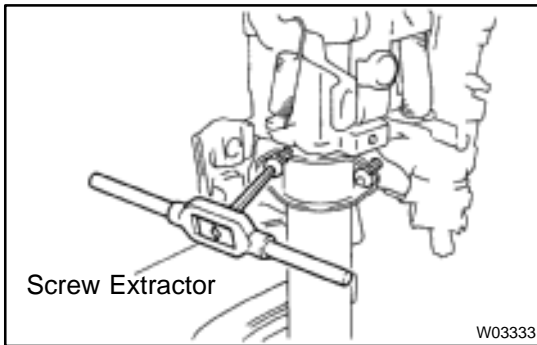

## DISASSEMBLY

### NOTICE:

When using a vise, do not overtighten it.

1. **w/ ENGINE IMMOBILISER SYSTEM:  
REMOVE TRANSPONDER KEY COIL WITH KEY CYLINDER LAMP ASSEMBLY**

Remove the screw.

2. **w/ ENGINE IMMOBILISER SYSTEM:  
REMOVE KEY CYLINDER LAMP ASSEMBLY**

Remove the lamp assembly from the key coil.

3. **w/o ENGINE IMMOBILISER SYSTEM:  
REMOVE KEY CYLINDER LAMP ASSEMBLY**

Remove the screw.

4. **REMOVE COLUMN UPPER BRACKET AND COLUMN UPPER CLAMP**

- (a) Using a centering punch, mark the center of the 2 tapered-head bolts.
- (b) Using a 3–4 mm (0.12–0.16 in.) drill, drill into the 2 bolts.
- (c) Using a screw extractor, remove the 2 bolts.

5. **REMOVE TURN SIGNAL BRACKET**

Remove the 2 bolts.

6. **REMOVE TILT LEVER RETURN SPRING**

7. **REMOVE COLUMN TUBE SUPPORT**

- (a) Remove the bolt and washer.
- (b) Remove the tube support with lower column tube attachment.
- (c) Remove the tube attachment from the tube support.

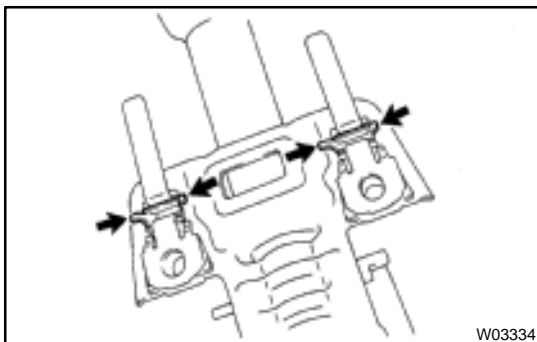

8. **REMOVE 2 ENERGY ABSORBING PLATES**

- (a) Using pliers, remove the energy absorbing clip.
- (b) Remove the energy absorbing plate, energy absorbing plate guide.

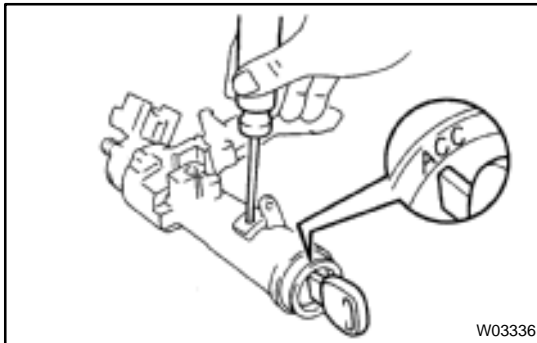
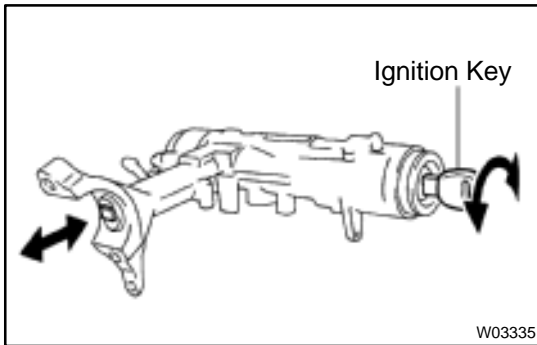

## INSPECTION

### 1. INSPECT STEERING LOCK OPERATION

Check that the steering lock mechanism operates properly.

### 2. IF NECESSARY, REPLACE KEY CYLINDER

- (a) Place the ignition key at the ACC position.
- (b) Push down the stop pin with a screwdriver, and pull out the cylinder.
- (c) Install a new cylinder.

HINT:

Make sure the key is at the ACC position.

### 3. INSPECT IGNITION SWITCH

(See page [BE-14](#))

### 4. IF NECESSARY, REPLACE IGNITION SWITCH

- (a) Remove the 2 screws.
- (b) Install a new switch with the 2 screws.

### 5. INSPECT KEY UNLOCK WARNING SWITCH

(See page [BE-14](#))

### 6. IF NECESSARY, REPLACE KEY UNLOCK WARNING SWITCH

- (a) Slide out the switch.
- (b) Install a new switch.

### 7. A/T:

#### INSPECT KEY INTERLOCK SOLENOID

(A140E: See page [AX-13](#))

(A541E: See page [AX-17](#))

### 8. A/T:

#### IF NECESSARY, REPLACE KEY INTERLOCK SOLENOID

- (a) Remove the 2 screws.
- (b) Install a new solenoid with the 2 screws.

### 9. w/ ENGINE IMMOBILISER SYSTEM:

#### INSPECT TRANSPONDER KEY COIL

(See page [BE-128](#))

### 10. w/ ENGINE IMMOBILISER SYSTEM:

#### IF NECESSARY, REPLACE TRANSPONDER KEY COIL

### 11. w/ ENGINE IMMOBILISER SYSTEM:

#### IF NECESSARY, REPLACE TRANSPONDER KEY AMPLIFIER

- (a) Remove the 2 screws.
- (b) Install a new key amplifier with the 2 screws.

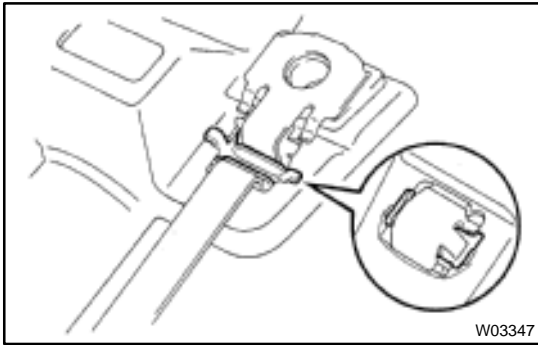

## REASSEMBLY

### NOTICE:

When using a vise, do not overtighten it.

#### 1. INSTALL 2 ENERGY ABSORBING PLATES

- (a) Install the energy absorbing plate guide and absorbing plate.
- (b) Install the new energy absorbing clip.

#### 2. INSTALL COLUMN TUBE SUPPORT

- (a) Install the tube attachment to the tube support.
- (b) Torque the bolt and washer.

**Torque: 19 N·m (195 kgf-cm, 14 ft-lbf)**

#### 3. INSTALL TILT LEVER RETURN SPRING

#### 4. INSTALL TURN SIGNAL BRACKET

Torque the 2 bolts.

**Torque: 7 N·m (70 kgf-cm, 61 in.-lbf)**

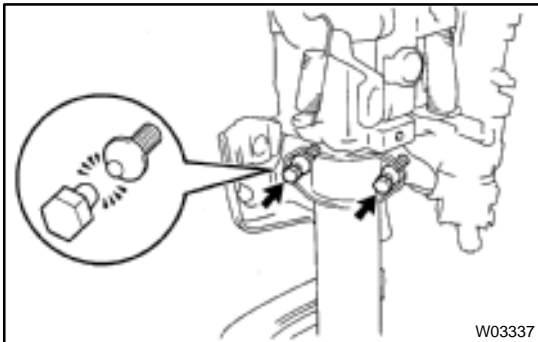

#### 5. INSTALL COLUMN UPPER BRACKET AND COLUMN UPPER CLAMP

Tighten the 2 new tapered-head bolts until the bolt heads break off.

#### 6. w/ ENGINE EMMOBILISER SYSTEM: INSTALL KEY CYLINDER LAMP ASSEMBLY

Install the lamp assembly to the key coil.

#### 7. w/ ENGINE EMMOBILISER SYSTEM: INSTALL TRANSPONDER KEY COIL WITH KEY CYLINDER LAMP ASSEMBLY

Tighten the screw.

#### 8. w/o ENGINE EMMOBILISER SYSTEM: INSTALL KEY CYLINDER LAMP ASSEMBLY

Tighten the screw.

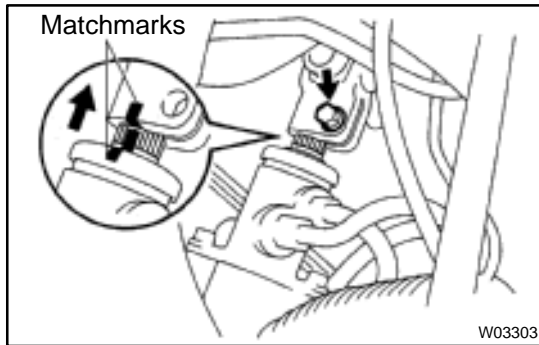

## INSTALLATION

### 1. INSTALL STEERING COLUMN ASSEMBLY

- (a) Torque the 4 column assembly set nuts.  
**Torque: 25 N·m (260 kgf·cm, 19 ft·lbf)**

- (b) Connect the connectors.

### 2. INSTALL INTERMEDIATE SHAFT ASSEMBLY

Torque the bolt.

**Torque: 35 N·m (360 kgf·cm, 26 ft·lbf)**

### 3. CONNECT INTERMEDIATE SHAFT ASSEMBLY

- (a) Align the matchmarks on the intermediate shaft and control valve shaft.

- (b) Torque the bolt.

**Torque: 35 N·m (360 kgf·cm, 26 ft·lbf)**

### 4. INSTALL SPIRAL CABLE

(See page [BE-23](#))

### 5. INSTALL COMBINATION SWITCH WITH SPIRAL CABLE

- (a) Tighten the 3 screws.

- (b) Connect the airbag connector.

- (c) Connect the 3 connectors.

### 6. INSTALL LOWER INSTRUMENT FINISH PANEL

### 7. INSTALL LH LOWER INSTRUMENT PANEL

Tighten the 4 bolts.

### 8. INSTALL No.1 LOWER INSTRUMENT PANEL

- (a) Connect the hood lock control cable.

- (b) Tighten the 2 screws.

### 9. INSTALL COWL SIDE TRIM

Install the clip.

### 10. INSTALL FRONT DOOR INSIDE SCUFF PLATE

### 11. INSTALL UPPER AND LOWER COLUMN COVERS

- (a) Tighten the 3 screws.

- (b) Install the lower No.2 cover to the lower cover.

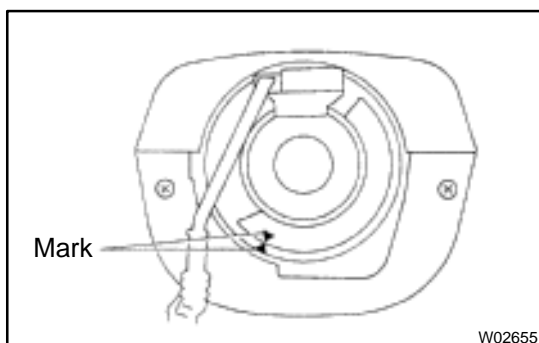

### 12. CENTER SPIRAL CABLE

- (a) Check that the front wheels are facing straight ahead.

- (b) Turn the cable counterclockwise by hand until it becomes harder to turn the cable.

- (c) Then rotate the cable clockwise about 3 turns to align the mark.

**HINT:**

The cable will rotate about 3 turns to either left or right of the center.



**13. INSTALL STEERING WHEEL**

- (a) Align the matchmarks on the wheel and main shaft.
- (b) Torque the wheel set nut.

**Torque: 35 N·m (360 kgf·cm, 26 ft·lbf)**

- (c) Connect the connector.

**14. INSTALL STEERING WHEEL PAD****NOTICE:**

- ★ **Make sure the wheel pad is installed to the specified torque.**
- ★ **If the wheel pad has been dropped, or there are cracks, dents or other defects in the case or connector, replace the wheel pad with a new one.**
- ★ **When installing the wheel pad, take care that the wirings do not interfere with other parts and are not pinched between other parts.**

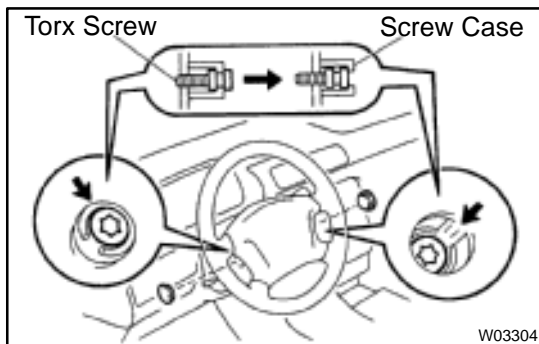

- (a) Connect the airbag connector.
- (b) Install the pad after confirming that the circumference groove of the torx screw is caught on the screw case.
- (c) Using a torx socket wrench, torque the 2 screws.  
**Torque: 7.1 N·m (72 kgf·cm, 63 in·lbf)**
- (d) Install the 2 steering wheel lower No.2 covers.

**15. CHECK STEERING WHEEL CENTER POINT**

# POWER STEERING VANE PUMP COMPONENTS

SR06N-03

5S-FE Engine :

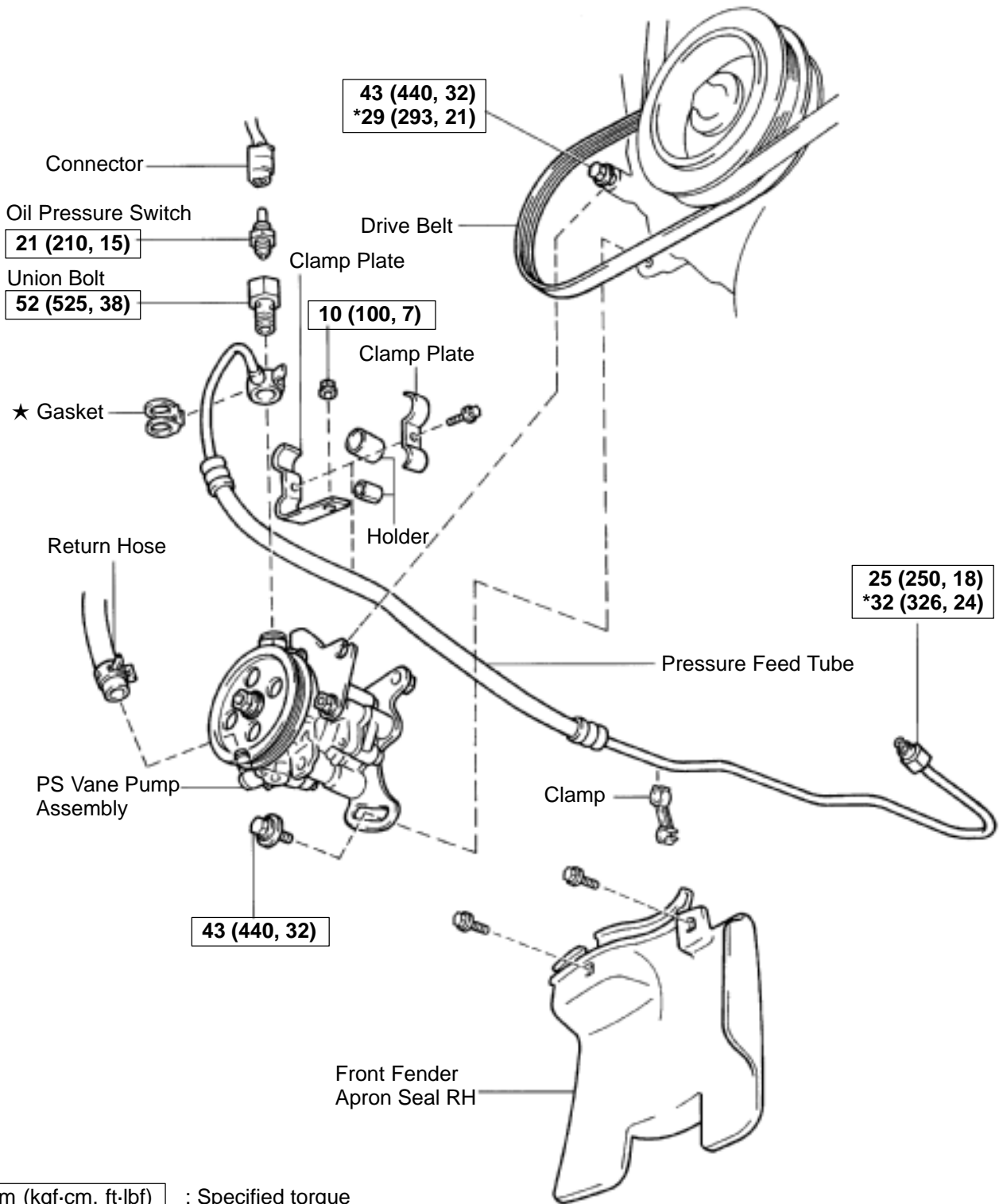

N·m (kgf·cm, ft·lbf) : Specified torque

★ Non-reusable part

\* For use with SST

W03364

1MZ-FE Engine :

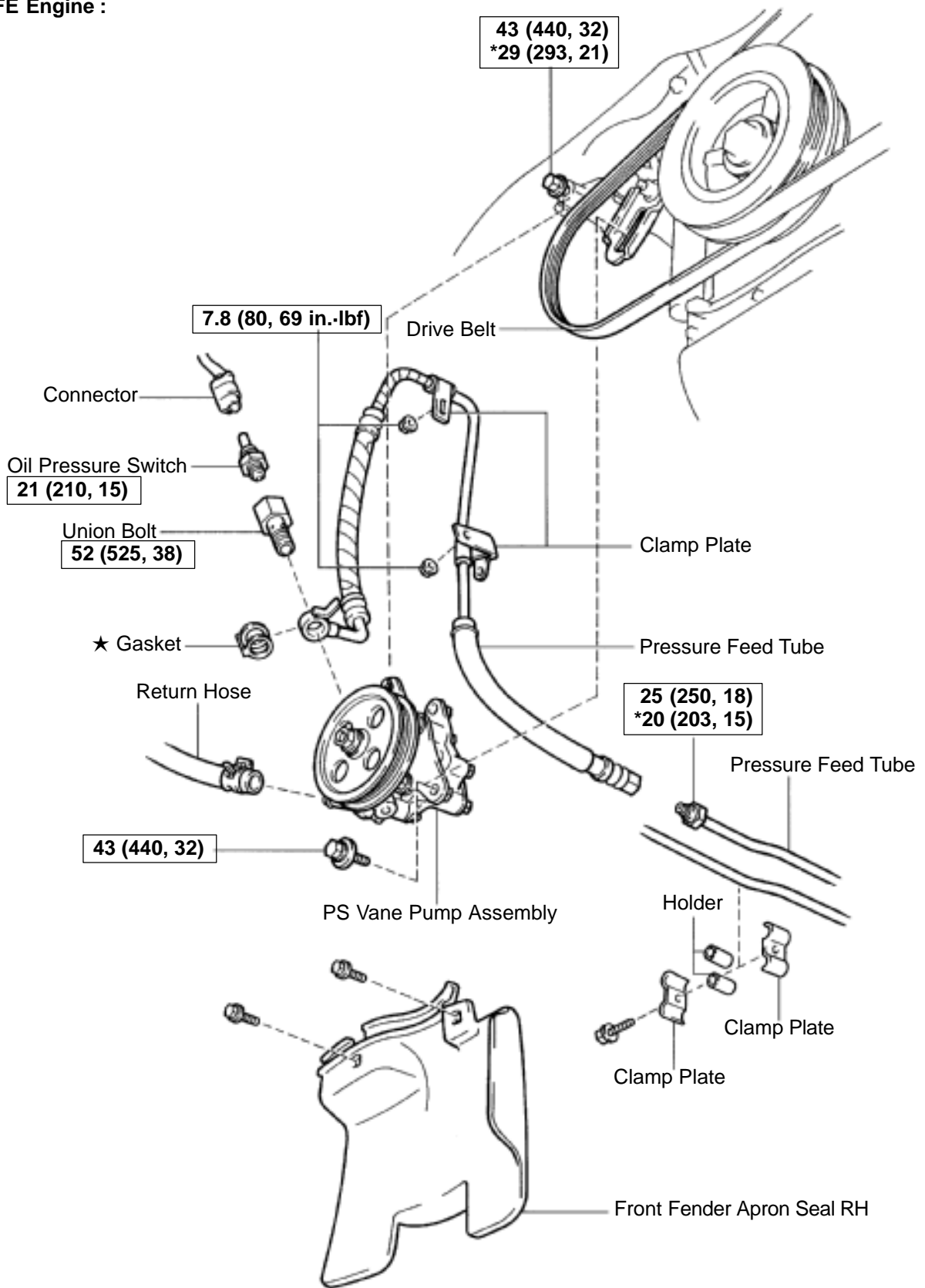

N·m (kgf·cm, ft·lbf) : Specified torque

★ Non-reusable part

\* For use with SST

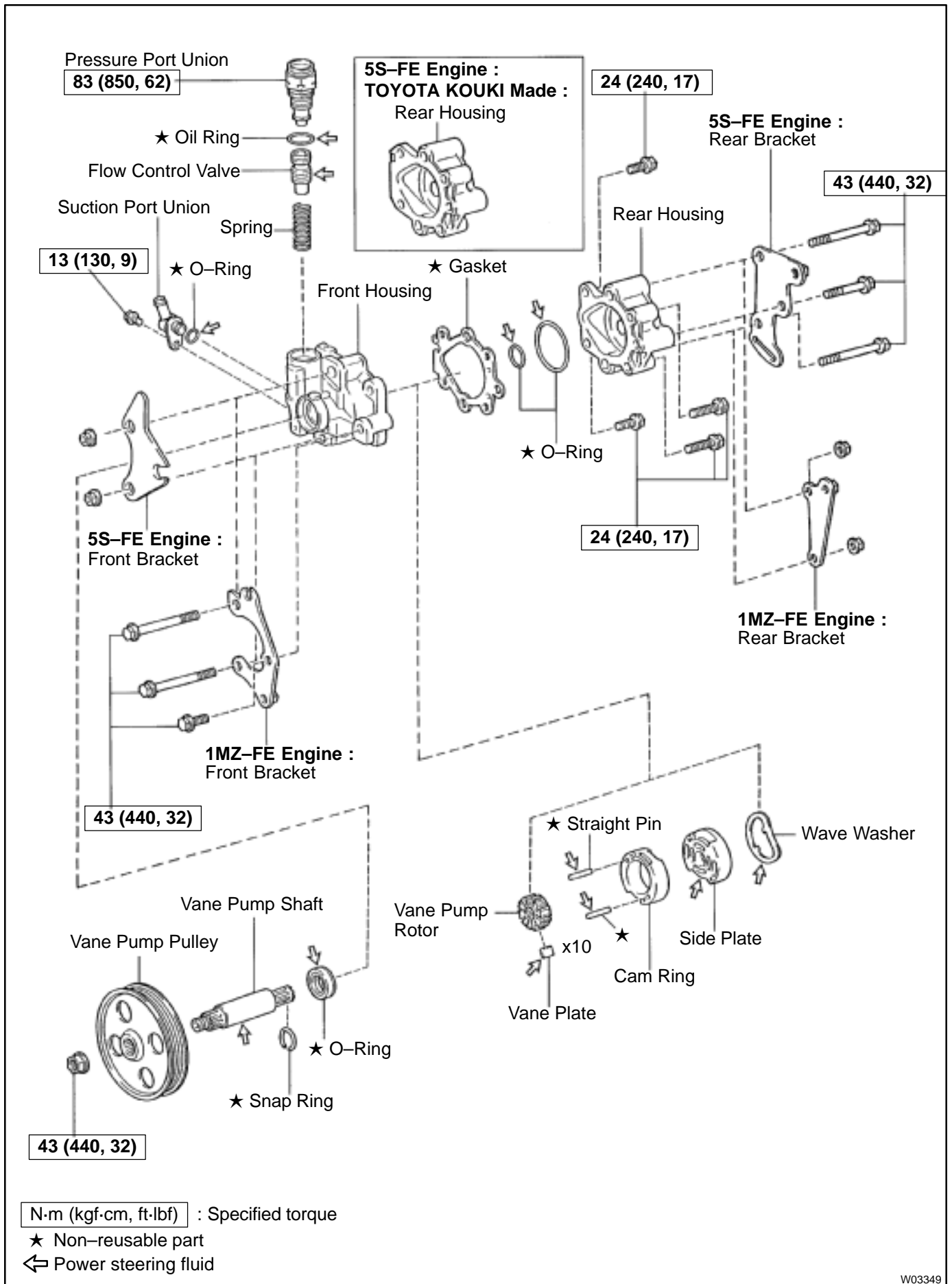

W03349

## REMOVAL

### 1. REMOVE FRONT FENDER APRON SEAL RH

Remove the 2 bolts.

### 2. DISCONNECT RETURN HOSE

#### NOTICE:

Take care not to spill fluid on the drive belt.

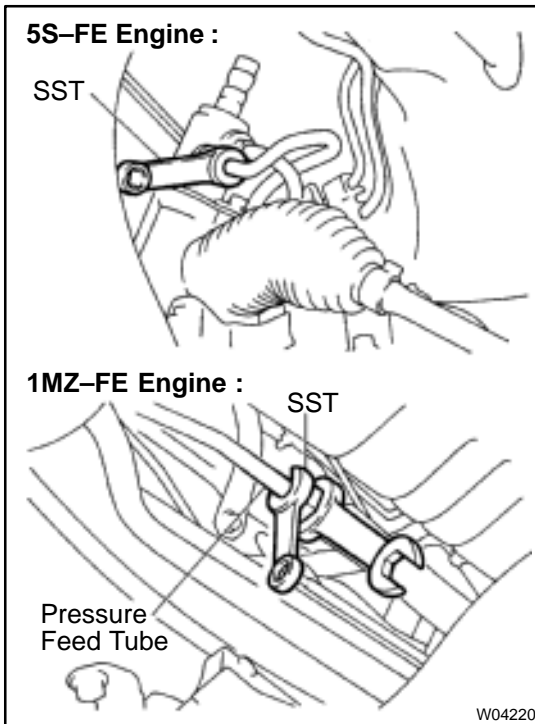

### 3. DISCONNECT PRESSURE FEED TUBE

- (a) 5S-FE Engine:  
Remove the clamp plate set bolt and nut.
- (b) 5S-FE Engine:  
Remove the 2 clamp plates and 2 holders from the tube.
- (c) 5S-FE Engine:  
Remove the clamp from the tube.
- (d) 1MZ-FE Engine:  
Remove the 2 clamp plate set nuts.
- (e) 1MZ-FE Engine:  
Remove the bolt.
- (f) 1MZ-FE Engine:  
Remove the 2 clamp plates and 2 holders from the tube.
- (g) 5S-FE and 1MZ-FE Engines:  
Using SST, disconnect the tube.  
SST 09631-22020

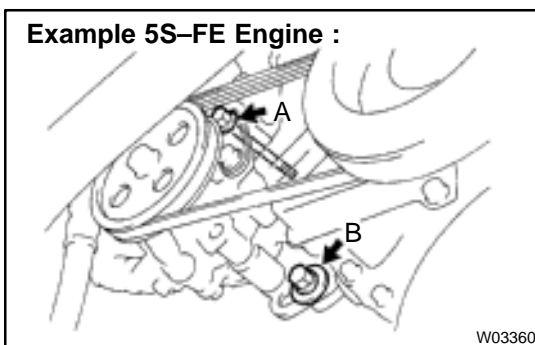

### 4. REMOVE DRIVE BELT

Loosen the 2 (A and B) bolts.

### 5. REMOVE PS VANE PUMP ASSEMBLY WITH PRESSURE FEED TUBE

- (a) Disconnect the connector from the oil pressure switch.
- (b) Loosen bolt A sufficiently so that pump assembly can be removed.

#### HINT:

Bolt A cannot be removed.

### 6. REMOVE PRESSURE FEED TUBE

- (a) Remove the oil pressure switch from the union bolt.

#### NOTICE:

**Be careful not to drop the switch.**

If the switch is dropped or strongly damaged, replace it with a new one.

- (b) Remove the union bolt and gasket.

Example 5S-FE Engine :

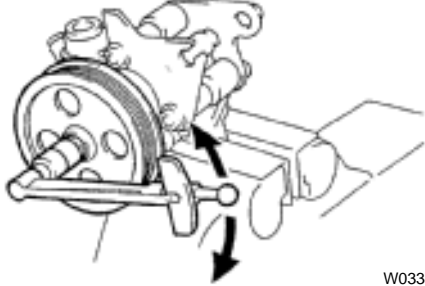

W03338

## DISASSEMBLY

### NOTICE:

When using a vise, do not overtighten it.

1. **MEASURE PS VANE PUMP ROTATING TORQUE**
  - (a) Check that the pump rotates smoothly without abnormal noise.
  - (b) Using a torque wrench, check the pump rotating torque.  
**5S-FE and 1MZ-FE Engines:**  
**Rotating torque:**  
**0.3 N·m (2.8 kgf·cm, 2.4 in.-lbf) or less**

Example 5S-FE Engine :

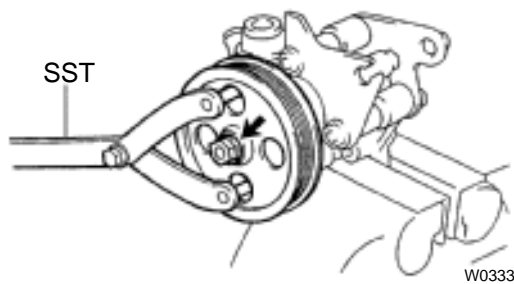

W03339

2. **REMOVE VANE PUMP PULLEY**

Using SST, to stop the pulley rotating, remove the nut.

SST 09960-10010 (09962-01000, 09963-01000)

3. **REMOVE FRONT AND REAR BRACKETS**

Remove the 3 bolts and 2 nuts.

4. **REMOVE SUCTION PORT UNION**

- (a) Remove the bolt.
- (b) Remove the O-ring from the union.

5. **REMOVE PRESSURE PORT UNION, FLOW CONTROL VALVE AND SPRING**

Remove the O-ring from the union.

6. **REMOVE REAR HOUSING**

- (a) Remove the 4 bolts.
- (b) Remove the 2 O-rings from the housing.

7. **REMOVE WAVE WASHER**

8. **REMOVE SIDE PLATE**

9. **REMOVE GASKET**

10. **REMOVE CAM RING, 10 VANE PLATES AND VANE PUMP ROTOR**

Using a screwdriver, remove the snap ring from the vane pump shaft.

### NOTICE:

Take care not to drop the plate.

11. **REMOVE VANE PUMP SHAFT**

12. **REMOVE STRAIGHT PINS**

Remove the 2 pins from the front housing.

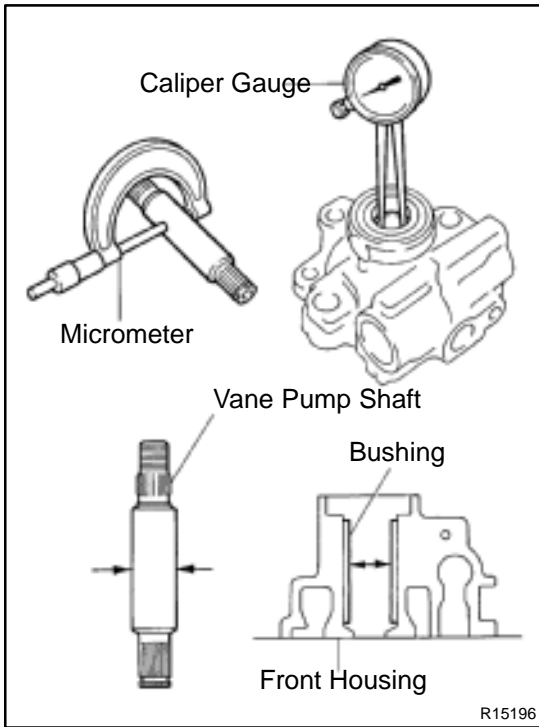

## INSPECTION

### NOTICE:

When using a vise, do not overtighten it.

### 1. CHECK OIL CLEARANCE BETWEEN VANE PUMP SHAFT AND BUSHING

Using a micrometer and caliper gauge, measure the oil clearance.

**5S-FE and 1MZ-FE Engines:**

**Standard clearance:**

**0.03 – 0.05 mm (0.0012 – 0.0020 in.)**

**Maximum clearance: 0.07 mm (0.0028 in.)**

If it is more than the maximum, replace the front housing and vane pump shaft.

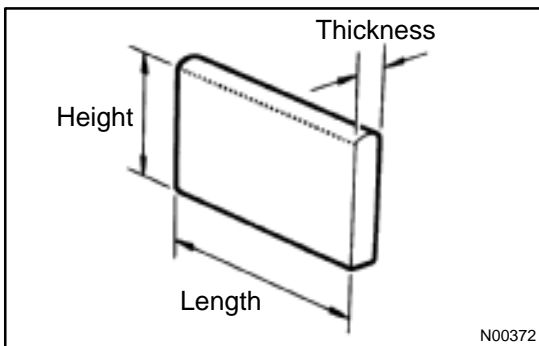

### 2. INSPECT VANE PUMP ROTOR AND VANE PLATES

(a) Using a micrometer, measure the height, thickness and length of the plates.

**5S-FE and 1MZ-FE Engines:**

**Minimum height: 8.6 mm (0.339 in.)**

**Minimum thickness: 1.397 mm (0.0550 in.)**

**Minimum length: 14.991 mm (0.5902 in.)**

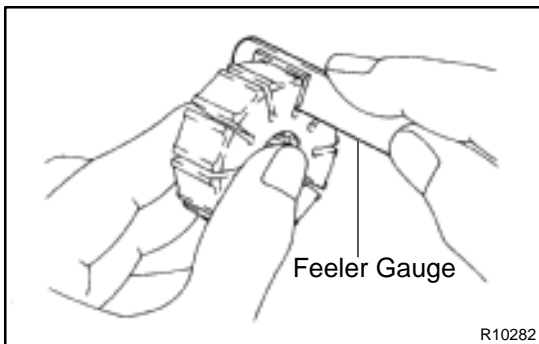

(b) Using a feeler gauge, measure the clearance between the rotor groove and plate.

**5S-FE and 1MZ-FE Engines:**

**Maximum clearance: 0.035 mm (0.0014 in.)**

If it is more than the maximum, replace the plate and/or rotor with one having the same mark stamped on the cam ring.

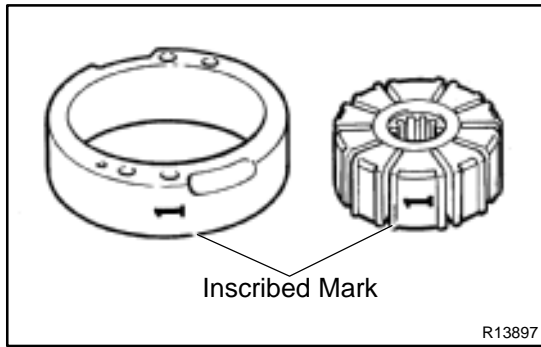

**5S-FE and 1MZ-FE Engines:  
Inscribed mark: 1, 2, 3, 4 or None**

**HINT:**

There are 5 vane lengths with the following rotor and cam ring marks:

**5S-FE and 1MZ-FE Engines:**

Rotor and cam ring mark	Vane plate part number	Vane plate length mm (in.)
None	44345-26010	14.999-15.001 (0.59051-0.59059)
1	44345-26020	14.997-14.999 (0.59043-0.59051)
2	44345-26030	14.995-14.997 (0.59035-0.59043)
3	44345-26040	14.993-14.995 (0.59027-0.59035)
4	44345-26050	14.991-14.993 (0.59020-0.59027)

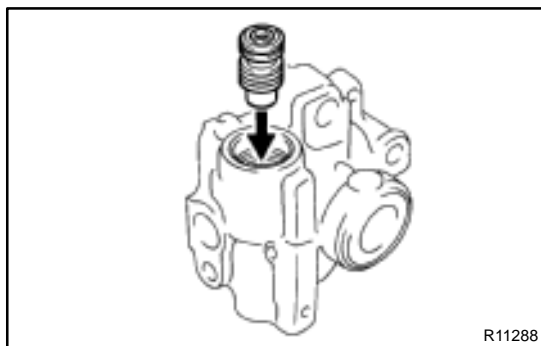

**3. INSPECT FLOW CONTROL VALVE**

- (a) Coat the valve with power steering fluid and check that it falls smoothly into the valve hole by its own weight.

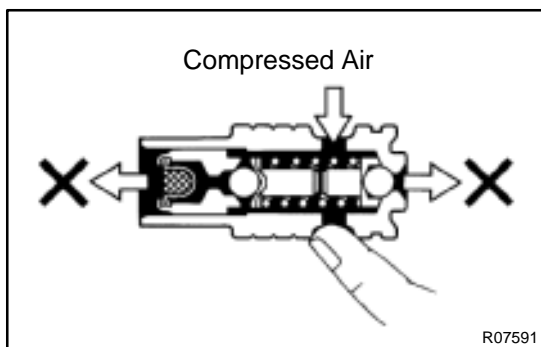

- (b) Check the valve for leakage. Close one of the holes and apply 392-490 kPa (4-5 kgf/cm<sup>2</sup>, 57-71 psi) of compressed air into the opposite side, and confirm that air does not come out from the end holes.

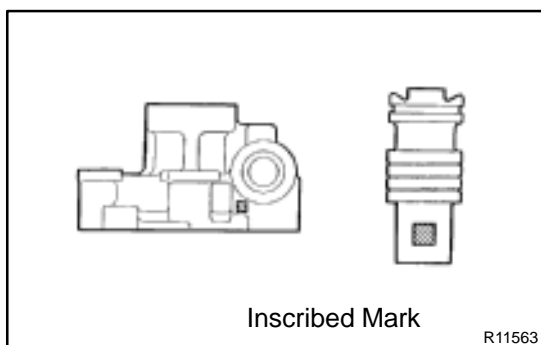

If necessary, replace the valve with one having the same letter as inscribed on the front housing.

**5S-FE and 1MZ-FE Engines:  
Inscribed mark: A, B, C, D, E or F**



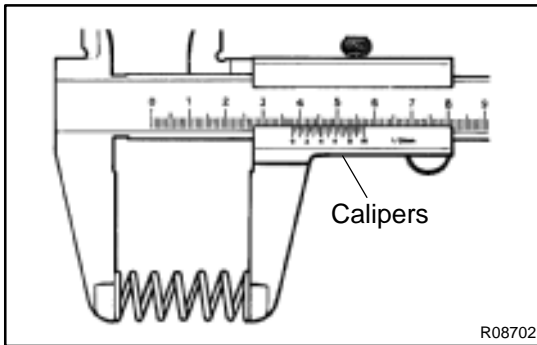

#### 4. INSPECT SPRING

Using a calipers, measure the free length of the spring.

**5S-FE and 1MZ-FE Engines:**

**Minimum free length: 32.3 mm (1.272 in.)**

If it is not within the specification, replace the spring.

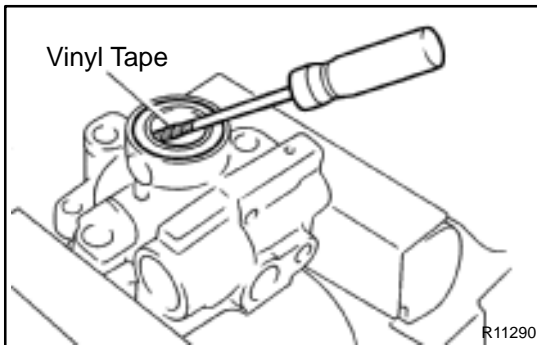

#### 5. IF NECESSARY, REPLACE OIL SEAL

- (a) Using a screwdriver with vinyl tape wound around its tip, remove the oil seal.

**NOTICE:**

**Be careful not to damage the front housing.**

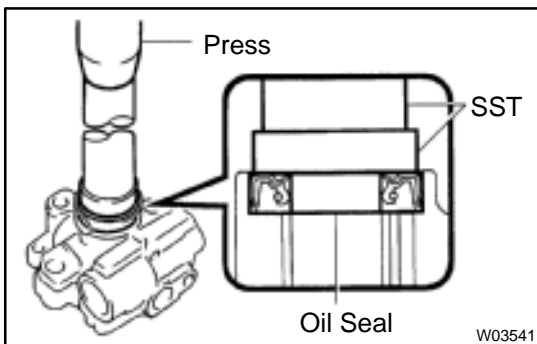

- (b) Coat a new oil seal lip with power steering fluid.

- (c) Using SST, press in the oil seal.

SST 09950-60010 (09951-00330),  
09950-70010 (09951-07100)

**NOTICE:**

**Make sure to install the oil seal facing the correct direction.**

## REASSEMBLY

### NOTICE:

When using a vise, do not overtighten it.

1. **COAT WITH POWER STEERING FLUID**  
(See page [SR-18](#))
2. **INSTALL VANE PUMP SHAFT**
3. **INSTALL STRAIGHT PINS**

Using a plastic hammer, tap in 2 new pins.

### NOTICE:

Be careful not to damage the pins.

4. **INSTALL CAM RING**

Align the holes of the ring and 2 straight pins, and install the ring with the inscribed mark facing outward.

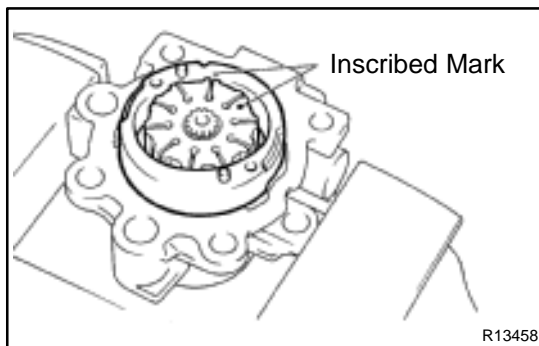

5. **INSTALL VANE PUMP ROTOR**

- (a) Install the rotor with the inscribed mark facing outward.
- (b) Install a new snap ring to the vane pump shaft.

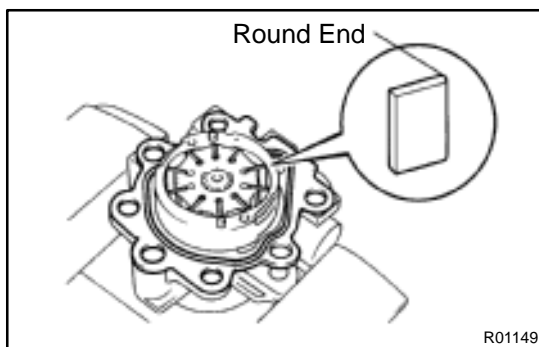

6. **INSTALL VANE PLATES**

Install the 10 plates with the round end facing outward.

7. **INSTALL GASKET**

Install a new gasket.

8. **INSTALL SIDE PLATE**

Align the holes of the plate and 2 straight pins.

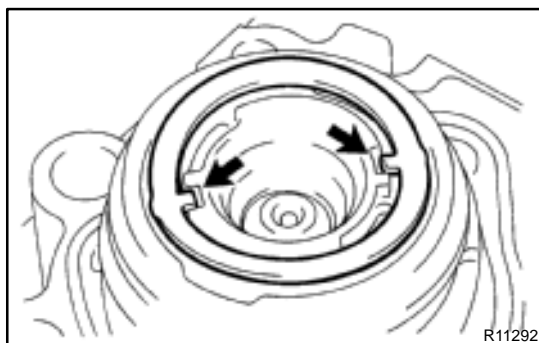

9. **INSTALL WAVE WASHER**

Install the washer so that its protrusions fit into the slots in the side plate.

10. **INSTALL REAR HOUSING**

- (a) Coat 2 new O-rings with power steering fluid and install them to the housing.
- (b) Torque the 4 bolts.

**5S-FE and 1MZ-FE Engines:**

**Torque: 24 N·m (240 kgf-cm, 17 ft-lbf)**

**11. INSTALL SPRING, FLOW CONTROL VALVE AND PRESSURE PORT UNION**

- (a) Install the valve facing the correct direction.  
(See page [SR-18](#))
- (b) Coat a new O-ring with power steering fluid and install it to the union.
- (c) Torque the union.

**5S-FE and 1MZ-FE Engines:****Torque: 83 N·m (850 kgf-cm, 62 ft-lbf)****12. INSTALL SUCTION PORT UNION**

- (a) Coat a new O-ring with power steering fluid and install it to the union.
- (b) Torque the bolt.

**5S-FE and 1MZ-FE Engines:****Torque: 13 N·m (130 kgf-cm, 9 ft-lbf)****13. INSTALL FRONT AND REAR BRACKETS**

Torque the 3 bolts and 2 nuts.

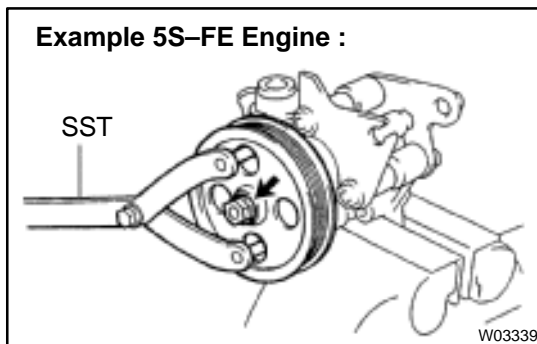
**5S-FE and 1MZ-FE Engines:****Torque: 43 N·m (440 kgf-cm, 32 ft-lbf)****14. INSTALL VANE PUMP PULLEY**

Using SST to stop the pulley rotating, torque the nut.

SST 09960-10010 (09962-01000, 09963-01000)

**5S-FE and 1MZ-FE Engines:****Torque: 43 N·m (440 kgf-cm, 32 ft-lbf)****15. MEASURE PS VANE PUMP ROTATING TORQUE**(See page [SR-22](#))

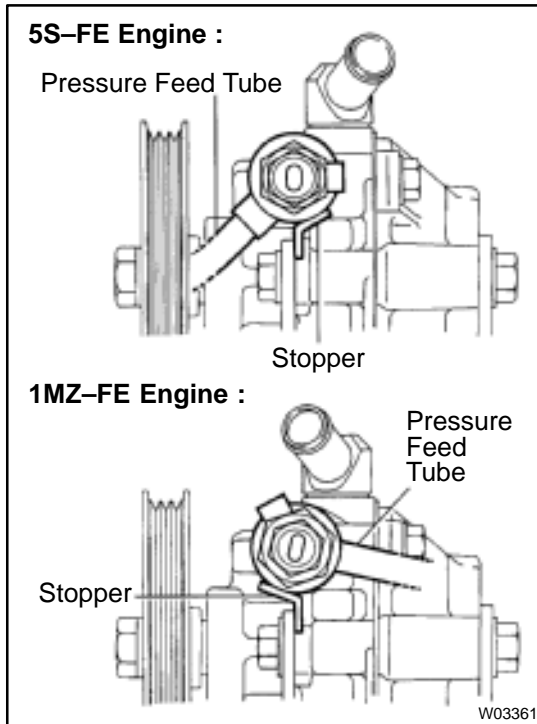

## INSTALLATION

### 1. INSTALL PRESSURE FEED TUBE

- (a) Torque the union bolt with a new gasket.

HINT:

Make sure the stopper of the tube is touching the front bracket, as shown, then torque the union bolt.

**5S-FE and 1MZ-FE Engines:**

**Torque: 52 N·m (525 kgf-cm, 38 ft-lbf)**

- (b) Install the oil pressure switch to the union bolt.

**5S-FE and 1MZ-FE Engines:**

**Torque: 21 N·m (210 kgf-cm, 15 ft-lbf)**

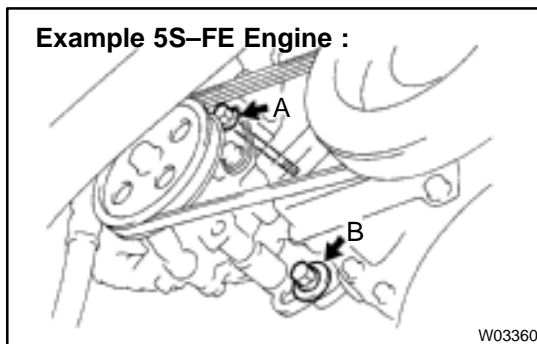

### 2. INSTALL PS VANE PUMP ASSEMBLY WITH PRESS-ER FEED TUBE

Temporarily tighten the 2 (A and B) bolts.

### 3. INSTALL DRIVE BELT

- (a) Adjust drive belt tension.  
(See page [SR-3](#))

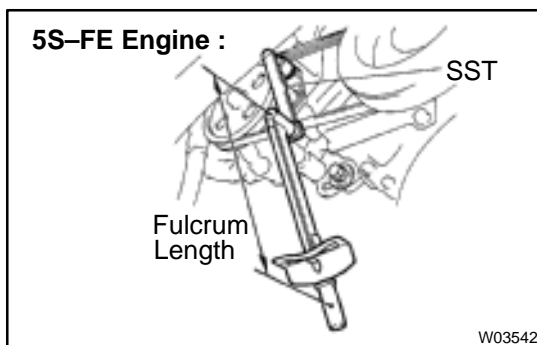

- (b) 5S-FE Engine:  
Using SST, torque the A bolt.  
SST 09249-63010  
**Torque: 29 N·m (293 kgf-cm, 21 ft-lbf)**

HINT:

Use a torque wrench with a fulcrum length of 300 mm (11.81 in.).

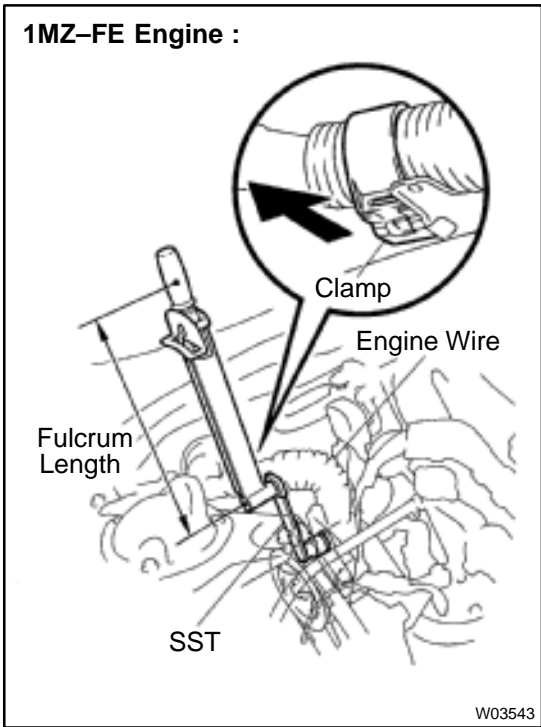

- (c) 1MZ-FE Engine:  
Using SST, torque the A bolt.  
SST 09249-63010  
**Torque: 29 N·m (293 kgf·cm, 21 ft·lbf)**

HINT:

- ★ Use a torque wrench with a fulcrum length of 300 mm (11.81 in.).
  - ★ Disconnect the clamp with engine wire.
- (d) Torque the B bolt.

**5S-FE and 1MZ-FE Engines:  
Torque: 43 N·m (440 kgf·cm, 32 ft·lbf)**

- (e) Connect the connector to the oil pressure switch.

**NOTICE:**

**Be careful for oil on the connector.**

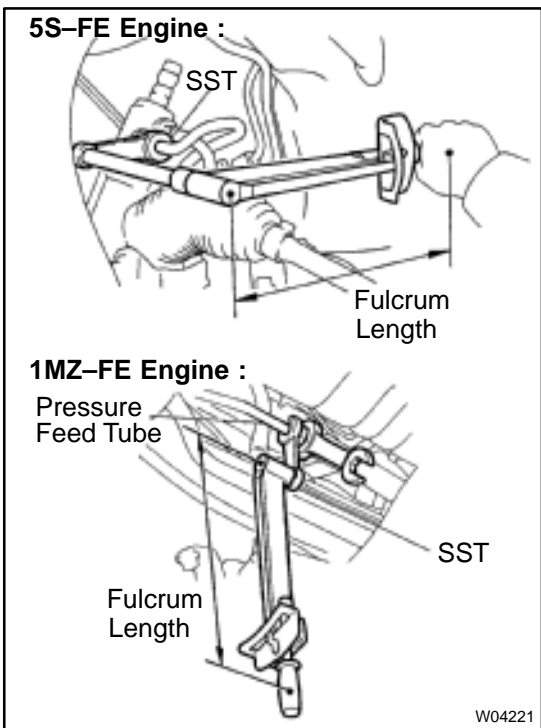

**4. CONNECT PRESSURE FEED TUBE**

- (a) Using SST, connect the tube.  
SST 09631-22020  
**5S-FE Engine:  
Torque: 32 N·m (326 kgf·cm, 24 ft·lbf)**  
**1MZ-FE Engine:  
Torque: 20 N·m (203 kgf·cm, 15 ft·lbf)**

HINT:

- ★ Use a torque wrench with a fulcrum length of 300 mm (11.81 in.).
- ★ This torque value is effective in case that SST is parallel to a torque wrench.

- (b) 5S-FE Engine:  
Install the clamp to the tube.
- (c) 5S-FE Engine:  
Install the 2 clamp plates and 2 holders to the tube.
- (d) 5S-FE Engine:  
Install the clamp plate set bolt.
- (e) 5S-FE Engine:  
Install the clamp plate set nut.  
**Torque: 10 N·m (100 kgf·cm, 7 ft·lbf)**
- (f) 1MZ-FE Engine:  
Install the 2 clamp plates and 2 holders to the tube.
- (g) 1MZ-FE Engine:  
Tighten the bolt.
- (h) 1MZ-FE Engine:  
Install the 2 clamp plate set nuts.

**Torque: 7.8 N·m (80 kgf·cm, 69 in.-lbf)**

**5. CONNECT RETURN HOSE**

**6. INSTALL FRONT FENDER APRON SEAL RH**

Tighten the 2 bolts.

**7. BLEED POWER STEERING SYSTEM**

(See page [SR-4](#))

# POWER STEERING GEAR COMPONENTS

SR08T-01

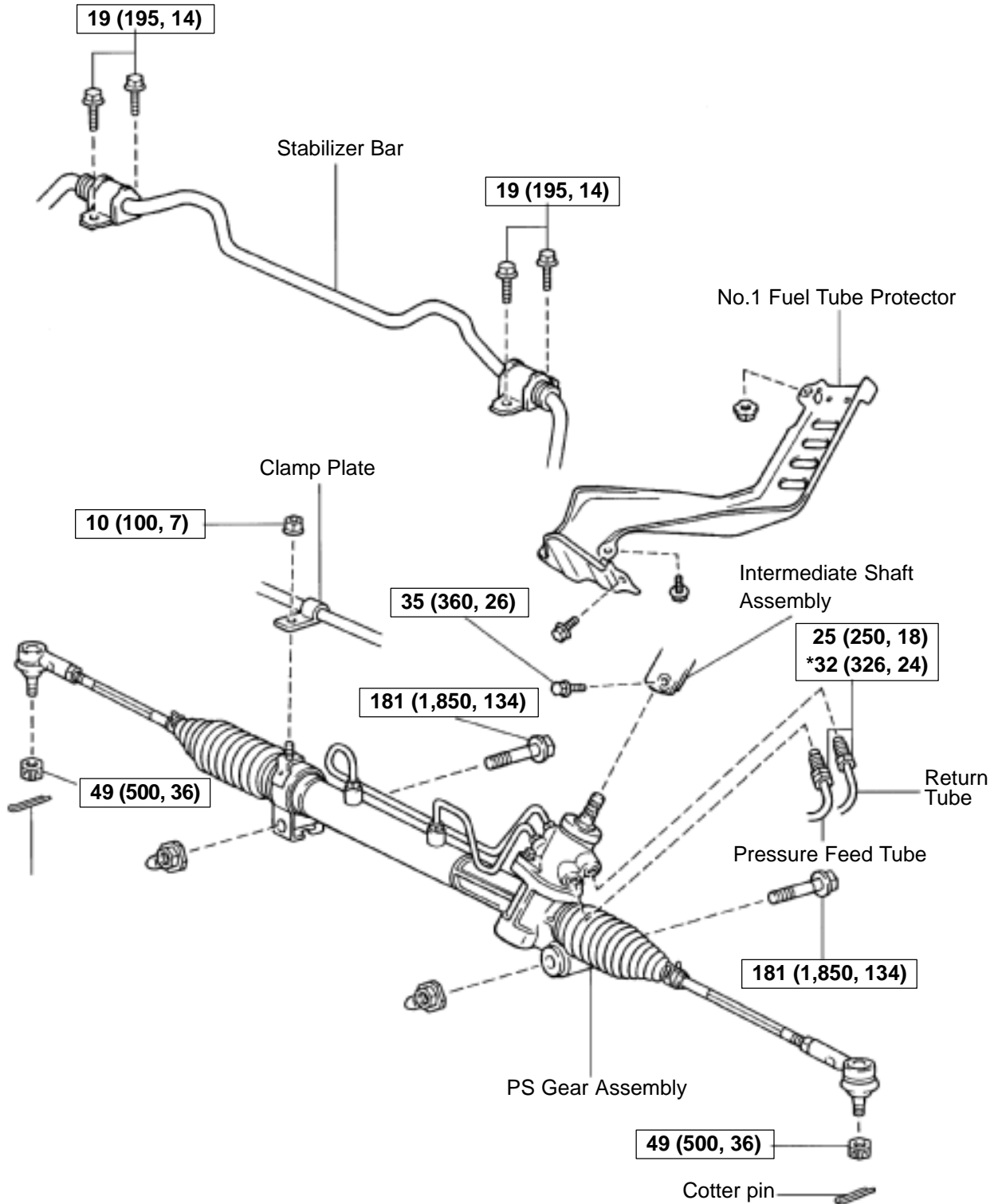

**N·m (kgf·cm, ft·lbf)** : Specified torque  
 Non-reusable part  
 \* For use with SST

W03350

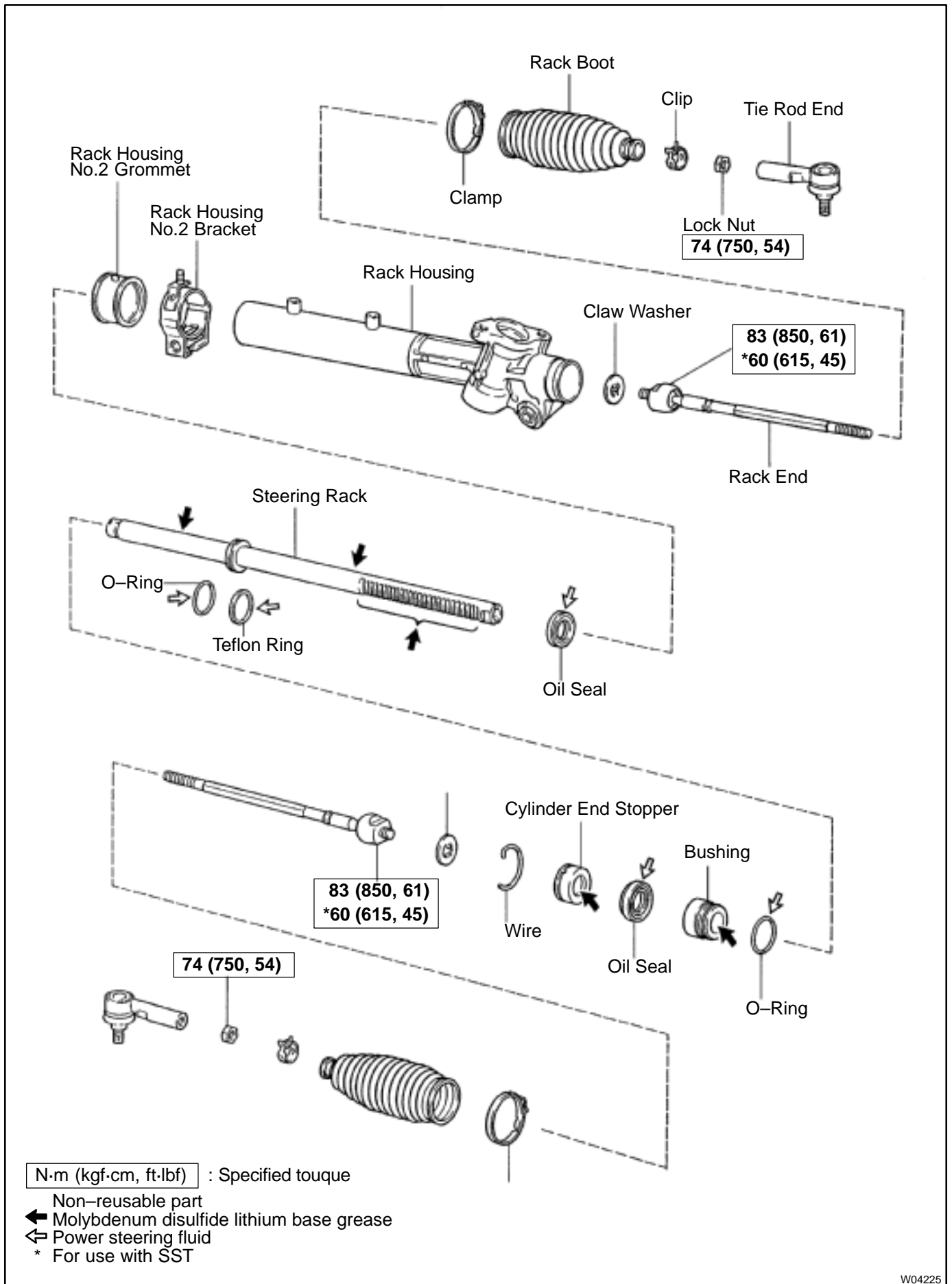



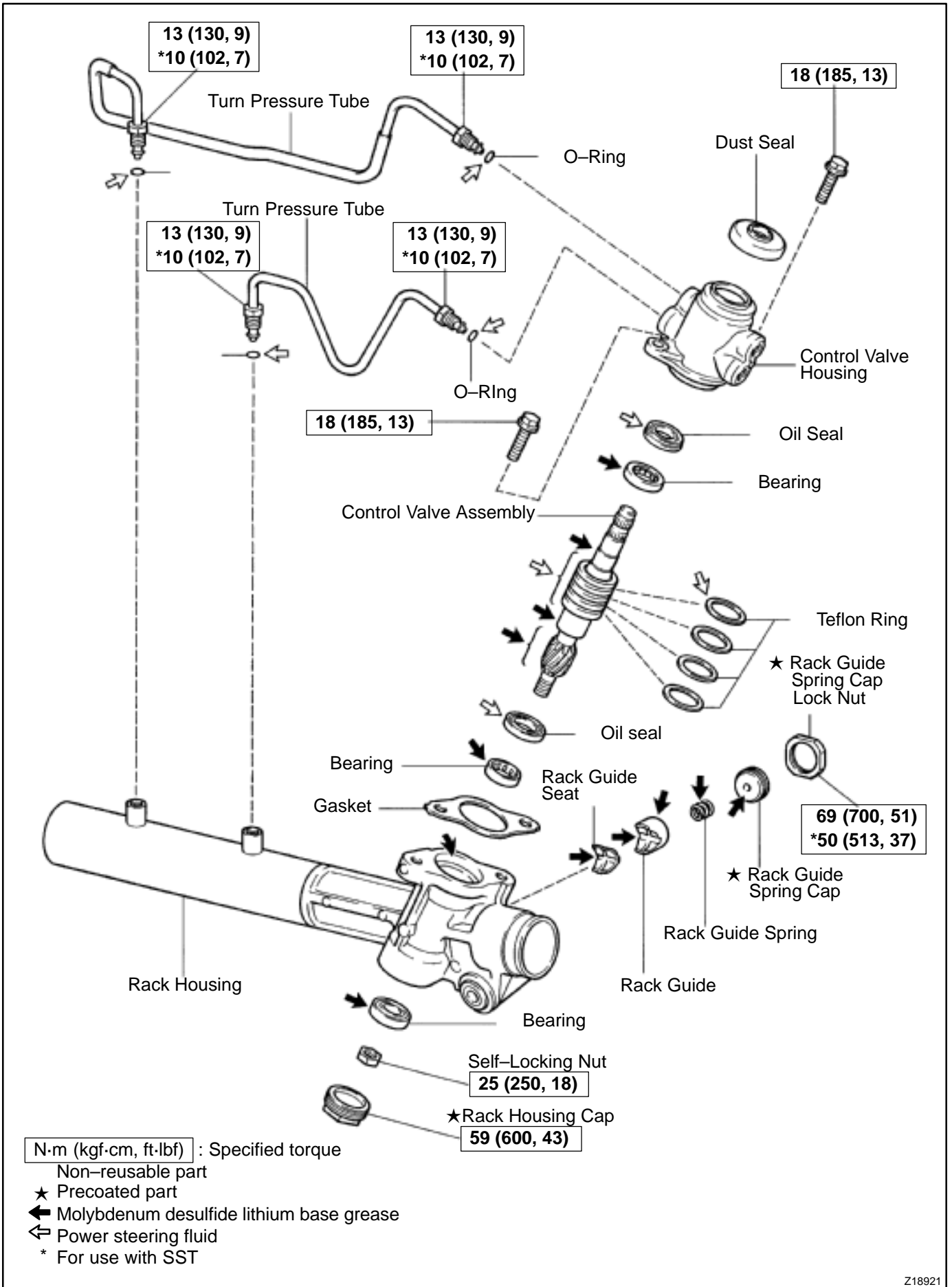

Z18921

## REMOVAL

1. PLACE FRONT WHEELS FACING STRAIGHT AHEAD
2. REMOVE STEERING WHEEL PAD  
(See page SR-11)
3. REMOVE STEERING WHEEL  
(See page SR-11)
4. DISCONNECT RH AND LH TIE ROD ENDS  
(See page SA-10)
5. DISCONNECT INTERMEDIATE SHAFT ASSEMBLY  
(See page SR-11)
6. DISCONNECT CLAMP PLATE

Remove the nut.

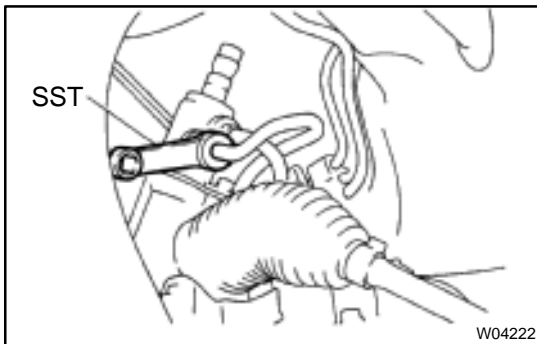

7. DISCONNECT PRESSURE FEED AND RETURN TUBES

Using SST, disconnect the tube.

SST 09631-22020

8. DISCONNECT STABILIZER BAR

Remove the 4 bolts.

HINT:

Do not remove the bar.

9. REMOVE NO.1 FUEL TUBE PROTECTOR

Remove the 2 bolts and nut.

10. REMOVE PS GEAR ASSEMBLY

(a) Remove the 2 gear assembly set bolts and nuts.

HINT:

Lift up the stabilizer bar and remove the bolts.

(b) Remove the gear assembly from the LH of the vehicle.

**NOTICE:**

**Do not damage the turn pressure tubes.**

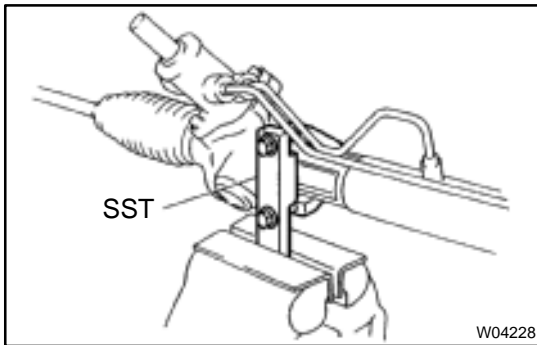

## DISASSEMBLY

### NOTICE:

When using a vise, do not overtighten it.

#### 1. SECURE PS GEAR ASSEMBLY IN VISE

Using SST, secure the gear assembly in a vise.

SST 09612-00012

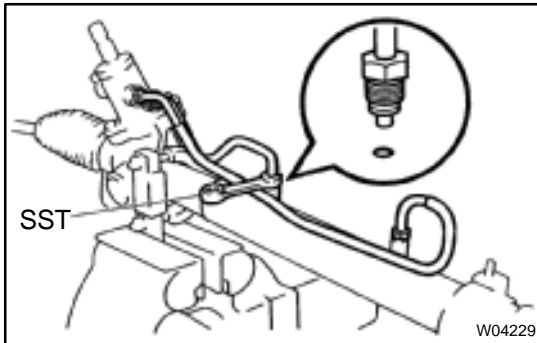

#### 2. REMOVE 2 TURN PRESSURE TUBES

(a) Using SST, remove the tube.

SST 09633-00020

(b) Remove the 2 O-rings from the tube.

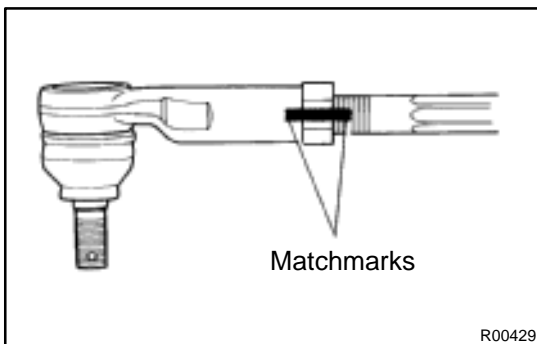

#### 3. REMOVE RH AND LH TIE ROD ENDS AND LOCK NUTS

(a) Place matchmarks on the tie rod end and rack end.

(b) Loosen the lock nut.

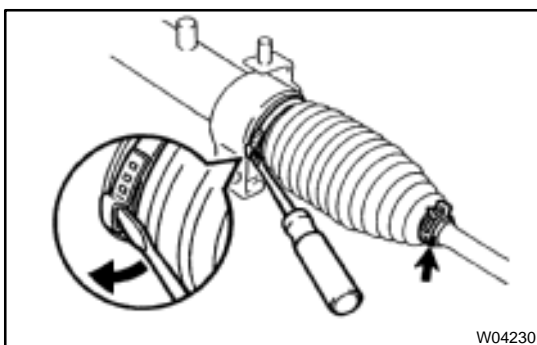

#### 4. REMOVE RH AND LH CLIPS, RACK BOOTS AND CLAMPS

Using a screwdriver, loosen the clamp.

### NOTICE:

- ★ Be careful not to damage the boot.
- ★ Mark the RH and LH boots.

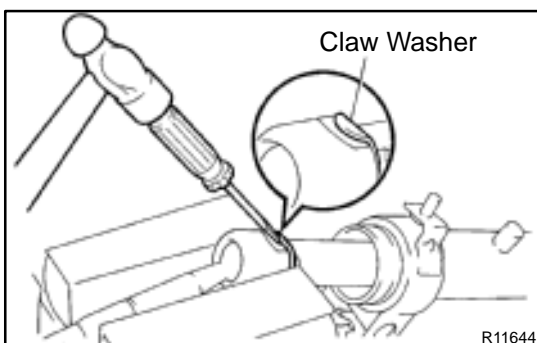

#### 5. REMOVE RH AND LH RACK ENDS AND CLAW WASHERS

(a) Using a screwdriver and hammer, stake back the washer.

### NOTICE:

Avoid any impact to the steering rack.

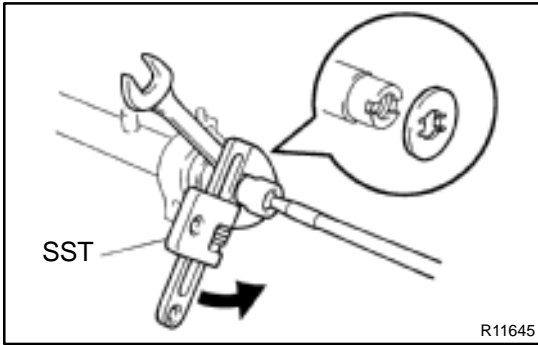

- (b) Using a spanner (24 mm) to hold the steering rack steady, and using SST, remove the rack end.  
SST 09922-10010

**NOTICE:**

- ★ Use SST 09922-10010 in the direction shown in the illustration.
  - ★ Mark the RH and LH rack ends.
- (c) Remove the washer from the rack end.

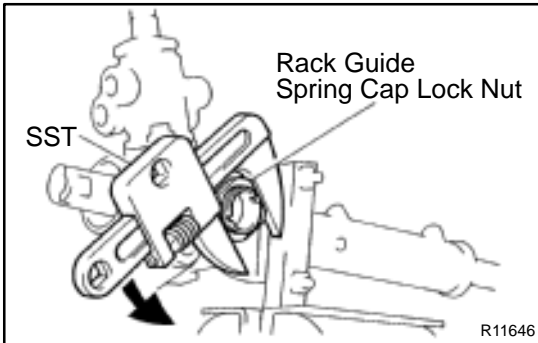

**6. REMOVE RACK GUIDE SPRING CAP LOCK NUT**

- Using SST, remove the nut.  
SST 09922-10010

**NOTICE:**

- Use SST 09922-10010 in the direction shown in the illustration.

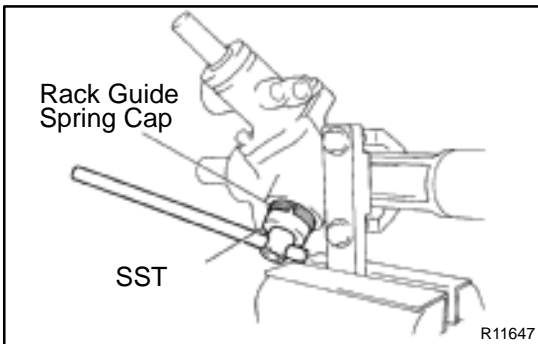

**7. REMOVE RACK GUIDE SPRING CAP, RACK GUIDE SPRING, RACK GUIDE AND RACK GUIDE SEAT**

- (a) Using SST, remove the cap.  
SST 09631-10021
- (b) Remove the seat from the guide.
- 8. REMOVE RACK HOUSING CAP**

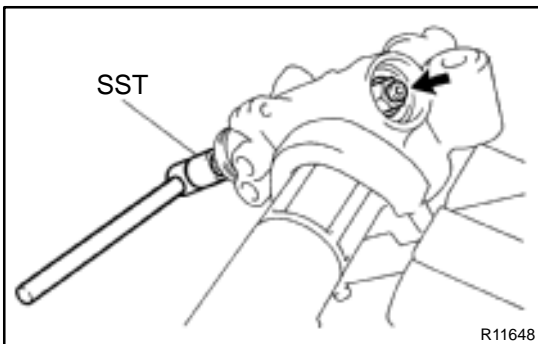

**9. REMOVE SELF-LOCKING NUT**

- Using SST to stop the control valve shaft rotating, remove the nut.  
SST 09616-00010

**10. REMOVE DUST COVER**

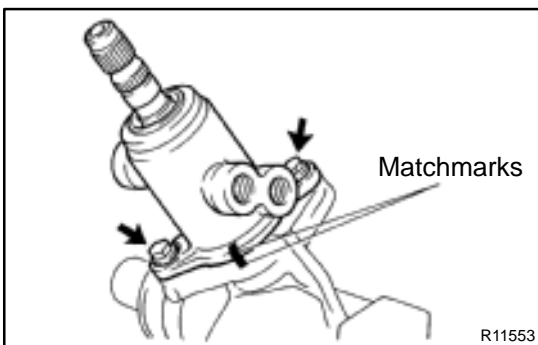

**11. REMOVE CONTROL VALVE HOUSING WITH CONTROL VALVE ASSEMBLY**

- (a) Place matchmarks on the valve housing and rack housing.
- (b) Remove the 2 bolts.
- (c) Remove the gasket from the rack housing.

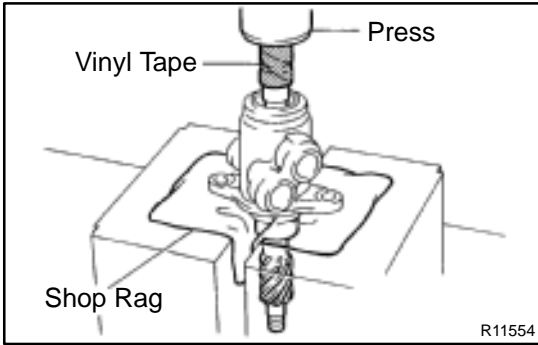

**12. REMOVE CONTROL VALVE ASSEMBLY**

- (a) To prevent oil seal lip damage, wind vinyl tape on the serrated part of the valve shaft.
- (b) Press out the valve assembly with the oil seal.

**NOTICE:**

- ★ Place a shop rag between the valve housing and the blocks.
- ★ Be careful not to drop the valve assembly.
- ★ Be careful not to damage the oil seal lip.

**13. REMOVE OIL SEAL**

Remove the oil seal from the control valve assembly.

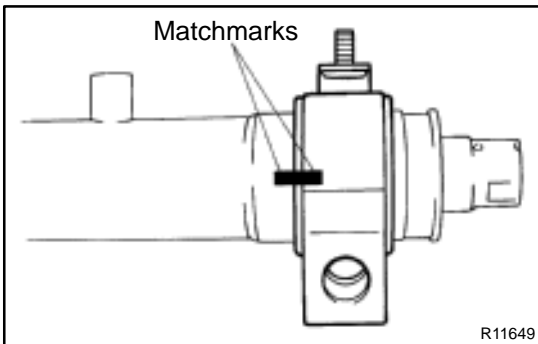

**14. REMOVE RACK HOUSING NO.2 BRACKET AND GROMMET**

- (a) Place matchmarks on the bracket and rack housing.

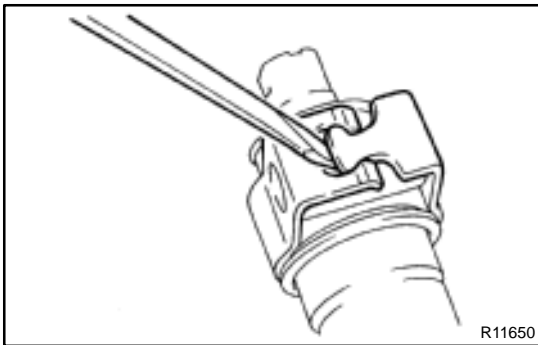

- (b) Using a screwdriver, pry the clamp of the bracket.
- (c) Remove the grommet from the bracket.

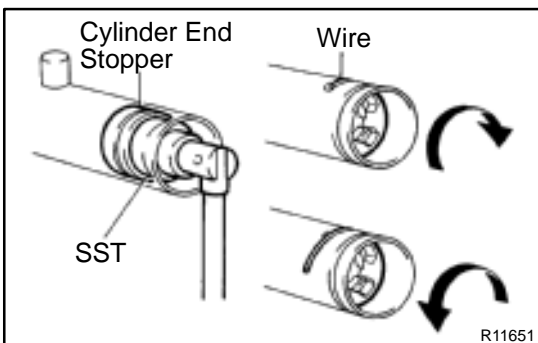

**15. REMOVE CYLINDER END STOPPER**

- (a) Using SST, turn the stopper clockwise until the wire end is visible through the service hole.  
SST 09631-10021
- (b) Using SST, turn the stopper counterclockwise, and remove the wire.  
SST 09631-10021

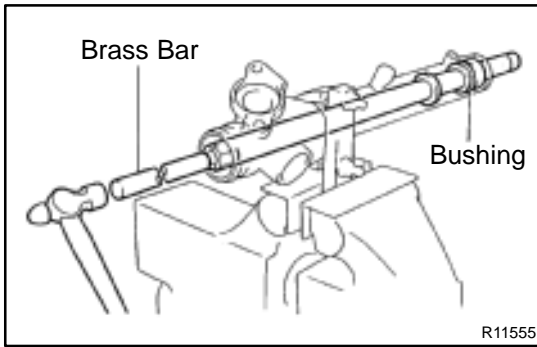
**16. REMOVE STEERING RACK AND BUSHING**

- (a) Using a brass bar and hammer, tap out the rack with the bushing.
- (b) Remove the bushing from the rack.
- (c) Remove the O-ring from the bushing.

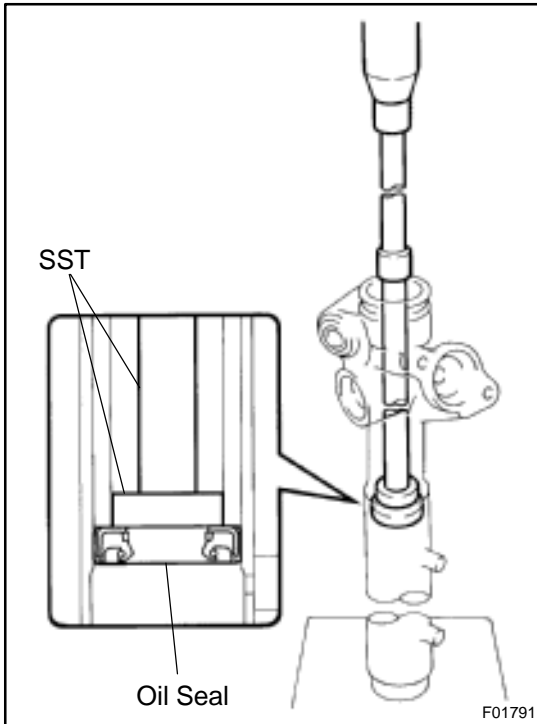
**17. REMOVE OIL SEAL**

Using SST, press out the oil seal.

SST 09950-60010 (09951-00290),  
09950-70010 (09951-07360)

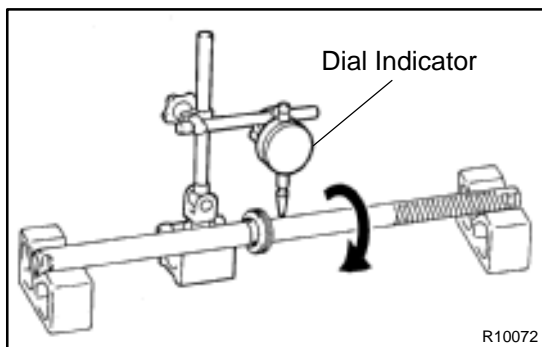

## INSPECTION

### NOTICE:

When using a vise, do not overtighten it.

#### 1. INSPECT STEERING RACK

- (a) Using a dial indicator, check the rack for runout and for teeth wear and damage.

**Maximum runout: 0.03 mm (0.0118 in.)**

- (b) Check the back surface for wear and damage.

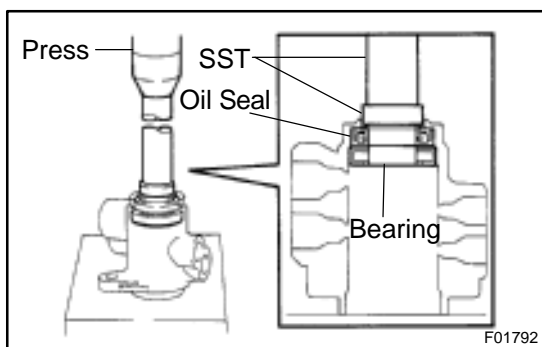

#### 2. IF NECESSARY, REPLACE OIL SEAL AND BEARING

- (a) Using SST, press out the oil seal and bearing from the control valve housing.

SST 09950-60010 (09951-00250),  
09950-70010 (09951-07200)

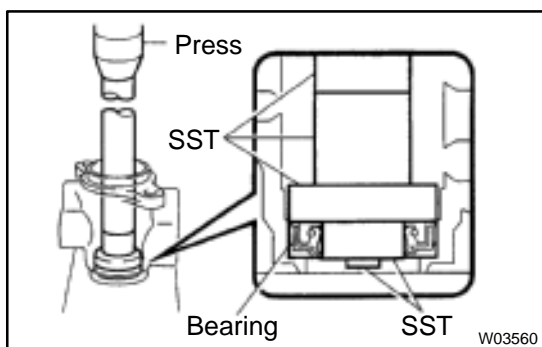

- (b) Coat a new oil seal lip with power steering fluid.

- (c) Using SST, press in the oil seal.

SST 09950-60010 (09951-00180, 09951-00320,  
09952-06010), 09950-70010 (09951-07200)

### NOTICE:

**Make sure to install the oil seal facing the correct direction.**

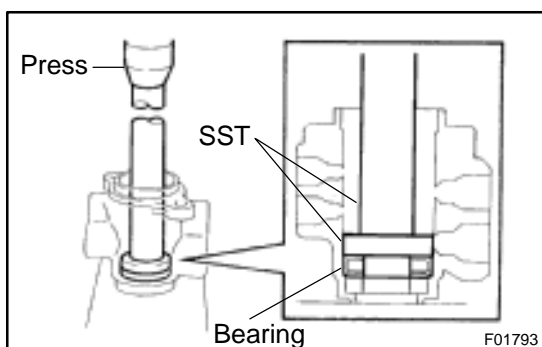

- (d) Coat a new bearing with molybdenum disulfide lithium base grease.

- (e) Using SST, press in the bearing.

SST 09950-60010 (09951-00340),  
09950-70010 (09951-07200)

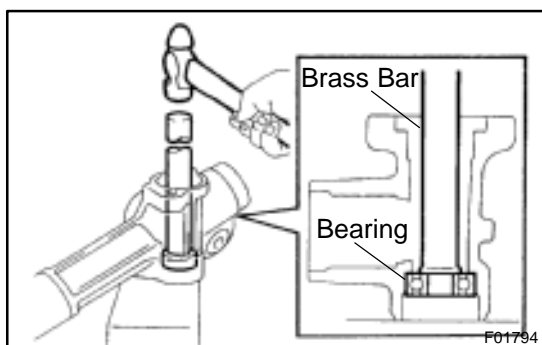

#### 3. IF NECESSARY, REPLACE 2 BEARINGS

- (a) Using a brass bar and hammer, tap out the bearing from the rack housing.

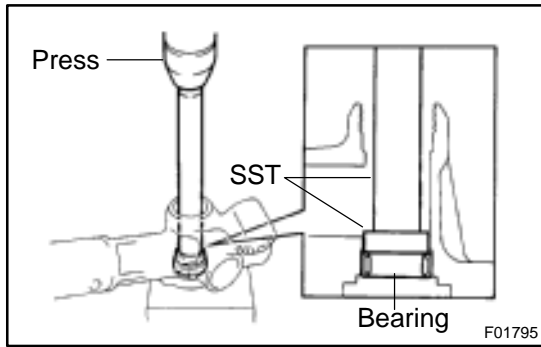

- (b) Using SST, press out the bearing from the rack housing.  
SST 09950-60010 (09951-00260),  
09950-70010 (09951-07200)

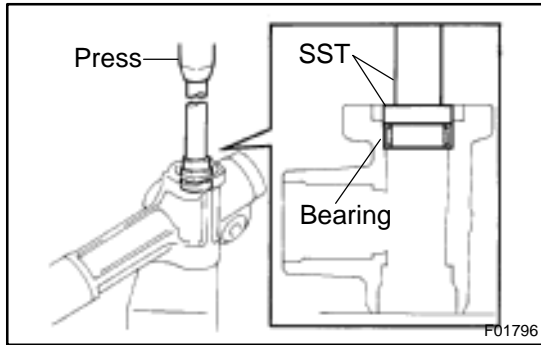

- (c) Coat a new bearing with molybdenum disulfide lithium base grease.
- (d) Using SST, press in the bearing.  
SST 09950-60010 (09951-00310),  
09950-70010 (09951-07200)

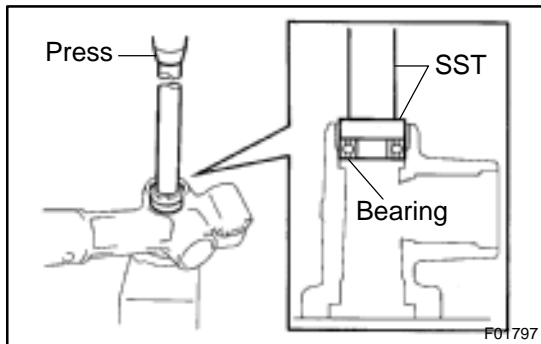

- (e) Coat a new bearing with molybdenum disulfide lithium base grease.
- (f) Using SST, press in the bearing.  
SST 09950-60010 (09951-00320),  
09950-70010 (09951-07200)

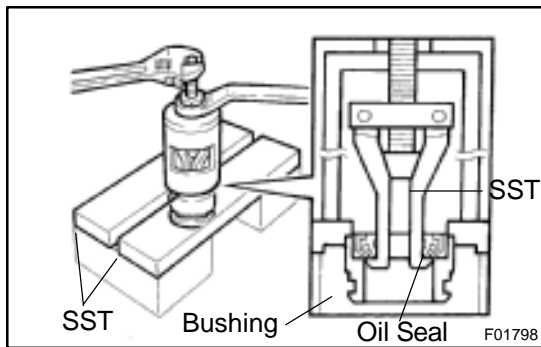

**4. IF NECESSARY, REPLACE OIL SEAL**

- (a) Using SST, remove the oil seal from the bushing.  
SST 09527-20011, 09612-24014 (09613-22011)

**NOTICE:**

**Be careful not to damage the bushing.**

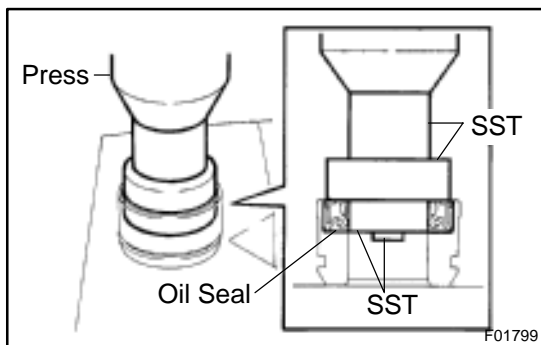

- (b) Coat a new oil seal lip with power steering fluid.
- (c) Using SST, press in the oil seal.  
SST 09950-60010 (09951-00240, 09951-00400,  
09952-06010)

**NOTICE:**

**Make sure to install the oil seal facing the correct direction.**



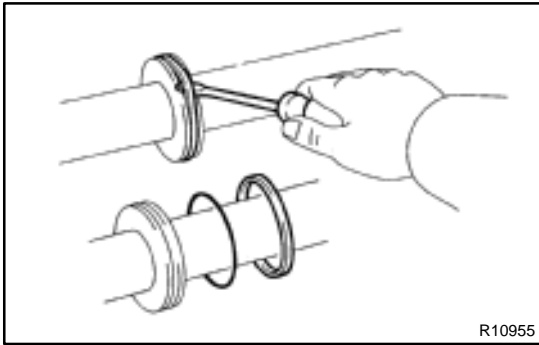

**5. IF NECESSARY, REPLACE TEFLON RING AND O-RING**

- (a) Using a screwdriver, remove the teflon ring and O-ring from the steering rack.

**NOTICE:**

**Be careful not to damage the groove for the teflon ring.**

- (b) Coat a new O-ring with power steering fluid and install it.

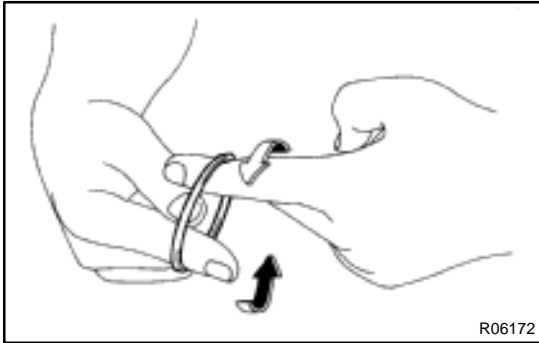

- (c) Expand a new teflon ring with your fingers.

**NOTICE:**

**Be careful not to over-expand the ring.**

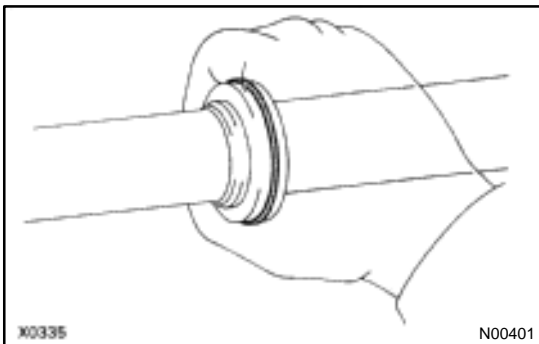

- (d) Coat the ring with power steering fluid.
- (e) Install the ring to the steering rack, and settle it down with your fingers.

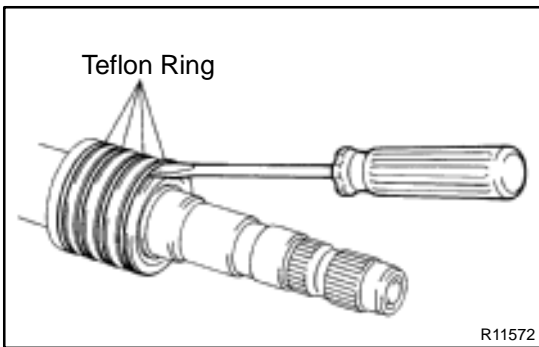

**6. IF NECESSARY, REPLACE TEFLON RINGS**

- (a) Using a screwdriver, remove the 4 rings from the control valve assembly.

**NOTICE:**

**Be careful not to damage the grooves for the teflon ring.**

- (b) Expand 4 new teflon rings with your fingers.

**NOTICE:**

**Be careful not to over-expand the teflon ring.**

- (c) Coat the rings with power steering fluid.
- (d) Install the rings to the control valve assembly, and settle them down with your fingers.

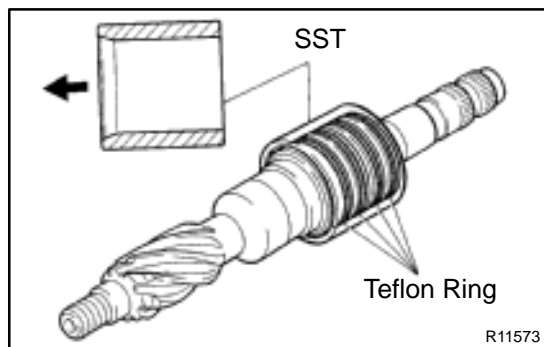

- (e) Carefully slide the tapered end of SST over the rings until the rings fit to the steering rack.  
SST 09631-20081

**NOTICE:**

**Be careful not to damage the rings.**

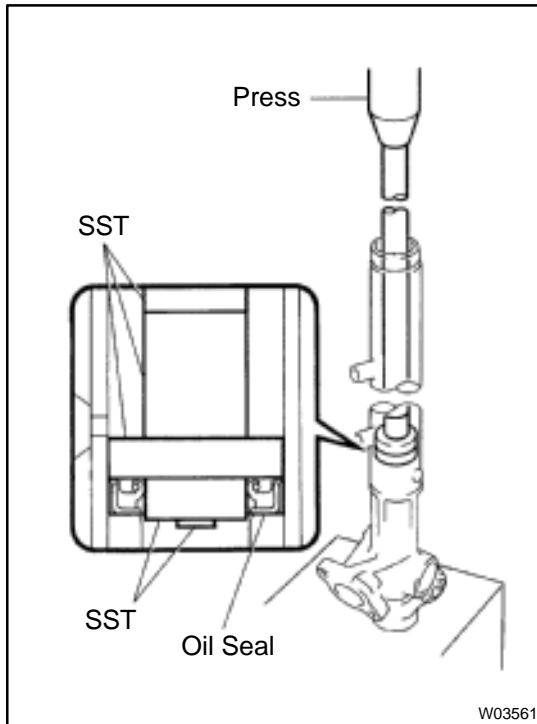

## REASSEMBLY

### NOTICE:

When using a vise, do not overtighten it.

1. **COAT WITH POWER STEERING FLUID OR MOLYBDENUM DISULFIDE LITHIUM BASE GREASE**  
(See pages SR-31)
2. **INSTALL OIL SEAL**
  - (a) Coat a new oil seal lip with power steering fluid.
  - (b) Using SST, press in the oil seal.  
SST 09950-60010 (09951-00240, 09951-00430, 09952-06010), 09950-70010 (09951-07360)

### NOTICE:

- ★ **Make sure to install the oil seal facing the correct direction.**
- ★ **Take care that the oil seal does not get reversed as you install it.**

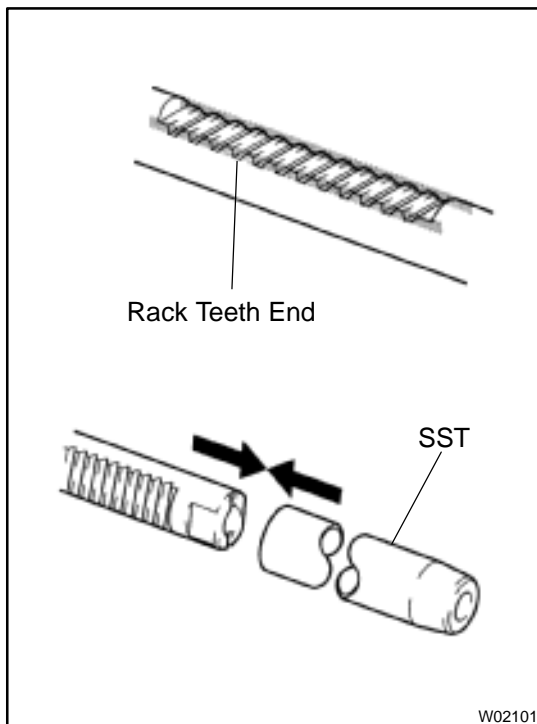

### 3. INSTALL STEERING RACK

- (a) Install SST to the rack.  
SST 09631-33010

#### HINT:

If necessary, scrape the burrs off the rack teeth end and bur-nish.

- (b) Coat the SST with power steering fluid.
- (c) Install the rack into the rack housing.

### NOTICE:

**Be careful not to damage the oil seal lip.**

- (d) Remove SST.

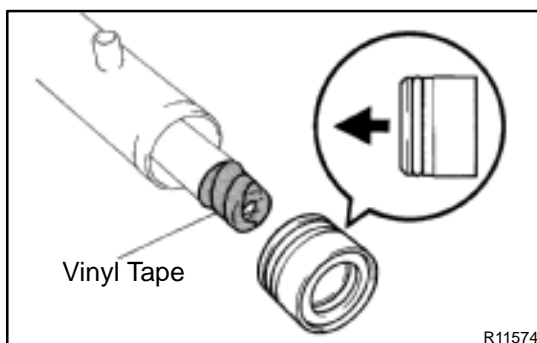

### 4. INSTALL BUSHING

- (a) Coat a new O-ring with power steering fluid and install it to the bushing.
- (b) To prevent oil seal lip damage, wind vinyl tape on the steering rack end, and apply power steering fluid.
- (c) Install the bushing.

### NOTICE:

- ★ **Make sure to install the bushing facing the correct direction.**
- ★ **Be careful not to damage the oil seal lip.**

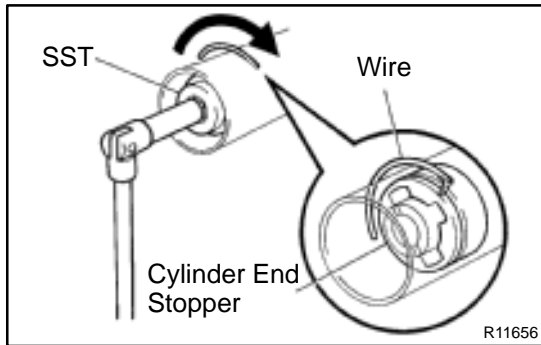

### 5. INSTALL CYLINDER END STOPPER

- (a) Align the installation hole for the wire of the stopper with the slot of the rack housing.
- (b) Install a new wire into the stopper.
- (c) Using SST, turn the stopper clockwise  $450 \pm 50^\circ$ .  
SST 09631-10021

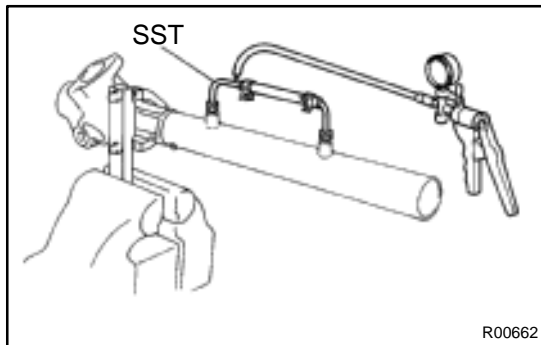

### 6. AIR TIGHTNESS TEST

- (a) Install SST to the rack housing.  
SST 09631-12071
- (b) Apply 53 kPa (400 mmHg, 15.75 in.Hg) of vacuum for about 30 seconds.
- (c) Check that there is no change in the vacuum.  
If there is change in the vacuum, check the installation of the oil seals.

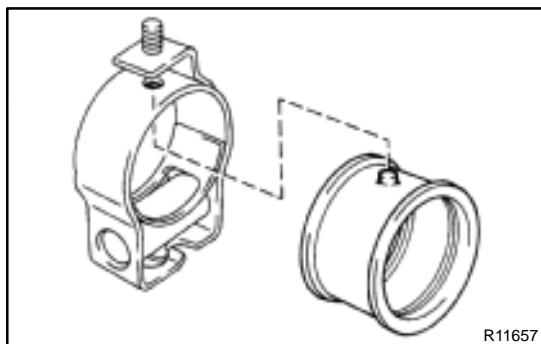

### 7. INSTALL RACK HOUSING NO.2 BRACKET AND GROMMET

- (a) Install the grommet to the bracket.  
HINT:  
Align the projection of the grommet with the hole of the bracket.
- (b) Align the matchmarks on the bracket and rack housing.

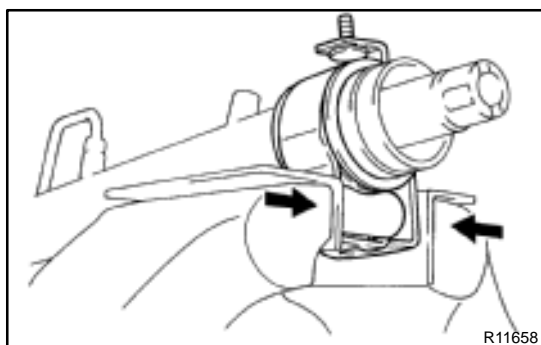

- (c) Place the bracket in a vise and tighten the vise to fasten the clamp.

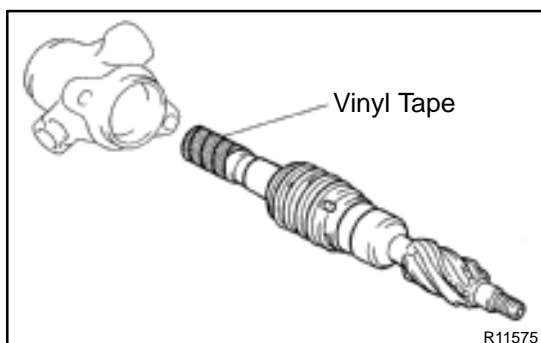

### 8. INSTALL CONTROL VALVE ASSEMBLY

- (a) To prevent oil seal lip damage, wind vinyl tape on the serrated part of the valve shaft.
- (b) Coat the teflon rings with power steering fluid.
- (c) Install the valve assembly into the valve housing.

#### NOTICE:

**Be careful not to damage the teflon rings and oil seal.**

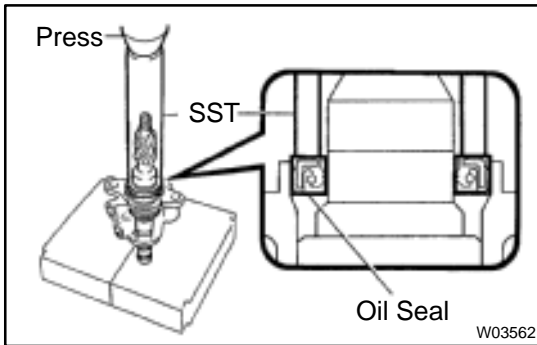
**9. INSTALL OIL SEAL**

- (a) Coat a new oil seal lip with power steering fluid.
- (b) Using SST, press in the oil seal.  
SST 09612-22011

**NOTICE:**

**Make sure to install the oil seal facing the correct direction.**

**10. INSTALL CONTROL VALVE HOUSING WITH CONTROL VALVE ASSEMBLY**

- (a) Place a new gasket on the rack housing.
- (b) Align the matchmarks on the valve housing and rack housing.
- (c) Torque the 2 bolts.

**Torque: 18 N·m (185 kgf·cm, 13 ft·lbf)**

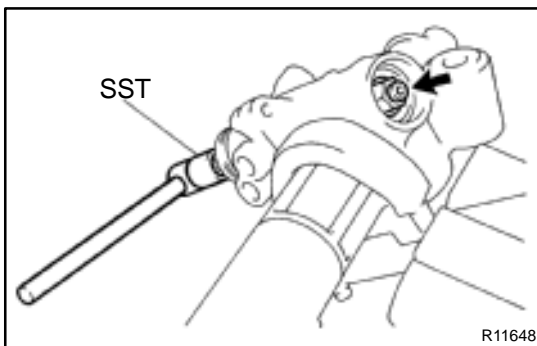
**11. INSTALL SELF-LOCKING NUT**

Using SST to stop the control valve shaft rotating, torque a new nut.

SST 09616-00010

**Torque: 25 N·m (250 kgf·cm, 18 ft·lbf)**

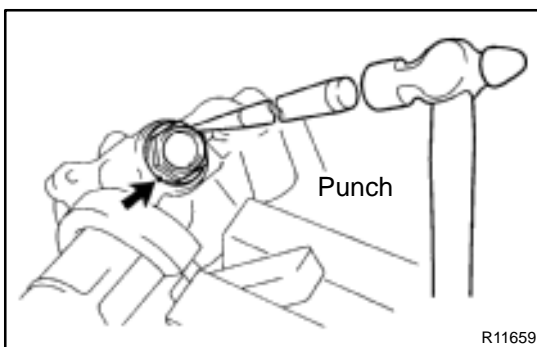
**12. INSTALL DUST COVER****13. INSTALL RACK HOUSING CAP**

- (a) Apply sealant to 2 or 3 threads of the cap.

**Sealant:**

**Part No.08833-00080, THREE BOND 1344, LOCTITE 242 or equivalent**

- (b) Torque the cap.

**Torque: 59 N·m (600 kgf·cm, 43 ft·lbf)**

- (c) Using a punch and hammer, stake the 2 parts of the cap.

**14. INSTALL RACK GUIDE SEAT, RACK GUIDE, RACK GUIDE SPRING AND RACK GUIDE SPRING CAP**

- (a) Install the seat to the guide.
- (b) Apply sealant to 2 or 3 threads of the cap.

**Sealant:**

**Part No.08833-00080, THREE BOND 1344, LOCTITE 242 or equivalent**

- (c) Temporarily install the cap.

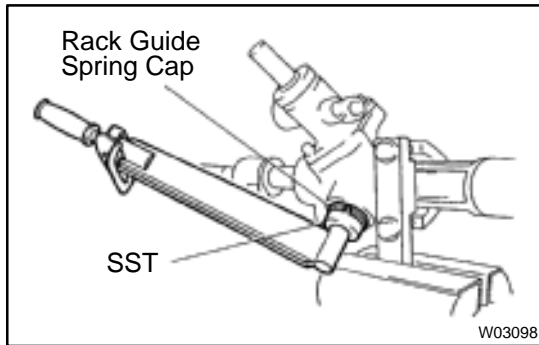
**15. ADJUST TOTAL PRELOAD**

- (a) To prevent the steering rack teeth from damaging the oil seal lip, temporarily install the RH and LH rack ends.
- (b) Using SST, torque the rack guide spring cap.  
SST 09631-10021  
**Torque: 25 N·m (250 kgf·cm, 18 ft·lbf)**

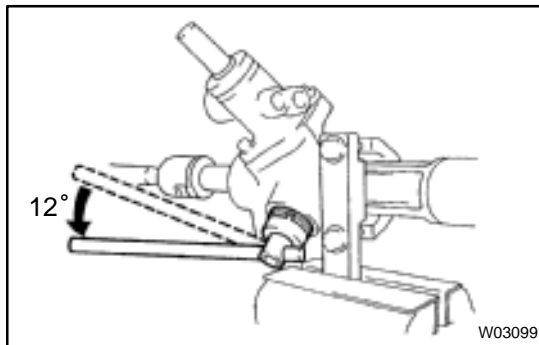

- (c) Using SST, return the cap 12°.  
SST 09631-10021

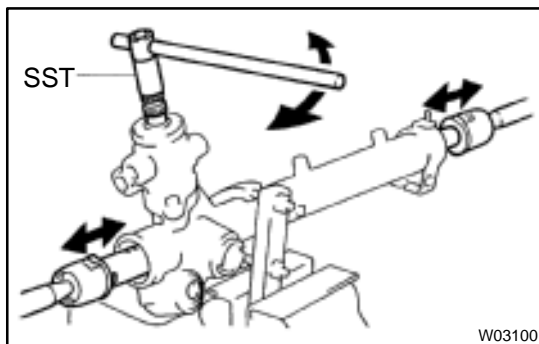

- (d) Using SST, turn the control valve shaft right and left 1 or 2 times.  
SST 09616-00010
- (e) Using SST, loosen the cap until the rack guide spring is not functioning.  
SST 09631-10021

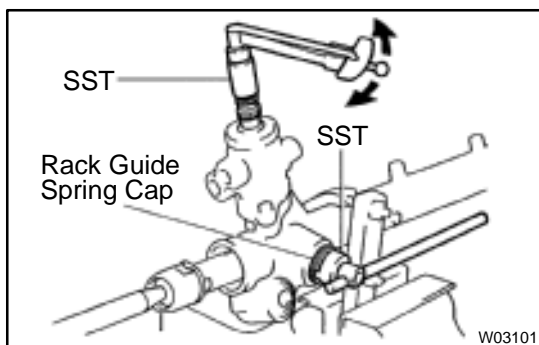

- (f) Using SST and a torque wrench, tighten the cap until the preload is within specification.  
SST 09616-00010, 09631-10021  
**Preload (turning):  
0.8 – 1.4 N·m (8 – 14 kgf·cm, 6.9 – 12.2 in·lbf)**

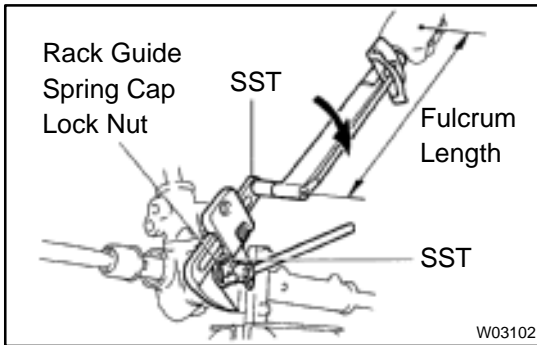
**16. INSTALL RACK GUIDE SPRING CAP LOCK NUT**

- (a) Apply sealant to 2 or 3 threads of the nut.

**Sealant:**

**Part No.08833-00080, THREE BOND 1344, LOCTITE 242 or equivalent**

- (b) Using SST to hold the rack guide spring cap, and using SST, torque the nut.

SST 09631-10021, 09922-10010

**Torque: 50 N·m (513 kgf·cm, 37 ft·lbf)**

**NOTICE:**

**Use SST 09922-10010 in the direction shown in the illustration.**

**HINT:**

Use a torque wrench with a fulcrum length of 345 mm (13.58 in.).

- (c) Recheck the total preload.

**Preload (turning):**

**0.8 – 1.4 N·m (8 – 14 kgf·cm, 6.9 – 12.2 in.-lbf)**

- (d) Remove the RH and LH rack ends.

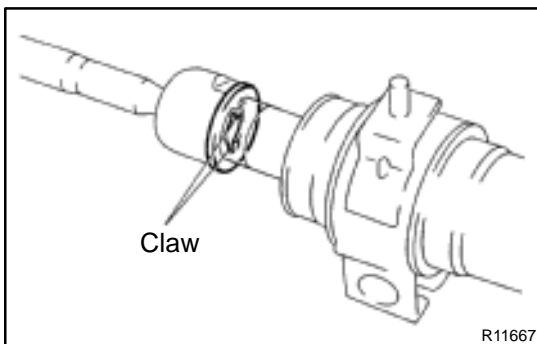
**17. INSTALL RH AND LH CLAW WASHERS AND RACK ENDS**

- (a) Install a new claw washer, and temporarily install the rack end.

**HINT:**

Align the claws of the washer with the steering rack grooves.

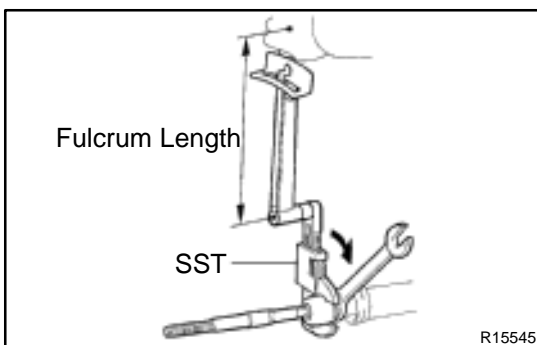

- (b) Using a spanner (24 mm) to hold the steering rack steady, and using SST, torque the rack end.

SST 09922-10010

**Torque: 60 N·m (615 kgf·cm, 45 ft·lbf)**

**NOTICE:**

**Use SST 09922-10010 in the direction shown in the illustration.**

**HINT:**

Use a torque wrench with a fulcrum length of 345 mm (13.58 in.).

- (c) Using a brass bar and hammer, stake the washer.

**NOTICE:**

**Avoid any impact to the rack.**

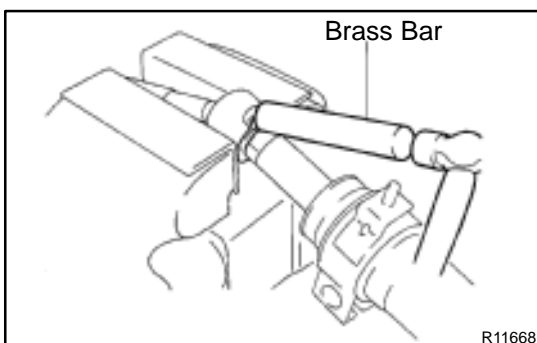

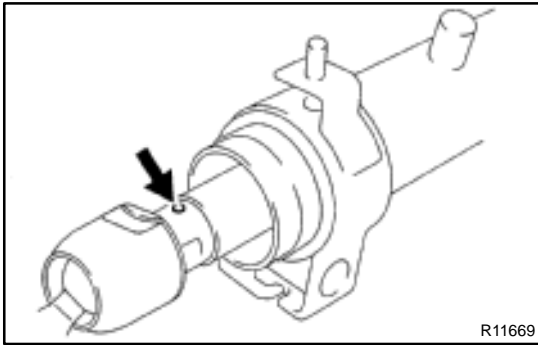

### 18. INSTALL RH AND LH RACK BOOTS, CLAMPS AND CLIPS

- (a) Ensure that the steering rack hole is not clogged with grease.

**HINT:**

If the hole is clogged, the pressure inside the boot will change after it is assembled and the steering wheel is turned.

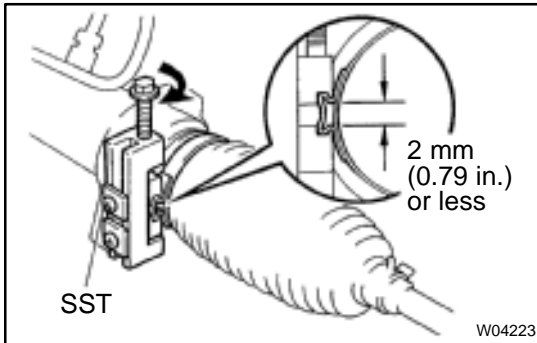

- (b) Install the boot.

**NOTICE:**

**Be careful not to damage or twist the boot.**

- (c) Using SST, tighten the clamp as shown in the illustration.  
SST 09521-24010

### 19. INSTALL RH AND LH TIE ROD ENDS AND LOCK NUTS

- (a) Screw the lock nut and tie rod end onto the rack end until the matchmarks are aligned.

- (b) After adjusting toe-in, torque the nut.

(See page [SA-4](#))

**Torque: 74 N·m (750 kgf·cm, 54 ft·lbf)**

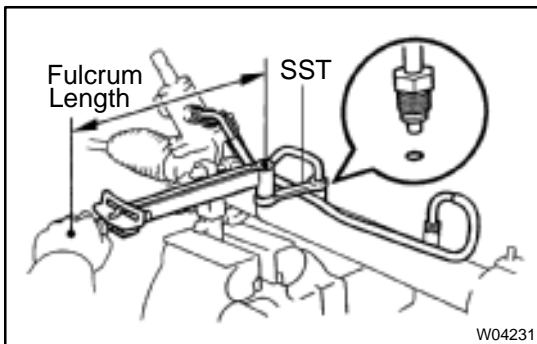

### 20. INSTALL 2 TURN PRESSURE TUBES

- (a) Coat 2 new O-rings with power steering fluid and install them to the tube.

- (b) Using SST, install the tube.

SST 09633-00020

**Torque: 10 N·m (102 kgf·cm, 7 ft·lbf)**

**HINT:**

- ★ Use a torque wrench with a fulcrum length of 250 mm (9.84 in.).
- ★ This torque value is effective in case that SST is parallel to a torque wrench.



## INSTALLATION

### 1. INSTALL PS GEAR ASSEMBLY

- (a) Install the gear assembly from the LH of the vehicle.

#### NOTICE:

**Do not damage the turn pressure tubes.**

- (b) Torque the 2 gear assembly set bolts and nuts.

**Torque: 181 N·m (1,850 kgf·cm, 134 ft·lbf)**

#### HINT:

Lift up the stabilizer bar and install the bolts.

### 2. INSTALL NO.1 FUEL TUBE PROTECTOR

Install the 2 bolts and nut.

### 3. CONNECT STABILIZER BAR

Torque the 4 bolts.

**Torque: 19 N·m (195 kgf·cm, 14 ft·lbf)**

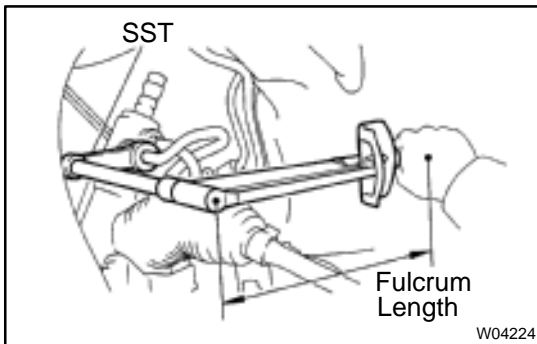

### 4. CONNECT PRESSURE FEED AND RETURN TUBES

Using SST, connect the tube.

SST 09631-22020

**Torque: 32 N·m (326 kgf·cm, 24 ft·lbf)**

#### HINT:

- ★ Use a torque wrench with a fulcrum length of 300 mm (11.81 in.).
- ★ This torque value is effective in case that SST is parallel to a torque wrench.

### 5. CONNECT CLAMP PLATE

Torque the nut.

**Torque: 10 N·m (100 kgf·cm, 7 ft·lbf)**

### 6. CONNECT INTERMEDIATE SHAFT ASSEMBLY

(See page [SR-16](#))

### 7. CONNECT RH AND LH TIE ROD ENDS

(See page [SA-10](#))

### 8. POSITION FRONT WHEELS FACING STRAIGHT AHEAD

#### HINT:

Do it with the front of the vehicle jacked up.

### 9. CENTER SPIRAL CABLE

(See page [SR-16](#))

### 10. INSTALL STEERING WHEEL

- (a) Install the wheel at straight-ahead position.  
 (b) Temporarily tighten the wheel set nut.  
 (c) Connect the connector.

### 11. BLEED POWER STEERING SYSTEM

(See page [SR-4](#))

### 12. CHECK STEERING WHEEL CENTER POINT

13. TORQUE STEERING WHEEL SET NUT  
Torque: 35 N·m (360 kgf·cm, 26 ft·lbf)
14. INSTALL STEERING WHEEL PAD  
(See page [SR-16](#))
15. CHECK FRONT WHEEL ALIGNMENT  
(See page [SA-4](#))